

Sluisstraat 7

P.O. Box 47

NL-7490 AA Delden

The Netherlands

Tel.: +31 74 3770000

Fax: +31 74 3761175

Internet: [www.bredel.com](http://www.bredel.com)E-mail: [hosepumps@bredel.com](mailto:hosepumps@bredel.com)

## SPX25 and SPX32 heavy duty hose pumps

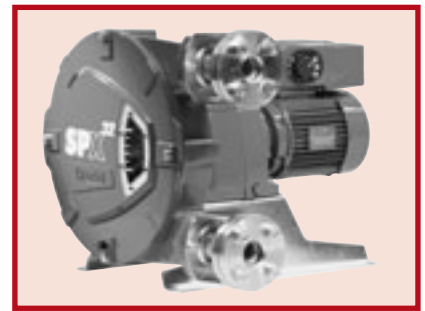
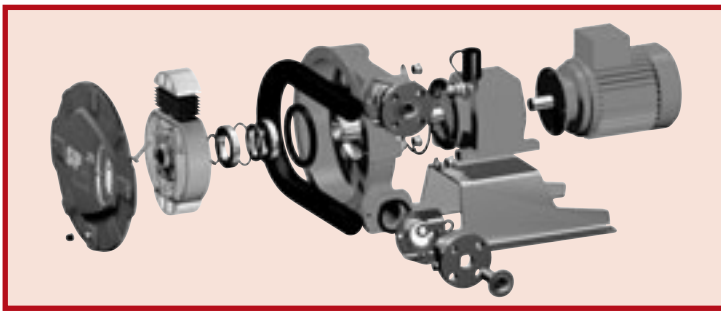

The direct-coupled hose pumps series **SPX25** and **SPX32** offer users improved durability, increased ease of maintenance and uses less valuable plant space.

At the heart of the Bredel **SPX25** and **SPX32** direct-coupled design is a large diameter, high strength twin bearing hub integrated into the pump head. Uniquely, this means the rotor is always fully, and centrally, supported by its own bearings, unlike on a close-coupled design, which relies on the gearbox bearings to carry overhanging pump head loads.

As the pump bearings are incorporated into the SPX pump head, maintenance and set-up times are significantly reduced. In addition the direct-coupled design results in automatic and perfect alignment of the pump head and drive.

On the Bredel **SPX25** and **SPX32** the gearbox actually plugs directly into the pump head and a unique leak zone has been created between the pump head bearings and the gearbox bearing. The leak zone gives effective protection to both and provides early warning in the unlikely event of a lubricant seal failure.

Only 4 bolts on the pump cover of the **SPX25** and **SPX32** allows quick user access to the rotor (e.g. to change the shimming and/or to inspect the pressing shoes), halving the time it takes to carry out such maintenance on similar pumps.

A much simpler hose clamping and flange design is incorporated into the Bredel **SPX25** and **SPX32**, which significantly reduces the amount of time it takes to change the hose, and also improves the effectiveness of the sealing system.

### Features

- Rotor fully supported on its own bearings
- Unique leak zone to fully protect the drive and pump
- cover with only 4 bolts; easy access to shims
- Direct-coupled drive; alignment included in pump concept
- Compact design
- Faster hose changing and improved sealing
- Stainless steel sanitary connectors available (DIN, IDF, RJT, TRI-CLAMP or SMS)
- Standard DIN flange connection, but ASA and JIS upon request available
- Conforms to EHEDG and ATEX
- Drain at lowest point
- IEC and NEMA adaptor available
- Two-year warranty

### Options

- Epoxy pressing shoes
- High and low level control
- Speed sensor

# SPX25 and SPX32

## SPX25 with Breidel Variable Frequency Drive (VFD)

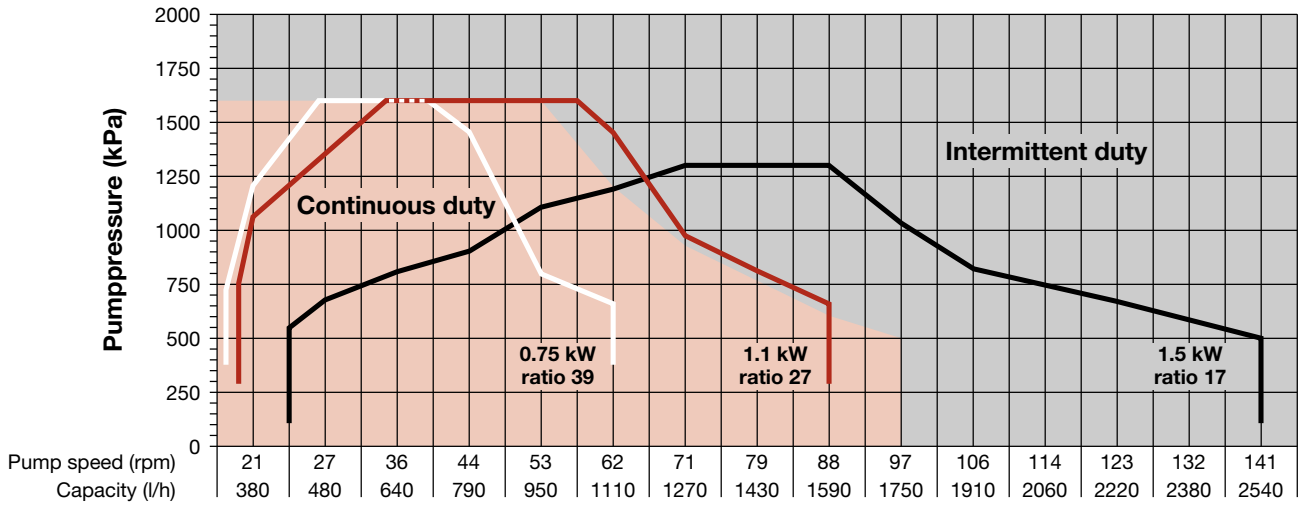

## SPX32 with Breidel Variable Frequency Drive (VFD)

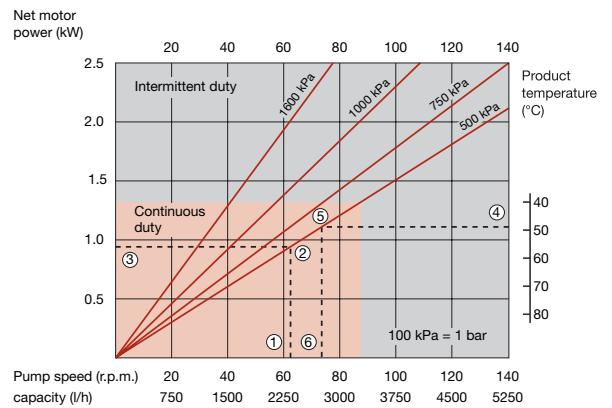
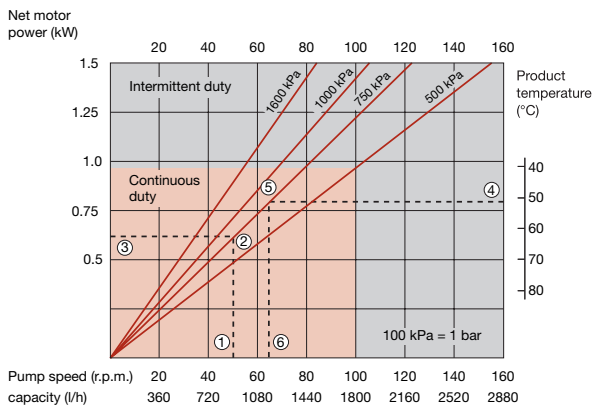
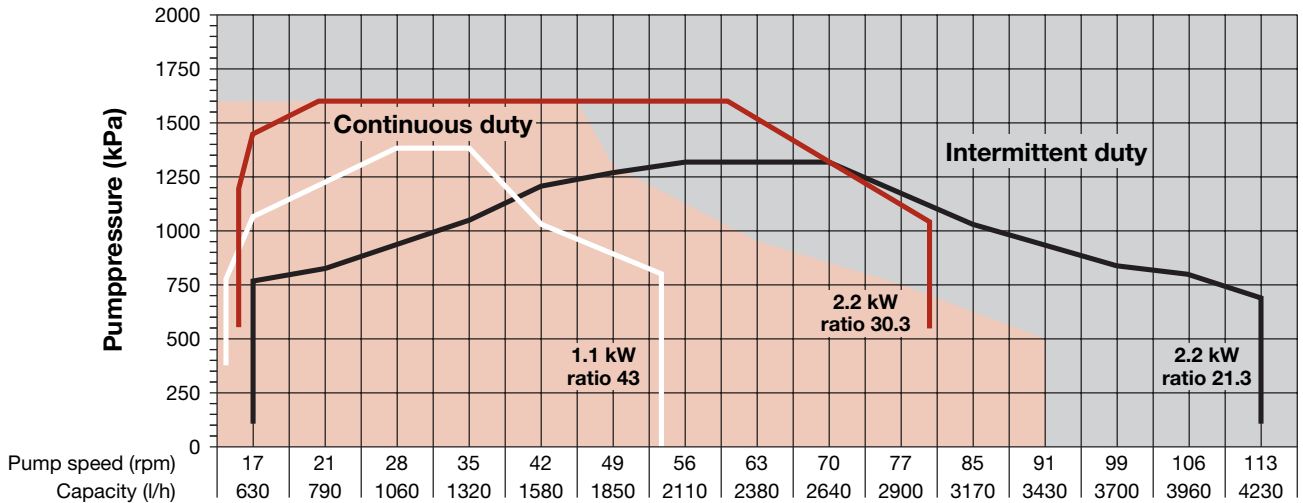

**SPX25** Hose (Ø 25 mm)  
 Minimum starting torque 115 Nm  
 Capacity per revolution 0,3 l

**SPX32** Hose (Ø 32 mm)  
 Minimum starting torque 210 Nm  
 Capacity per revolution 0,625 l

### How to use the curves:

- 1 Flow required indicates pump speed.
- 2 Calculated discharge pressure.
- 3 Net motor power required.
- 4 Product temperature.
- 5 Calculated discharge pressure.
- 6 Maximum recommended pump speed (rpm).

Intermittent duty  
 = 2 hrs max., 1 hr stop.

# SPX25 and SPX32

## Position 1

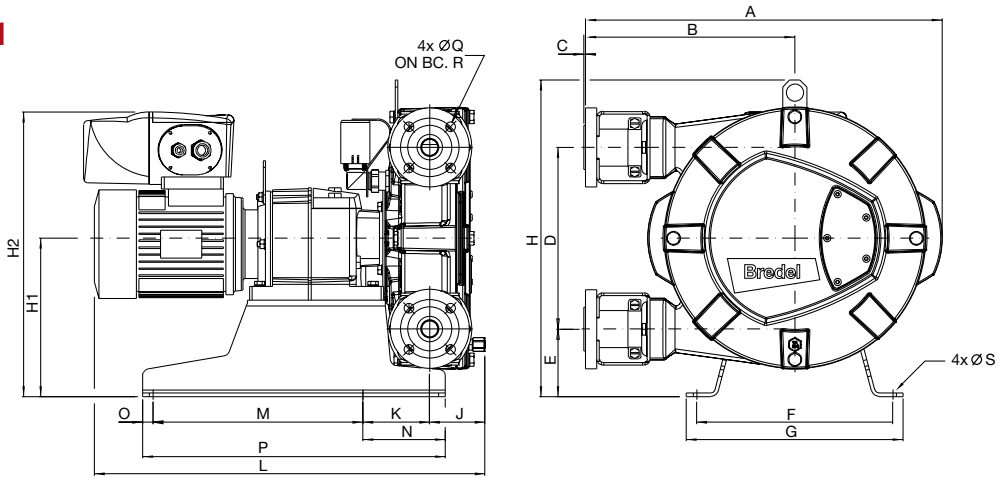

## Position 2

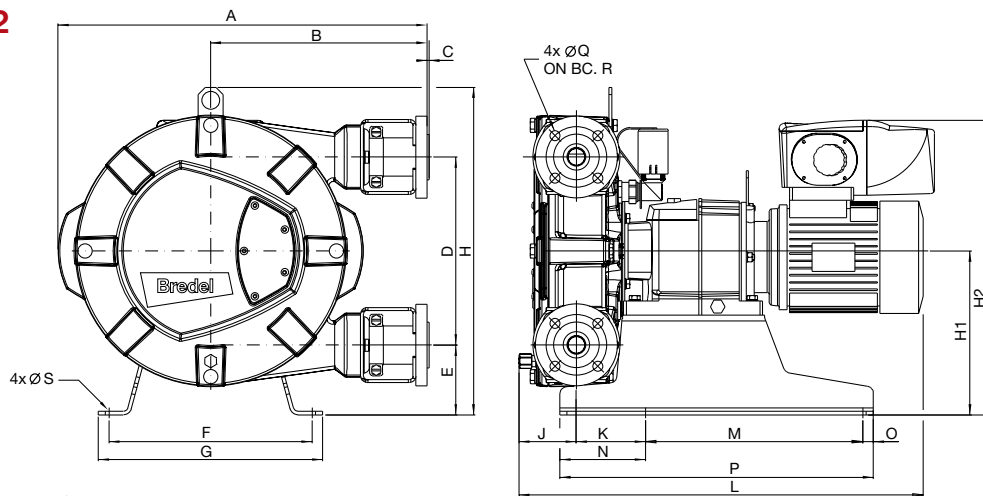

Table position 1 + 2

Type	A	B	C	D	E	F	G	H	H1	H2	J	K	L <sub>min</sub>	L <sub>max</sub>	M	N	O	P	Q	R	S
SPX25	520	306	2.5	264	98	285	315	460	230	423	66	97	548	583	305	120	15	440	ø14	85	ø12
SPX32	631	375	2.5	330	105	330	360	538	270	467	72	92	584	684	370	120	20	510	ø18	100	ø12

## Position 3

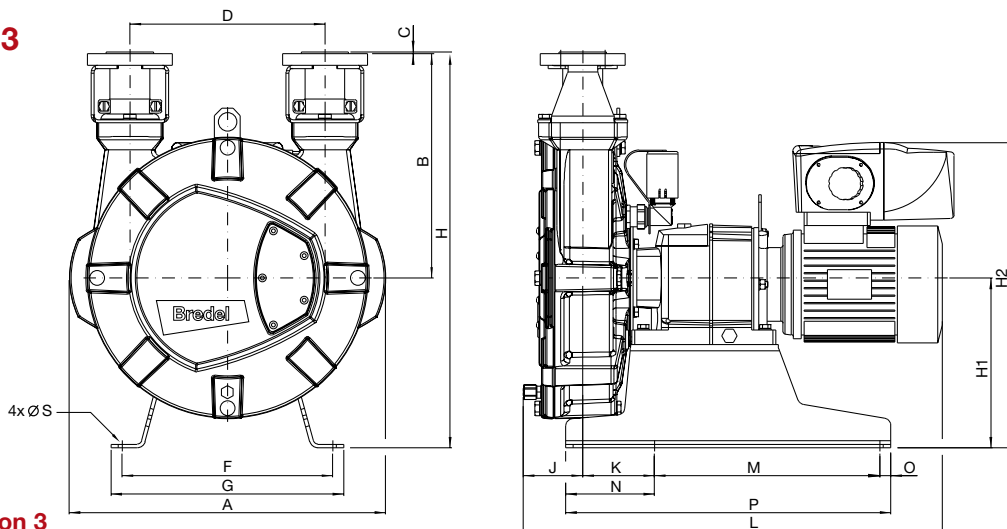

Table position 3

Type	A	B	C	D	E	F	G	H	H1	H2	J	K	L <sub>min</sub>	L <sub>max</sub>	M	N	O	P	Q	R	S
SPX25	428	306	2.5	264	98	285	315	537	230	423	66	97	548	583	305	120	15	440	ø14	85	ø12
SPX32	507	375	2.5	330	105	330	360	648	270	467	72	92	584	684	370	120	20	510	ø18	100	ø12

## Specifications

### Gearbox

---

<b>Description</b>	Co-axial gearbox with helical gear wheels. Standard in 2 or 3-stage executions
<b>Mounting</b>	IM 2001 (IM B35) foot flange motor with splined shaft in horizontal position
<b>Motor</b>	Motor is integrated in the housing of the gearbox to give the smallest overall dimension possible
<b>Options</b>	Motor adaptors according to IEC-B5 or NEMA TC

### Electric motor

---

<b>Description</b>	Motor is specially designed for frequency drive use. Even at 5 Hz, 100% torque remains available on the motor shaft without the need of forced cooling. PTC's standard included.
<b>Protection class</b>	IP55
<b>Insulation class</b>	F
<b>Temperature rise</b>	Within class B.
<b>Voltage/frequency</b>	230/400V 3ph 50Hz

### Bredel Variable Frequency Drive (VFD)

---

<b>Description</b>	The frequency drive is pre programmed and only requires power supply
<b>RFI-filter</b>	Integrated RFI-filter A (industrial level)
<b>Control</b>	Knob for speed regulation and buttons for: start CW/stop/start CCW
<b>Protection class</b>	IP65
<b>Supply</b>	3 versions available; choice depending on local supply: 200-240V ± 10% 50/60 Hz ± 5% 1 ph 200-240V ± 10% 50/60 Hz ± 5% 3 ph 400-480V ± 10% 50/60 Hz ± 5% 3 ph

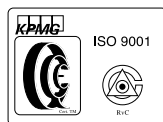

The information contained in this document is believed to be correct but Bredel Hose Pumps B.V. accepts no liability for any errors it contains and reserves the right to alter specifications without notice.

SPX and Bredel are registered trademarks. Bredel: worldwide supplier of industrial high pressure hose pumps.