



Heavy Duty Connectors



The latest version of this
catalogue is also in the Internet
www.odu.de

Section 1	Page
General Information	
Application Examples	5
The ODU Springwire Contact	6
Terms & Definitions	7
Termination Schemes	8

Section 2	Page
Series 207, 208 and 209	
Cylindrical Connectors with Threaded Coupling	11
Housings 207, 208, 209	12
Inserts and Insulation Bodies 207, 208, 209	15
Cable Clamps and Strain Relief	22
Assembly Instructions	24
Tools and Accessories	25

Section 3	Page
Series 308, 309 and 310	
Heavy-Duty Cylindrical Connectors with Bayonet Coupling	27
Housings Type 308	28
Inserts and Insulation Bodies Type 308	30
Housings Type 309	31
Inserts and Insulation Bodies Type 309	37
Housings Type 310	40
Inserts and Insulation Bodies Type 310	43
Cable Strain Relief	45
Assembly Instructions	47
Tools and Accessories	48

Section 4	Page
Custom Connectors	49

Section 5	Page
Technical Information for the User	57
Protection (IP) in acc. with DIN 40 050	58
Insulation Groups / Nominal Voltage / Test Voltage	60
Current Load	61
Derating Factors	62
Current Load for ODU-Contacts	65
Materials	69
Glossary of Terms	70
Conversion Tables	71
Conductance and Resistance for DC Currents	72

Check List / Fax Form	Page
for your inquiries	73

For your notes:

General Information - Application Examples

ODU-Steckverbindingssysteme GmbH & Co. KG / Otto Dunkel GmbH manufactures heavy-duty cylindrical connectors for industrial applications.

The heavy-duty connectors are divided into two groups: Series 207, 208, and 209, and the Series 308, 309, and 310 as well as special connectors.

The **Series 207, 208, and 209** is a family of cylindrical connectors with **threaded coupling system**. They are available in three sizes: 207, 208, 209.

Typical applications are areas where mechanical durability, high reliability, small and compact design, and high packing density are of concern. Examples are industrial measurement and control, testing, and power distribution systems.

The **Series 308, 309 and 310** offers cylindrical connectors with **bayonet coupling system**. This family of connectors is also divided into three sizes: 308, 309, and 310. A few connectors can be supplied with water-tight mounting flanges for IP 67 protection for up to 8 hours submersed at 3 bar, or a neoprene push-pull locking scheme (IP 56).

Usage is in severe industrial environments such as heavy-duty crane and lifting equipment at sea ports, container handling equipment, heavy duty transport systems, mobile cooling equipment, machine tools, railroads, and steel mills.

Custom connectors based on any of the above connector systems are available. They can be designed to application-specific requirements in cooperation with the customer. ODU will work with the customer to define specifications and establish mechanical, electrical, and environmental requirements.

General Information - The Contact Principle

The ODU Springtac™ Contact

The springwire contact is the ingenious invention of Otto Dunkel, the founder of ODU. The figure below shows the concept of the springwire contact with the Springtac™ socket and a solid pin.

The socket has many springwires parallel to the mating direction. The springwires are fixed at the bottom of the socket but are allowed to move at the entrance end of the socket. A guide ring at the entrance to the socket provides easy insertion of the pin and prevents damage to the springwires during the contact mating. The springwires form a resilient gage with many independent contact points along the surface of the pin. This creates an almost constant contact pressure between the pin surface and the springwires. Even a relatively small socket, such as for an AWG #20 pin (1.02 mm dia.), contains at least 15 independent springwires. As the size of the contact increases, so does the number of springwires. The result is a large contact area for efficient current transmission. Springtac™ contacts are available from as small as 0.6 mm to as large as 50 mm diameter.

Contact retention in a connector insulation body is via military style contact clips or via glueing or mechanical pinching.

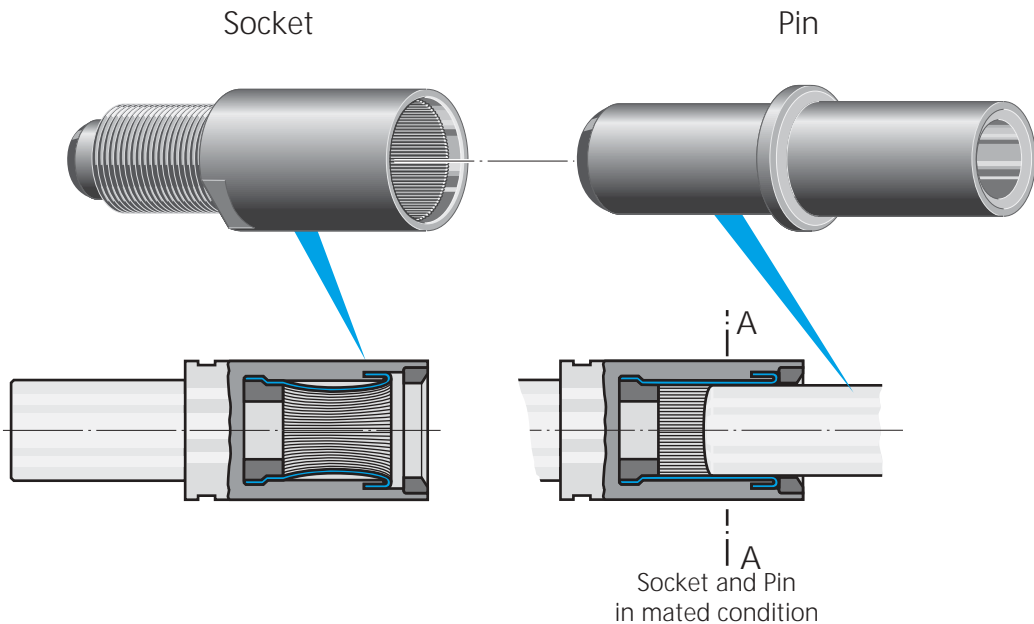

Significant advantages of the ODU Springtac™ contact:

- Very high contact reliability
- Low contact resistance
- High current load
- Excellent performance under vibration
- Low insertion & withdrawal force
- High number of mating cycles
- Long service life

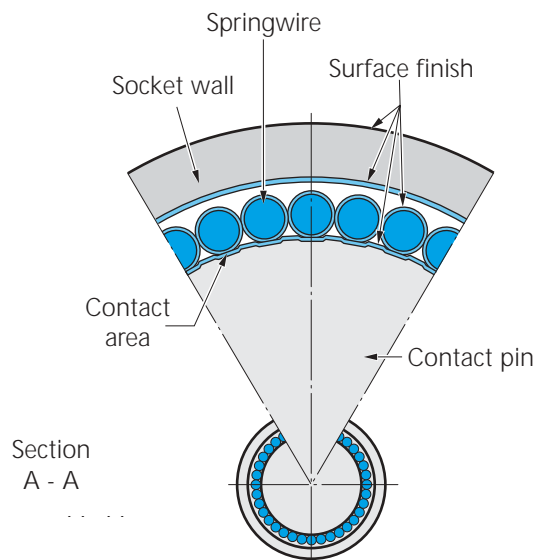

General Information - Terms & Definitions

A typical connector consists of a plug with a cable and a panel-mounted receptacle.

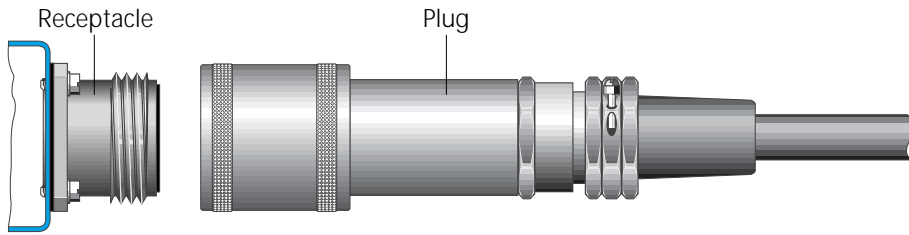

A cable-to-cable connection requires a free receptacle and a plug.

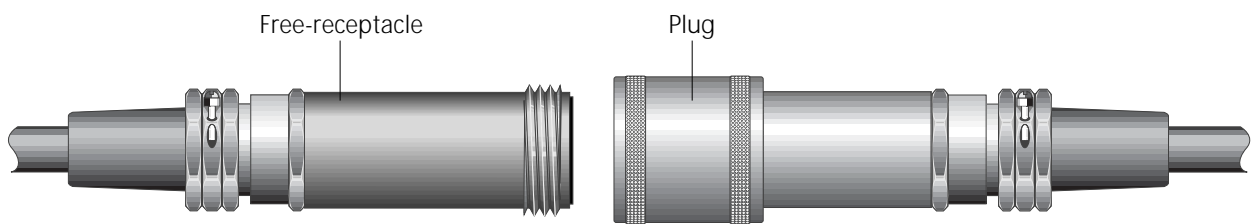

A connector (receptacle, free receptacle or plug) generally has a housing, an insulation body, and contacts. In-line receptacles and plugs also can have a cable clamp with cable strain relief.

Receptacle

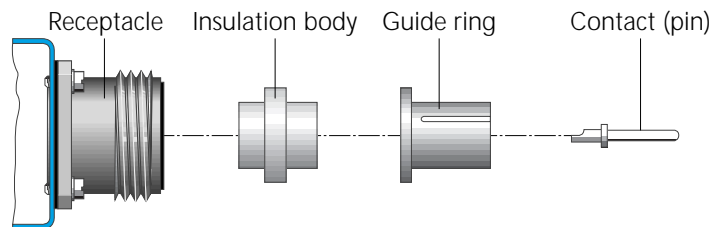

In-Line Receptacle

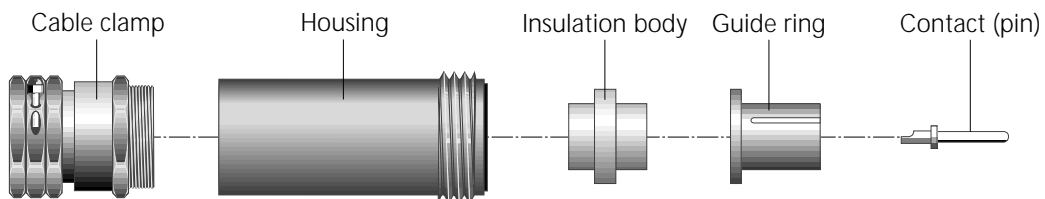

Plug

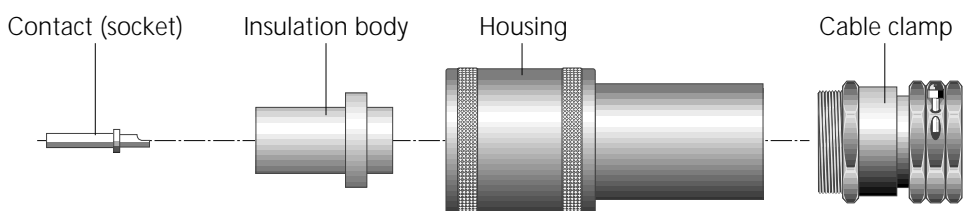

General Information - Different Types of Contact Termination

All ODU heavy-duty connectors have pin and socket contacts. ODU offers no button contacts due to their inherent unreliability.

Insulation bodies and inserts with pins can be mounted in a receptacle or plug. As a rule, sockets are preferred inside the part of the connection which supplies the current. This is to prevent injury due to accidental touching.

The type of termination determines the mounting of the contacts inside the insulation body.

Available Terminations are:

- **Threaded Stud**
- **Solder Cup**
- **Crimp**

Threaded stud and **solder cup termination** requires that the contacts are mounted permanently (fixed) inside the insulation body. Insulation bodies with fixed contacts are called inserts. Inserts are ordered with one part number which includes the contacts.

Crimp contacts are snap-in contacts and can be removed from the insulation body. They are first crimped to the cable and then inserted into the insulation body. When ordering crimp inserts, the **contacts** and the **insulation bodies** have separate part numbers. Crimp contacts can be removed after installation, please see page 9 for details.

Crimp Termination

Crimp termination provides a long-lasting, corrosion-free, and reliable connection between the contact and the conductor.

Crimping cold-forms the conductors and the crimp barrel of the contact. The result is a gas-tight connection with high contact-to-cable retention force.

Crimping is suitable for all contact sizes, from the smallest to the largest contact diameter.

The 8-point crimp tool is used for small cable cross sections from 0.5 - 2.5 mm². Larger cable cross sections require a hexagonal crimp tool. The dimension across a hexagonal crimp, measured from corner to corner, should not increase over the original crimp barrel outer diameter. The cable insulation (jacket) is not damaged during crimping and can butt up against the endface of the crimp barrel.



Cross Section of a Hexagonal Crimp

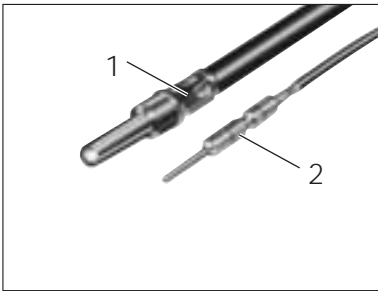

Contact with Hexagonal (1) and 8-Point Crimp (2).

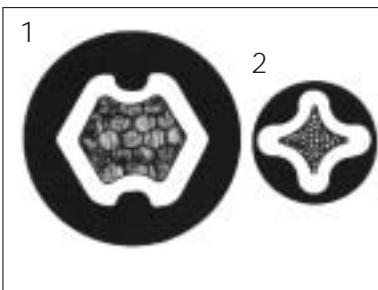

Polished Cut-Away View of a Hexagonal (1) and 8-Point Crimp (2)

In an 8-Point crimp two crimps are behind each other.

For your notes:

Section 2

Series 207, 208 and 209

Cylindrical Connectors with Threaded Coupling System

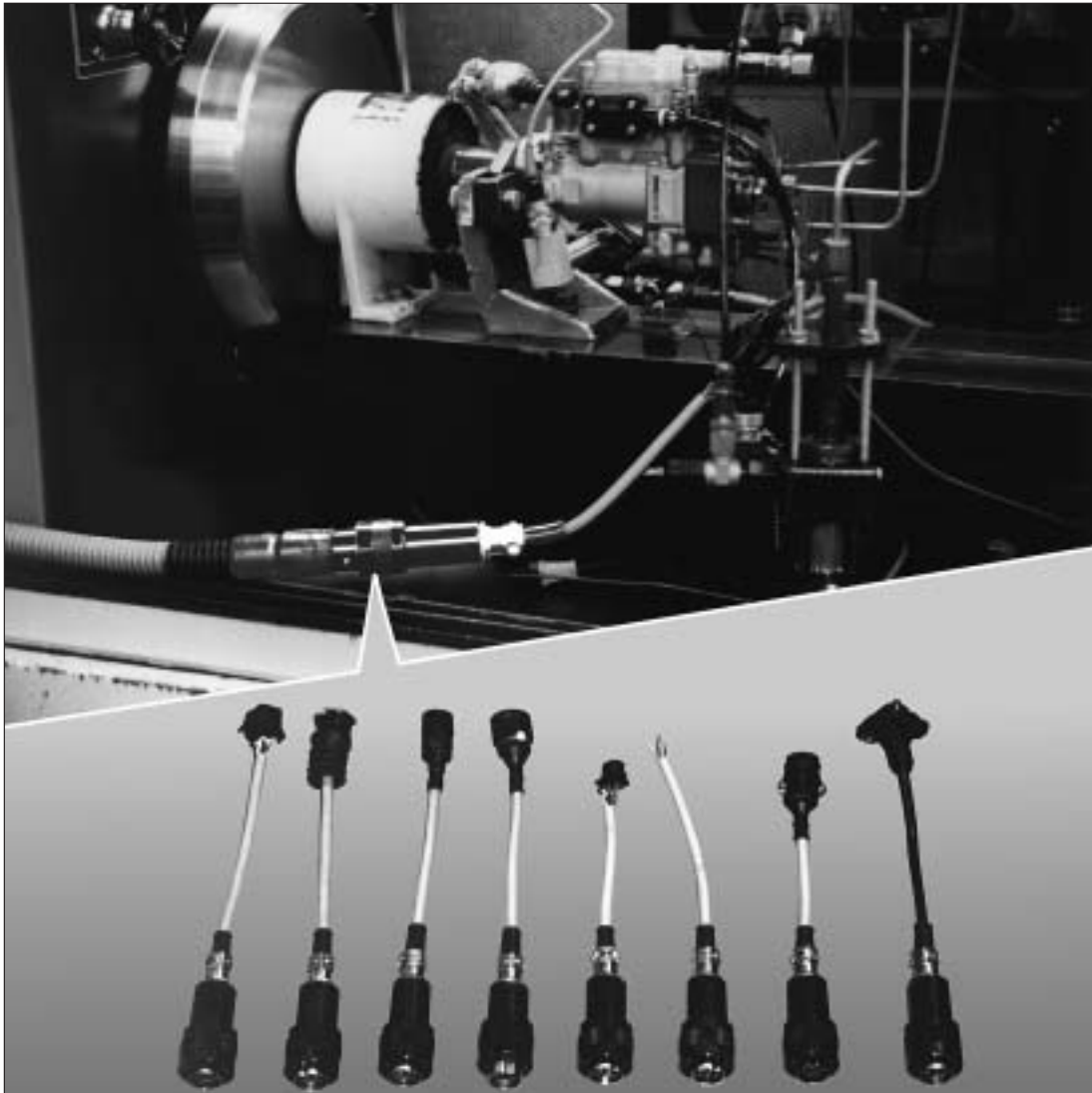

Technical Information

Positions:	2 - 37
Test Voltage:	to 2750 V AC
Max. Single Contact Load:	to 210 A
Insulation Body:	Thermoplastic, glass-filled, UL 94 V-0 or PTFE (Crimp Termination)
Insert Material:	Duroplast, glass-filled, UL 94 V-0 (Solder Termination)
Contact:	Springwire socket and solid pin
Contact Finish:	Silver-plated, passivated
Housing Material:	Aluminum Alloy or Brass, Ni-plated
Housing Finish:	Black anodized
Coupling System:	Threaded Ring
Environmental Protection:	in mated and locked condition up to IP 67

Series 207, 208, 209 Straight Receptacle

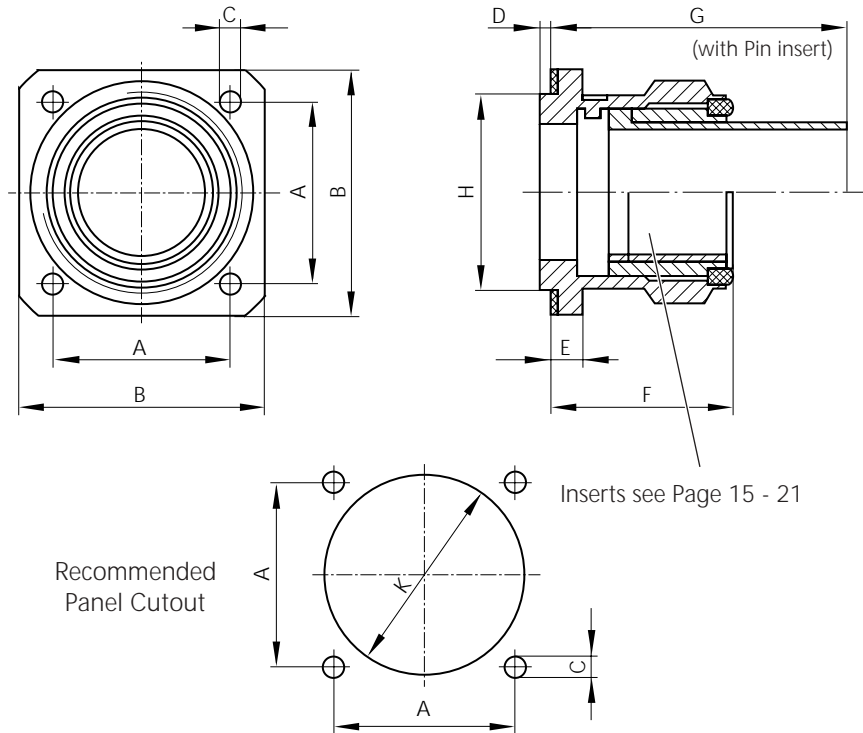

(All dimensions in mm)

Series	Material and Finish	Part Number	Dim. A	Dim. B	Dim. Ø C	Dim. D	Dim. E	Dim. F	Dim. G	Dim. Ø H	Dim. Ø K
207	Alu-anodized Brass-Ni-plated	207.010.000.632.000	24	32	3,2	1,5	4	23,5	38,5	25,5	26
		207.010.000.304.000									
208	Alu-anodized Brass-Ni-plated	208.010.000.632.000	34	46	3,3	2	6	27	41	32	32,5
		208.010.000.304.000									
209	Alu-anodized Brass-Ni-plated	209.010.000.632.000	48	60	4,5	3	7	33	55	46	46,5
		209.010.000.304.000									

Straight plug

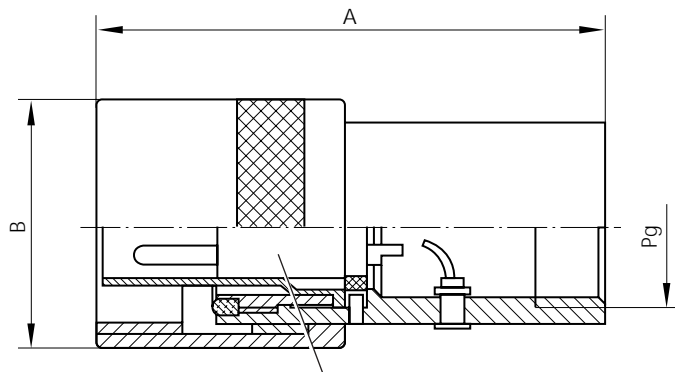

Inserts see Page 15 - 21

(All dimensions in mm)

Series	Material and Finish	Part Number ¹⁾	Dim. A	Dim. B	Cable Size Pg ¹⁾	Comments
207	Alu-anodized Brass-Ni-plated	207.020.000.632.000	70	32	16	L = in mated condition with 207.010 L = 79
		207.020.000.304.000				
208	Alu-anodized Brass-Ni-plated	208.020.000.632.000	92	45	21	L = in mated condition with 208.010 L = 101
		208.020.000.304.000				
209	Alu-anodized Brass-Ni-plated	209.020.000.632.000	108	60	36	L = in mated condition with 209.010 L = 123
		209.020.000.304.000				

¹⁾ Cable size is not shown in Part Number (see Page 22 and 23)
Assembly Instructions Page 24

Series 207, 208, 209 Free Receptacle

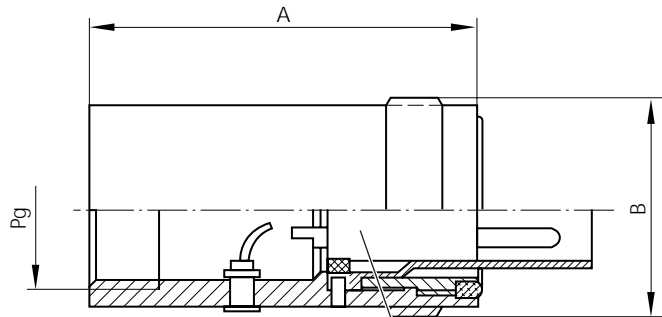

Inserts see Page 15 - 21

(All dimensions in mm)

Series	Material and Finish	Part Number ¹⁾	Dim. A	Dim. B	Cable Size Pg ¹⁾	Comments
207	Alu-anodized Brass-Ni-plated	207.030.000.632.000 207.030.000.304.000	55	29	16	In mated condition with 207.020 L = ~ 110
208	Alu-anodized Brass-Ni-plated	208.030.000.632.000 208.030.000.304.000	75	40	21	In mated condition with 208.020 L = ~ 150
209	Alu-anodized Brass-Ni-plated	209.030.000.632.000 209.030.000.304.000	100	56	36	In mated condition with 209.020 L = ~ 190

Right-Angle Plug

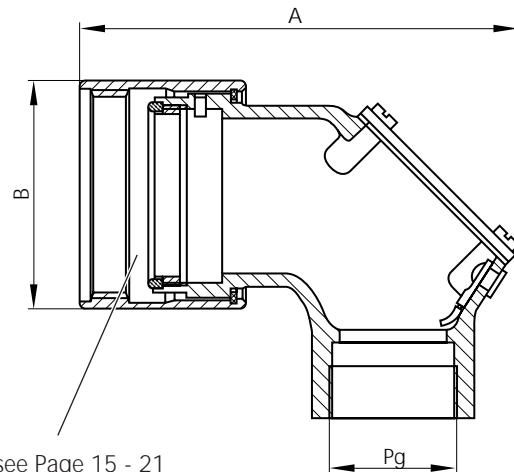

Inserts see Page 15 - 21

(All dimensions in mm)

Series	Material and Finish	Part Number ¹⁾	Dim. A	Dim. B	Cable Size Pg ¹⁾	Comments
207	Alu-anodized Brass-Ni-plated	207.040.000.632.000 207.040.000.304.000	~ 83	34	16	L = in mated condition with 207.010 L = ~ 90
208	Alu-anodized Brass-Ni-plated	208.040.000.632.000 208.040.000.304.000	~ 92	45	21	L = in mated condition with 208.010 L = ~ 100
209	Alu-anodized Brass-Ni-plated	209.040.000.632.000 209.040.000.304.000	~ 113	60	29	L = in mated condition with 209.010 L = ~ 125

¹⁾ Cable size is not shown in Part Number (see Page 22 and 23)
For Assembly Instructions Page 24

Series 207, 208, 209

Cover for Receptacle and Plug

Cover for Plug (Straight and Right-Angle)



Series	Material and Finish	Part Number Cover for Receptacle	Part Number Cover for Plug	Comments
207	Alu-anodized	207.097.002.632.000	207.097.001.632.000	
	Brass-ni-plated	207.097.002.304.000	207.097.001.304.000	
208	Alu-anodized	208.097.002.632.000	208.097.001.632.000	
	Brass-Ni-plated	208.097.002.304.000	208.097.001.304.000	
209	Alu-anodized	209.097.002.632.000	209.097.001.632.000	
	Brass-Ni-plated	209.097.002.304.000	209.097.001.304.000	

Extension for Receptacle

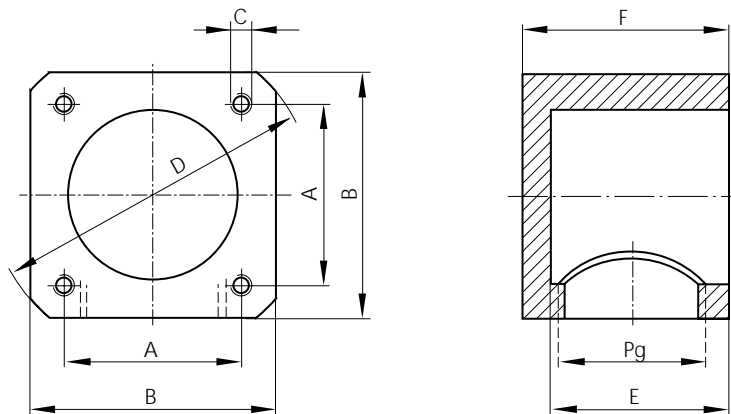





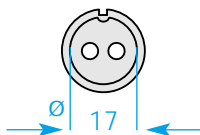

(All dimensions in mm)

Series	Material and Finish	Part Number ¹⁾	Dim. A	Dim. B	Dim. C	Dim. D	Dim. E	Dim. F	Dim. Pg ¹⁾
207	Alu-anodized	207.095.211.632.000	24	32	M3 / 7 mm deep	Ø 46	26	30	16
	Brass-Ni-plated	207.095.211.304.000							
208	Alu-anodized	208.095.211.632.000	34	46	M3 / 10 mm deep	Ø 56	45	50	16
	Brass-Ni-plated	208.095.211.304.000							
209	Alu-anodized	209.095.211.632.000	48	60	M4 / 12 mm deep	Ø 79	52	55	29
	Brass-Ni-plated	209.095.211.304.000							

¹⁾ Cable Size not shown in Part Number (see Page 22 and 23)
Assembly instructions see Page 24

Type 207
Inserts for Solder Contacts

	Pos.	Part Number	Contact Ø (mm)	Test Voltage VDE 0627	Single Contact Load (max.)	Term. Cross Section	Comments
	2	Socket Insert 207.703.150.002.000 Pin Insert 207.803.150.002.150	3,0	1750 V AC	40 A	2,5 mm ²	
	2+⊥	Socket Insert 207.703.152.003.000 Pin Insert 207.803.152.003.150	3,0	1750 V AC	40 A	2,5 mm ²	
	3+⊥	Socket Insert 207.702.150.004.000 Pin Insert 207.802.150.004.150	2,0	1750 V AC	40 A	2,5 mm ²	
	4+⊥	Socket Insert 207.702.150.005.000 Pin Insert 207.802.150.005.150	2,0	1250 V AC	35 A	1,5 mm ²	
	6+⊥	Socket Insert 207.702.150.007.000 Pin Insert 207.802.150.007.150	2,0	1250 V AC	35 A	1,5 mm ²	
	9+⊥	Socket Insert 207.701.150.010.000 Pin Insert 207.801.150.010.150	1,0	1250 V AC	24 A	1,0 mm ²	

Additional contact inserts upon request.

Contact finish silver, other surface finish upon request.

⊥ = Ground, first-make, last-break

 = For additional information see Section 5 "Technical Information"

Type 207 Insulation Bodies for Crimp Contacts

	Pos.	Part Number	Contact Ø (mm)	Test Voltage VDE 0627	Single Contact Current Load (max.)	Comments
	2+⊥	Socket Insulation Body 207.703.001.003.000 Pin Insulation Body 207.803.001.003.150	3,0	1750 V AC	40 A	Without contacts (see below)
	6+⊥	Socket Insulation Body 207.702.001.007.000 Pin Insulation Body 207.802.001.007.150	2,0	1250 V AC	35 A	Without contacts (see below)
	31	Socket Insulation Body 207.742.001.031.000 Pin Insulation Body 207.842.001.031.150	0,76	750 V AC	11 A	Without contacts (see below)
	2+⊥	Socket Insulation Body 207.702.003.003.000 Pin Insulation Body 207.802.003.003.150	2,0	1250 V AC	35 A	Material PTFE Without contacts (see below)
	4+⊥	Socket Insulation Body 207.702.003.005.000 Pin Insulation Body 207.802.003.005.150	2,0	1250 V AC	35 A	Material PTFE Without contacts (see below)

⊥ = Ground, first-make, last-break

■ = Additional information see Section 5 "Technical Information"

Crimp Contacts

For Insulation body:	Part Number Std. Contact	Part Number Grd. Contact	Term. Cross Section. ¹⁾	Part Number Dummy Contact	Removal Tool ²⁾ / Crimp Tool ³⁾
Socket 207.703.001.003.000	170.382.000.201.000	170.382.000.201.000	2,5 mm ²	021.341.136.924.000	087.170.136.000.000
Pin 207.803.001.003.150	180.334.000.301.000	180.335.000.301.000	2,5 mm ²	021.341.136.924.000	080.000.012.000.000
Socket 207.702.001.007.000	170.381.000.201.000	170.381.000.201.000	1,5 mm ²	021.341.135.924.000	087.170.364.000.000
Pin 207.802.001.007.150	180.332.000.301.000	180.333.000.301.000	1,5 mm ²	021.341.135.924.000	080.000.014.000.000
Socket 207.742.001.031.000	170.361.700.207.000	-	AWG 22	021.341.123.923.000	087.170.361.000.000
Pin 207.842.001.031.150	180.381.000.307.000	-	AWG 22	021.341.123.923.000	080.000.014.000.000
Socket 207.702.003.003.000	170.577.100.200.000	170.577.100.200.000	1,5 mm ²	-	No removal tool required.
Pin 207.802.003.003.150	180.566.000.301.000	180.567.000.301.000	1,5 mm ²	-	080.000.014.000.000
Socket 207.702.003.005.000	170.577.100.200.000	170.577.100.200.000	1,5 mm ²	-	No removal tool required.
Pin 207.802.003.005.150	180.566.000.301.000	180.567.000.301.000	1,5 mm ²	-	080.000.014.000.000

Contact Finish: .201. and .301. = silver-plated, .207. and .307. = gold-plated, .200. = Inconel Springs.

¹⁾ Smaller termination cross sections on request. ²⁾ ³⁾ Removal Tool and Crimp are the same for Pin and Socket.

Type 208
Inserts for Solder Contacts

	Pos.	Part Number	Contact Ø (mm)	Test Voltage.	Single Contact Load (max.)	Term. Cross Section	Comments
	2	Socket Insert 208.705.150.002.105 Pin Insert 208.805.150.002.150	5,0	1750 V AC	80 A	10 mm ²	
	4+ $\frac{1}{2}$	Socket Insert 208.704.150.005.105 Pin Insert 208.804.150.005.150	4,0	1750 V AC	50 A	6 mm ²	
	6+ $\frac{1}{2}$	Socket Insert 208.703.150.007.105 Pin Insert 208.803.150.007.150	3,0	1750 V AC	40 A	2,5 mm ²	
	9+ $\frac{1}{2}$	Socket Insert 208.702.150.010.105 Pin Insert 208.802.150.010.150	2,0	1250 V AC	35 A	1,5 mm ²	
	11+ $\frac{1}{2}$	Socket Insert 208.745.150.012.105 Pin Insert 208.845.150.012.150	1,5	1750 V AC	22 A	0,75 mm ²	
	15+ $\frac{1}{2}$	Socket Insert 208.702.153.016.105 Pin Insert 208.802.152.016.150	2,0	1250 V AC	35 A	1,5 mm ²	
	23+ $\frac{1}{2}$	Socket Insert 208.701.150.024.105 Pin Insert 208.801.150.024.150	1,0	1250 V AC	24 A	1,0 mm ²	

Additional contact inserts upon request.



Contact finish silver, other surface finish upon request.

$\frac{1}{2}$ = Ground, first-make, last-break

 = For additional information see Section 5 "Technical Information"

Type 208

Insulation Bodies for Crimp Contacts

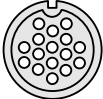
	Pos.	Part Number	Contact Ø (mm)	Test Voltage VDE 0627	Single Contact Load (max.)	Comments
	4+ ⊥	Socket Insulation Body 208.703.001.005.105 <hr/> Pin Insulation Body 208.803.001.005.150	3,0	2250 V AC	40 A	Without contacts (see below)
	6+ ⊥	Socket Insulation Body 208.703.001.007.105 <hr/> Pin Insulation Body 208.803.001.007.150	3,0	2250 V AC	40 A	Without contacts (see below)
	15+ ⊥	Socket Insulation Body 208.702.001.016.105 <hr/> Pin Insulation Body 208.802.001.016.150	2,0	1250 V AC	35 A	Without contacts (see below)

⊥ = Ground, first-make, last-break

 = Additional information see Section 5 "Technical Information"

Crimp Contacts

For Insulation body:		Part Number Std. Contact	Part Number Grd. Contact	Contact Cross sec-	Part Number Dummy Contact	Removal Tool ²⁾ Crimp Tool ³⁾
Socket	208.703.001.005.105	170.382.000.201.000	170.382.000.201.000	2,5 mm ²	021.341.136.924.000	087.170.136.000.000
Pin	208.803.001.005.150	180.334.000.301.000	180.335.000.301.000	2,5 mm ²	021.341.136.924.000	080.000.012.000.000
Socket	208.703.001.007.105	170.382.000.201.000	170.382.000.201.000	2,5 mm ²	021.341.136.924.000	087.170.136.000.000
Pin	208.803.001.007.150	180.334.000.301.000	180.335.000.301.000	2,5 mm ²	021.341.136.924.000	080.000.012.000.000
Socket	208.702.001.016.105	170.381.000.201.000	170.381.000.201.000	1,5 mm ²	021.341.135.924.000	087.170.364.000.000
Pin	208.802.001.016.150	180.332.000.301.000	180.333.000.301.000	1,5 mm ²	021.341.135.924.000	080.000.014.000.000

Contact Finish: .201. and .301. = silver-plated, .207. and .307. = gold-plated.

¹⁾ Smaller cross section on request. ²⁾ ³⁾ Removal Tool and Crimp Tool same for Pin and Socket.

Type 209
Inserts for Solder Contacts

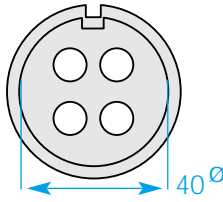
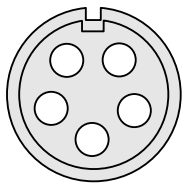
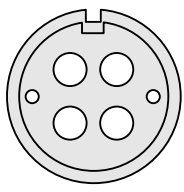
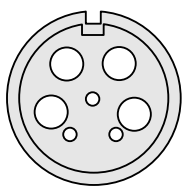
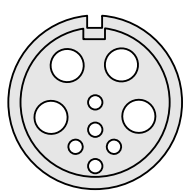
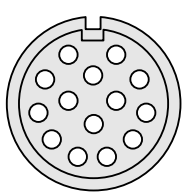
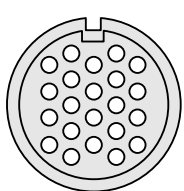
	Pos.	Part Number	Contact Ø (mm)	Test Voltage.	Single Contact Load (max.)	Term. Cross Section	Comments
	3+⊥	Socket Insert 209.708.150.004.108 <hr/> Pin Insert 209.808.150.004.150	8,0	1750 V AC	145 A	25 mm ²	
	4+⊥	Socket Insert 209.706.152.005.108 <hr/> Pin Insert 209.806.150.005.150	6,0	2250 V AC	110 A	16 mm ²	
	3+⊥ +2 Pi	Socket Insert 209.700.150.006.108 <hr/> Pin Insert 209.800.150.006.150	6,0 1,5	2750 V 1750 V AC	110 A 35 A	16 mm ² 1,5 mm ²	
	3+⊥ +3 S	Socket Insert 209.700.153.007.108 <hr/> Pin Insert 209.800.153.007.158	5,0 1,5	2750 V 1750 V AC	80 A 35 A	10 mm ² 1,5 mm ²	
	3+⊥ +5 S	Socket Insert 209.700.152.009.108 <hr/> Pin Insert 209.800.152.009.150	5,0 1,5	2750 V 1750 V AC	80 A 35 A	10 mm ² 1,5 mm ²	
	13+⊥	Socket Insert 209.703.153.014.108 <hr/> Pin Insert 209.803.153.014.150	3,0	2250 V AC	45 A	4,0 mm ²	
	21+⊥	Socket Insert 209.746.150.022.108 <hr/> Pin Insert 209.846.150.022.150	2,3	1750 V AC	40 A	2,5 mm ²	

Additional contact inserts upon request.

Contact finish silver, other surface finish upon request.

⊥ = Ground, first-make, last-break

Pi = Pilot contact, last mating

S = Signal contact

 = For additional information see Section 5 "Technical Information"

Type 209

Inserts for Solder Contacts

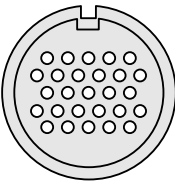
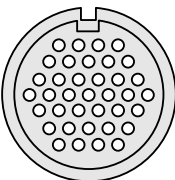
	Pos.	Part Number	Contact Ø (mm)	Test Voltage VDE 0627	Single Contact Load (max.)	Term. Cross Section	Comments
	26+ ⊥	Socket Insert 209.745.150.027.108	1,5	1750 V AC	35 A	1,5 mm ²	
		Pin Insert 209.845.150.027.150					
	36+ ⊥	Socket Insert 209.745.152.037.108	1,5	1750 V AC	35 A	1,5 mm ²	
		Pin Insert 209.845.152.037.150					

Additional contact inserts upon request.

Contact finish silver, other surface finish upon request.

⊥ = Ground, first-make, last-break

 = For additional information see Section 5 "Technical Information"

For your notes:

Type 209
Insulation Bodies for Crimp Contacts

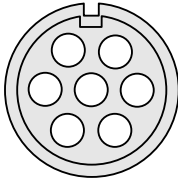
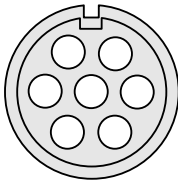
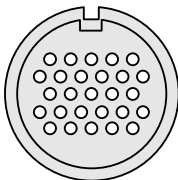
	Pos.	Part Number	Contact Ø (mm)	Test Voltage VDE 0627	Single Contact Load (max.) (Crimp-Contact)	Comments
	6+ ⊥	Socket Insulation Body 209.705.002.007.108 Pin Insulation Body 209.805.002.007.150	5,0	2250 V AC	80 A	Without contacts (see below)
	6+ ⊥	Socket Insulation Body 209.705.003.007.108 Pin Insulation Body 209.805.003.007.150	5,0	2250 V AC	80 A	Insulation Body PTFE Without contacts (see below)
	26+ ⊥	Socket Insulation Body 209.745.001.027.108 Pin Insulation Body 209.845.001.027.150	1,5	1750 V AC	35 A	Without contacts (see below)

⊥ = Ground, first-make, last-break

 = Additional information see Section 5 "Technical Information"

Crimp Contacts

For Insulation body:	Part Number Std. Contact	Part Number Grd. Contact	Term. Cross Section ¹⁾	Part Number Dummy Contact	Removal Tool ²⁾ / Crimp Tool ³⁾
Socket 209.705.002.007.108	170.633.000.201.000	170.634.000.201.000	10,0 mm ²	021.341.141.924.000	087.170.391.000.000
Pin 209.805.002.007.150	180.633.000.301.000	180.633.000.301.000	10,0 mm ²	021.341.142.924.000	921.000.005.000.025 ⁴⁾
Socket 209.705.003.007.108	170.631.100.200.000	170.632.100.200.000	10,0 mm ²	021.341.157.304.000	No Crimp Tool required..
Pin 209.805.003.007.150	180.631.000.301.000	180.631.000.301.000	10,0 mm ²	021.341.158.304.000	921.000.005.000.025 ⁴⁾
Socket 209.745.001.027.108	170.370.000.201.000	170.370.000.201.000	1,5 mm ²	021.341.131.922.000	087.170.137.000.000
Pin 209.845.001.027.150	180.370.000.301.000	180.371.000.301.000	1,5 mm ²	021.341.132.922.000	080.000.014.000.000

Contact Finish: .201. and .301. = silver-plated, .207. and .307. = gold-plated, .200. = Inconel springs.

¹⁾ Smaller cross section on request. ²⁾ Removal Tool and Crimp Tool for Pin and Socket.

⁴⁾ Crimp Tool: 080.000.026.000.000
Crimp Dies: 921.000.005.000.025

Series 207, 208, 209

Cable Clamp and Strain Relief

The ODU-Cable clamps with strain relief are available for all connectors shown in this catalog.

When connecting cables to electrical equipment, tools or machines, it is imperative that an effective cable strain relief is provided in accordance with VDE and other local standards and regulations. The cable clamp assemblies with the strain relief shown in this catalog meet various VDE requirements and contribute to the functionality of the connector when used with electrical equipment.

Selected Technical Data and Features

Material:	Brass Ni-plated
Sealing:	Neoprene Gasket
Sizes:	Pg 16 to Pg 36
	The cable clamp entry for each connector has the largest possible Pg size. The part number for the strain relief is composed of the Pg size and the cable outer diameter. It may be necessary to install the included reduction units to accommodate smaller cable diameters.

Cable Clamp with Strain Relief for IP 55 Protection



Cable Ø	Part Number Pg 16	Part Number Pg 21	Part Number Pg 29	Part Number Pg 36
5,5 - 6,0	026.416.055.060.000			
6,5 - 10,0	026.416.065.100.000			
9,5 - 16,0	026.416.095.160.000			
12,0 - 21,0		026.421.120.210.000	026.429.120.210.000	026.436.120.210.000
19,0 - 30,0			026.429.190.300.000	026.436.190.300.000
25,0 - 37,0				026.436.250.370.000

Series 207, 208, 209

**Cable Clamp with Strain Relief
and Cable Bending Protection Sleeve (IP 55)**



Cable Ø	Part Number Pg 16	Part Number Pg 21	Part Number Pg 29	Part Number Pg 36
3,5 - 5,0	026.516.035.050.000			
5,5 - 7,0	026.516.055.070.000	026.521.055.070.000		
7,5 - 9,0	026.516.075.090.000	026.521.075.090.000	026.529.075.090.000	
9,0 - 11,0	026.516.090.110.000	026.521.090.110.000	026.529.090.110.000	
11,5 - 13,0	026.516.115.130.000	026.521.115.130.000	026.529.115.130.000	026.536.115.130.000
13,5 - 15,0	026.516.135.150.000	026.521.135.150.000	026.529.135.150.000	026.536.135.150.000
15,0 - 17,0		026.521.150.170.000	026.529.150.170.000	026.536.150.170.000
17,0 - 19,0		026.521.170.190.000	026.529.170.190.000	026.536.170.190.000
18,0 - 20,0		026.521.180.200.000	026.529.180.200.000	026.536.180.200.000
21,0 - 23,0			026.529.210.230.000	026.536.210.230.000
23,0 - 25,0			026.529.230.250.000	026.536.230.250.000
23,0 - 26,0				026.536.230.260.000
27,0 - 30,0				026.536.270.300.000
30,0 - 33,0				026.536.300.330.000
32,0 - 35,0				026.536.320.350.000

Cable Clamp with Environmental Seal (Protection IP 68)

Water- and oil-tight cable clamp for wide range of temperatures
from - 40 °C to + 125 °C



Cable Ø	Part Number Pg 16	Part Number Pg 21	Part Number Pg 29	Part Number Pg 36
5,4 - 13,4	026.616.054.134.000	026.621.054.134.000		
7,0 - 15,0			026.629.070.150.000	
11,9 - 21,9		026.621.119.219.000	026.629.119.219.000	026.636.119.219.000
17,8 - 29,8			026.629.178.298.000	026.636.178.298.000
25,0 - 39,0				026.636.250.390.000

Series 207, 208 and 209 Assembly Instructions

Part Descriptions	
1	Spacer Ring (only for socket inserts Type 208 & 209)
2	Socket Insert
3	Ground Cable
4	Cable
5	Gasket
6	Threaded Ring
8	Housing with Coupling Nut
9	Guide Ring
10	Pin Insert
11	Stripped Conductor
13-20	Cable Strain Relief

= order separately

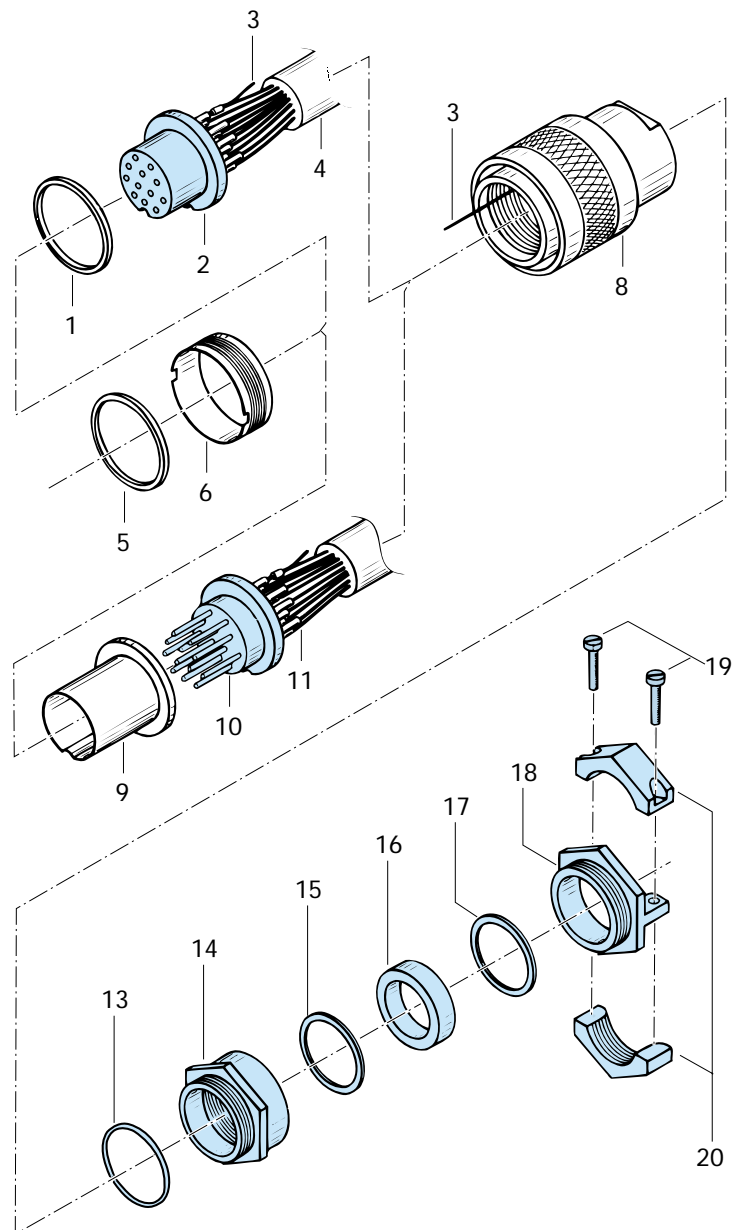
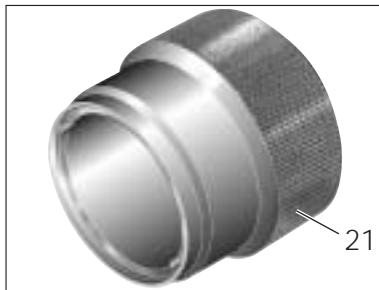

Assembly Tool

for Series 207, 208 and 209

for Series	Part Number for Assembly Tool
207	207.098.000.300.000
208	208.098.000.300.000
209	209.098.000.719.000

Assembly Instructions

- Slide cable clamp (13-20) and housing (8) over cable (4)
- Connect ground strap (3) to ground conductor in cable (4)
- Strip conductors (11) and solder to contacts.
- Inserts (2 or 10) in housing (8), watch out for alignment key.
- With pin inserts (10) use guide ring (9), with socket inserts (2) use spacer ring (1)
- Tighten threaded ring (6) with assembly tool (21)
- Fasten seal (5) with RTV or similar material into groove

Instruction about blowtorch soldering > 6 mm²

During heat-stress it can come to a damage on the contact-elements on the insulating materials as well. (Limit temperature 120°C)

Remedy: Put the inserts into the water. (If possible, distilled water)

Attention! Warmed water at 35°C must be renewed.

After the solder process the connector has to be carefully dried .

Recommended water level →

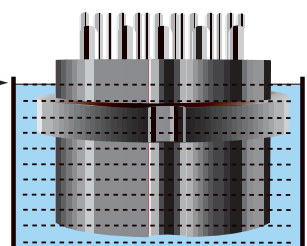

Series 207, 208 and 209 Tools and Accessories

Crimp tools have a safety release which opens when the correct crimp pressure is reached. Premature opening of the crimp tool is thereby prevented.



Removal Tool for Crimp Contacts

for Ø	Part Number for Removal Tool
0,76	087.170.361.000.000
1,5	087.170.137.000.000
2,0	087.170.364.000.000
3,0	087.170.136.000.000
4,0	087.170.367.000.000
5,0	087.170.391.000.000

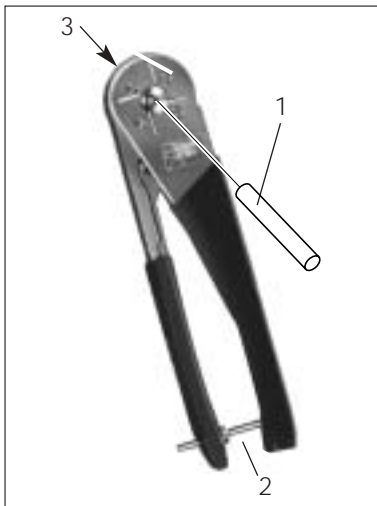

8-Point Crimp Tool adjustable for AWG #22 + 1.5 mm² termination cross section. To adjust use gauge pin (1) and operate at point (2) (see adjustment table below). A contact positioner (3) for easy positioning of the crimp contact is available on request.

A semi-automatic pneumatic 8-point crimp tool can be supplied.

The crimp tool has a ratchet which prevents premature opening of the crimp tool.

Part number.: **080.000.014.000.000**

Pin Gauge = Adjustment

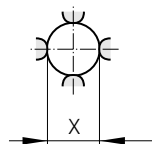

Adjustment for
8-Point Crimp Tool

Adjustment Table for 8-Point Crimp Tool

Dim. x	Cross Section
> 0,65 < 0,70	AWG 22
> 1,40 < 1,45	1,50 mm ²



Hexagonal Crimp Tool for termination cross section from 2,5 mm² with coupling system.

Part number for cross section 2,5 mm²: **080.000.012.000.000**



Hydraulic Hexagonal Crimp Tool for cross sections ≥ 10 mm² with safety valve which opens only if correct crimp pressure is reached.

Part number for crimp tool: **080.000.026.000.000**

Part number for crimp dies:
for cross section 10 mm²: **080.000.026.110.000**

For your notes

Section 3

Series 308, 309 and 310

Cylindrical Connectors with Bayonet Coupling
Neoprene Push-Pull Lock or Flange Mounting



Selected Technical Data

Positions:	2 - 90
Test Voltage:	to 3000 V AC
max. Single Contact Load:	to 500 A
Insulation Body and Contact Insert Material:	Duroplast, glass-filled, UL 94 V-0
Contacts:	Springtac™ sockets and solid pins
Contact Finish:	silver-plated and passivated
Housing Material:	Aluminum-alloy or Bronze, Ni-plated
Housing Finish:	painted or Ni-plated
Coupling Mechanism:	Bayonet, Neoprene push-pull, or flange mounting
Protection:	in mated and locked Condition up to IP 67

Type 308

60° Receptacle with Snap Cover for Bayonet Coupling
(mated and locked IP 55)

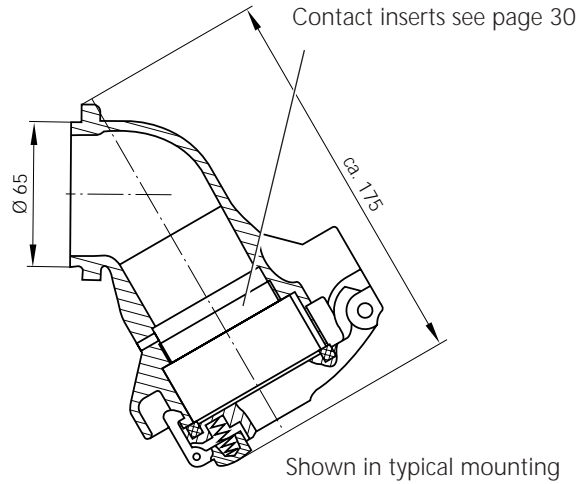

Part Number Alu-cast, painted	Part Number Bronze, Ni-plated	Comments
308.010.000.642.000	308.010.000.554.000	

Straight Plug with Push-Button Ratchet Lock and Bayonet Coupling

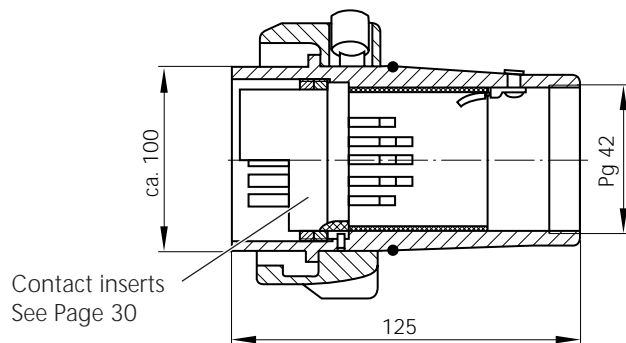

Part Number ¹⁾ Alu-cast, painted	Part Number ¹⁾ Bronze, Ni-plated	Comments
308.020.000.642.000	308.020.000.554.000	

Free Receptacle with Bayonet Coupling

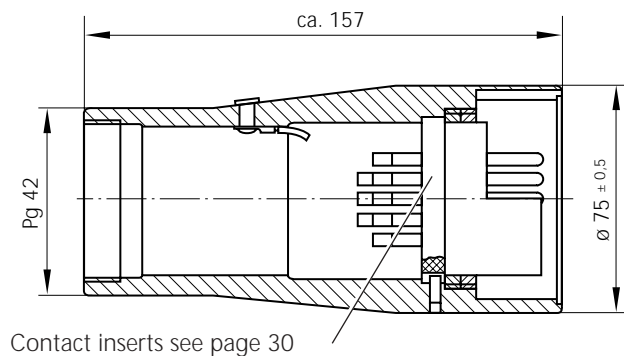

Part Number ¹⁾ Alu-cast, painted	Part Number ¹⁾ Bronze, Ni-plated	Comments
308.030.000.642.000	308.030.000.554.000	

¹⁾ Cable clamp is not included in part number (see page 45 and 46)
Assembly instructions see page 47

Type 308
Dummy Receptacle for Storage of Decoupled Plug

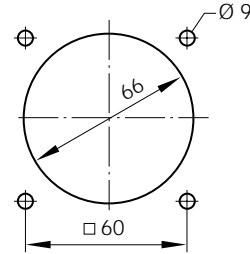

Part Number Alu-cast, painted	Part Number Bronze, Ni-plated	Comments
308.093.201.642.000	308.093.201.554.000	For Plug 308.020

Extension for Box-Mounting

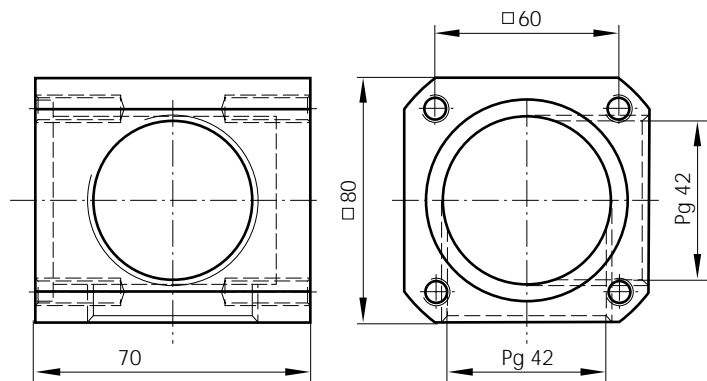

Part Number ¹⁾ Alu-cast, painted	Part Number ¹⁾ Bronze, Ni-plated	Comments
308.095.211.642.000	308.095.211.554.000	

Plastic Dust Cover



Part Number	Comments
308.097.001.926.000	For Plug (308.020) and In-Line Receptacle (308.030)

¹⁾ Cable clamp is not included in part number (see page 45 and 46)
Assembly instructions see page 47

Type 308
Inserts for Solder Contacts

	Pos.	Part Number	Contact Ø (mm)	Test Voltage VDE 0627	Single Contact Load (max.)	Term. Cross Section	Comments
	6+⏚	Socket Insert 308.705.150.007.000 Pin Insert 308.805.150.007.000	5,0	3000 V AC	80 A	10 mm ²	
	7+⏚	Socket Insert 308.703.150.008.000 Pin Insert 308.803.150.008.000	3,0	2250 V AC	40 A	2,5 mm ²	
	13+⏚	Socket Insert 308.705.150.014.000 Pin Insert 308.805.150.014.000	5,0	2250 V AC	80 A	10 mm ²	
	18+⏚	Socket Insert 308.704.150.019.000 Pin Insert 308.804.150.019.000	4,0	2250 V AC	50 A	6 mm ²	
	23+⏚	Socket Insert 308.703.150.024.000 Pin Insert 308.803.150.024.000	3,0	2250 V AC	40 A	2,5 mm ²	
	59+⏚	Socket Insert 308.702.150.060.000 Pin Insert 308.802.150.060.000	2,0	1750V AC	35 A	1,5 mm ²	

Additional contact inserts on request.

Contact finish silver-plated, other finishes on request.

⏚ = Ground, make first, break last

 = Additional information see Section 5 "Technical Information"

Type 309

Straight Receptacle with Snap Cover for Bayonet Coupling (mated and locked IP 55)

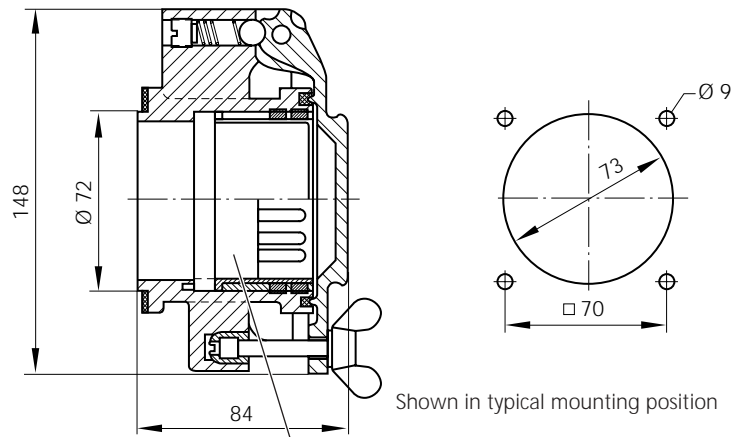

Contact inserts see page 37 - 39

Part Number Alu-cast, painted	Part Number Bronze, Ni-plated	Comments
309.010.000.642.000	309.010.000.554.000	

Straight Plug with Bayonet Coupling



Contact inserts see page 37 - 39

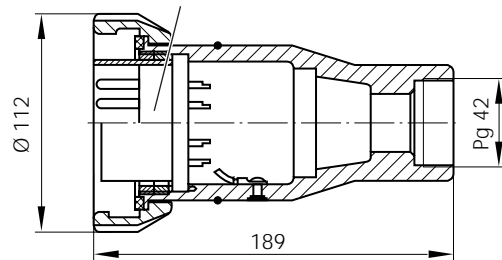

Part Number ¹⁾ Alu-cast, painted	Part Number ¹⁾ Bronze, Ni-plated	Comments
309.020.000.642.000	309.020.000.554.000	

Free Receptacle, Straight, Bayonet Coupling

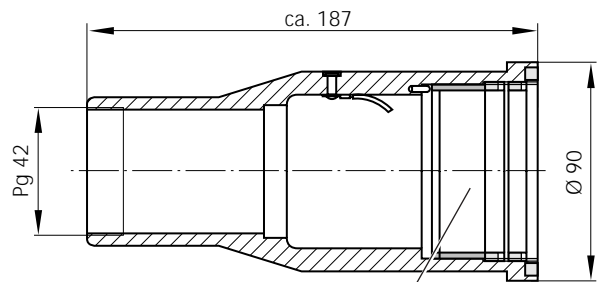

Contact inserts see page 37 - 39

Part Number ¹⁾ Alu-cast, painted	Part Number ¹⁾ Bronze, Ni-plated	Comments
309.030.000.642.000	309.030.000.554.000	

¹⁾ Cable clamp is not included in part number (see page 45 and 46)
Assembly instructions see page 47

Type 309

Straight Receptacle with Neoprene Snap-Lock (when mated and locked with plug below: IP 67, 1 bar/8 h)

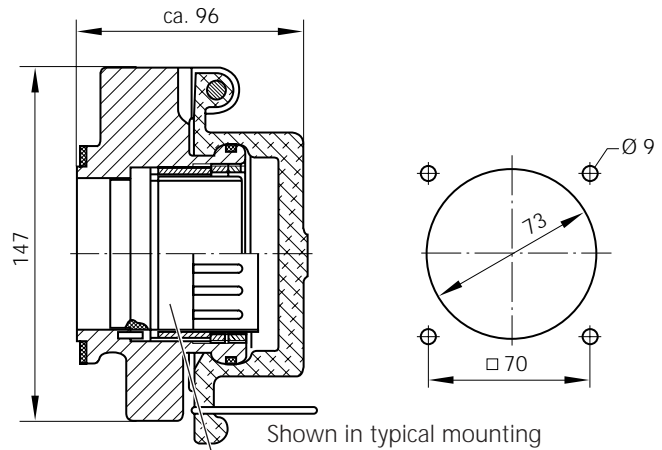

Contact inserts see page 37 - 39

Part Number Bronze, Ni-plated	Comments
309.012.000.554.000	with locked lid max 0,5 bar

Straight Plug with Neoprene Snap-Lock (when mated and locked IP 67, 1 bar/8 h)



Contact inserts see page 37 - 39

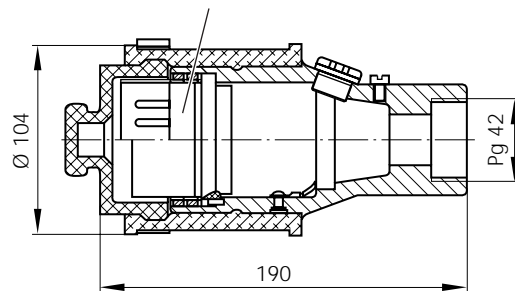

Part Number ¹⁾ Bronze, Ni-plated	Comments
309.021.000.554.000	with cable clamp 026 642... (see page 46)

Free Receptacle for Neoprene Snap-Lock (when mated and locked IP 67, 8 h)

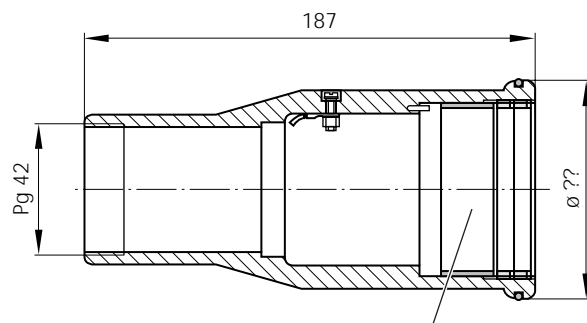

Contact inserts see page 37 - 39

Part Number ¹⁾ Bronze, Ni-plated	Comments
309.031.000.554.000	with cable clamp 026 642... (see page 46)

¹⁾ Cable clamp is not included in part number (see page 45 and 46)
Assembly instructions see page 47

Type 309

Straight Receptacle with Mounting Flange (when mated and locked IP 67, 3 bar / 8 h)



Contact inserts see page 37 - 39

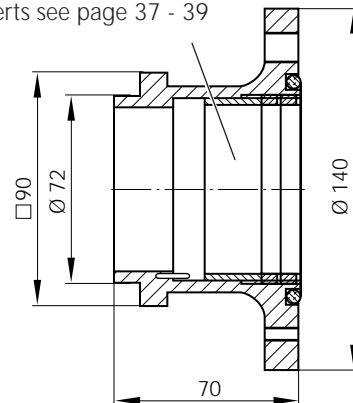

Part Number Alu-cast, painted	Part Number Bronze, Ni-plated	Comments
309.013.000.642.000	309.013.000.554.000	

Straight Plug with Mounting Flange (when mated and locked IP 67, 3 bar / 8 h)

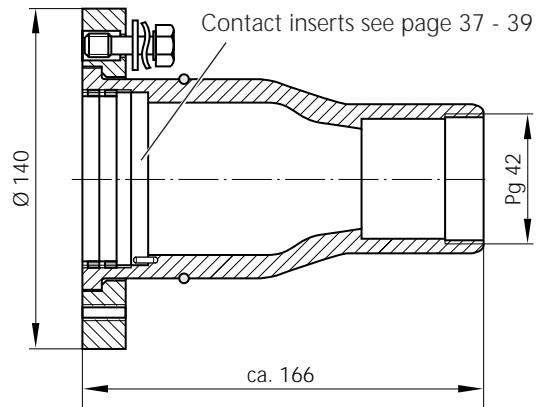

Part Number ¹⁾ Alu-cast, painted	Part Number ¹⁾ Bronze, Ni-plated	Comments
309.023.000.642.000	309.023.000.554.000	with cable clamp 026 642... (see page 46)

Free Receptacle, Straight, with Mounting Flange (when mated and locked IP 67, 3 bar / 8 h)

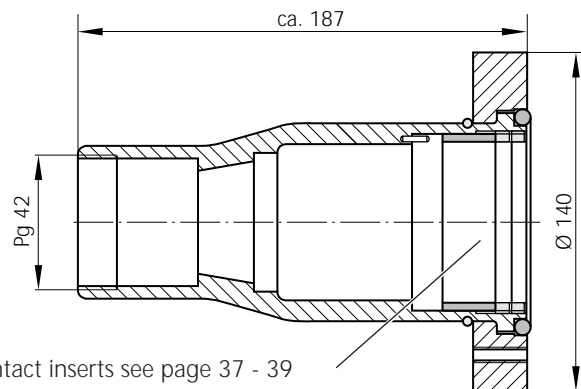

Contact inserts see page 37 - 39

Part Number ¹⁾ Alu-cast, painted	Part Number ¹⁾ Bronze, Ni-plated	Comments
309.033.000.642.000	309.033.000.554.000	with cable clamp 026 642... (see page 46)

¹⁾ Cable clamp is not included in part number (see page 45 and 46)
Assembly instructions see page 47

Type 309

Extension for Box Mounting

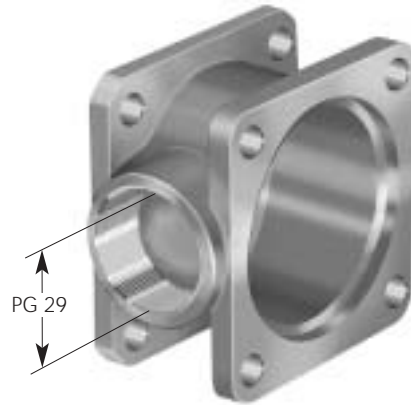

Part Number ¹⁾ Alu-cast, painted	Part Number ¹⁾ Bronze, Ni-plated	Comments
309.095.101.642.000	309.095.101.554.000	for Receptacle (309.010) and (309.012)

Dummy Receptacle for Storage of Decoupled Plug



Part Number Alu-cast, painted	Part Number Bronze, Ni-plated	Comments
309.093.100.642.000	309.093.100.554.000	for Plug (309.020)

Plug Cover



Part Number Cover of Alu-cast, painted	Part Number Cover of Bronze, Ni-plated	Comments
309.097.001.642.000	309.097.001.554.000	for Plug (309.020)

¹⁾ Cable clamp is not included in part number (see page 45 and 46)
Assembly instructions see page 47

Type 309
Cover for Free Receptacle



Part Number Cover of Alu-cast, painted	Part Number Cover of Bronze, Ni-plated	Comments
309.097.003.642.000	309.097.003.554.000	for Free Receptacle (309.030)

Plastic Cover for Plug



Part Number Cover (Plastic)	Comments
309.097.002.924.000	for Plug (309.021)

Quick Lock for Plug



Part Number	Comments
309.021.018.200.000	for Plug (309.021)

Type 309

Plastic Cover for Panel Receptacle and Free Receptacle



Part Number Cover (plastic)	Comments
309.097.005.926.000	for Receptacle (309.013) and Free Receptacle (309.033) with Flange

Plastic Cover for Plug



Part Number Cover (plastic)	Comments
309.097.004.926.000	for Plug with Mounting Flange (309.023)

Type 309
Inserts for Solder Contacts

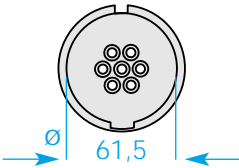
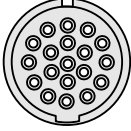
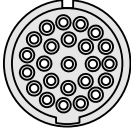
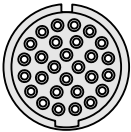
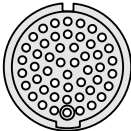
	Pos.	Part Number	Contact Ø (mm)	Test Voltage VDE 0627	Single Contact Load (max.)	Term. Cross Section.	Comments
	6+ ⊥	Socket Insert 309.703.150.007.000 Pin Insert 309.803.150.007.151	3,0	3000 V AC	40 A	2,5 mm ²	
	18+ ⊥	Socket Insert 309.703.150.019.000 Pin Insert 309.803.150.019.151	3,0	2250 V AC	40 A	2,5 mm ²	
	23+ ⊥	Socket Insert 309.703.150.024.000 Pin Insert 309.803.150.024.151	3,0	2250 V AC	40 A	2,5 mm ²	
	27+ ⊥	Socket Insert 309.703.150.028.000 Pin Insert 309.803.150.028.151	3,0	2250 V AC	40 A	2,5 mm ²	
	49+ ⊥	Socket Insulation Body 309.700.150.050.000 Pin Insulation body 309.800.150.050.151	2,0	2250 V AC	35 A	1,5 mm ²	

Additional contact inserts on request

Contact finish silver-plated, other finishes on request

⊥ = Ground, make first, break last

 = Additional information see Section 5 "Technical Information"

Type 309

Inserts for Contacts with Screw Termination for Series 309

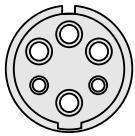
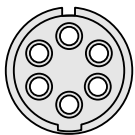
	Pos.	Part Number	Contact Ø (mm)	Test Voltage VDE 0627	Single Contact Load (max.)	Term. Cross Section.	Comments
	3+ ⚡ 2 Pi	Socket Insert 309.700.151.006.000	9,0 5,0	2250 V AC	145 A 50 A	25 mm ² 6 mm ²	
		Pin Insert 309.800.151.006.151					
	5+ ⚡	Socket Insert 309.705.153.006.000	5,0	2250 V AC	80 A	10 mm ²	
		Pin Insert 309.805.153.006.151					

Additional contact inserts on request

Contact finish silver-plated, other finishes on request

⚡ = Ground, make first, break last

Pi = Pilot contacts break last

 = Additional information see Section 5 "Technical Information"

Type 309
Insulation Bodies for Crimp Contacts

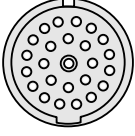
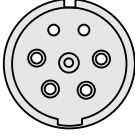
	Pos.	Part Number	Contact Ø (mm)	Test Voltage VDE 0627	Single Contact Load (max.)	Term. Cross Section.	Comments
	23+⊥	Socket Insert 309.703.151.024.000 Pin Insert 309.803.151.024.151	3,0	2250 V AC	40 A	2,5 mm ²	(Contacts included in Part-No.)
	3+⊥ 2 Pi	Socket Insert 309.700.150.006.000 Pin Insert 309.800.150.006.151	6,0 3,0	2250 V AC	110 A 40 A	16 mm ² 2,5 mm ²	(Contacts included in Part-No.)

Additional contact inserts on request

Contact finish silver-plated, other finishes on request

⊥ = Ground, make first, break last

Pi = Pilot contacts break last

 = Additional information see Section 5 "Technical Information"

Crimp Tools see page 48!

Type 310

Straight Receptacle with Snap Cover for Bayonet Coupling (mated and locked IP 55)

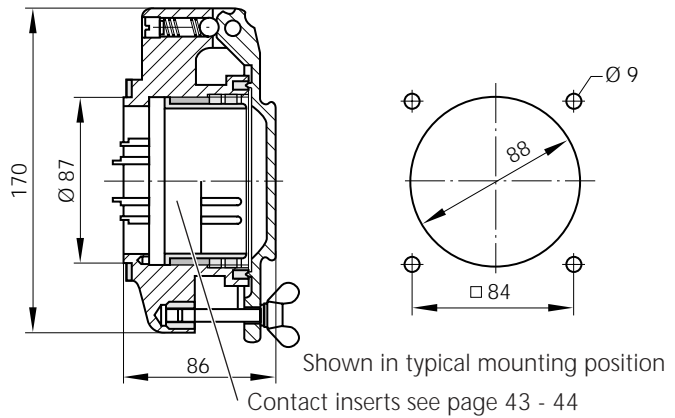

Part Number with Lock Screw Alu-cast, painted	Part Number* with Snap Lock Alu-cast, painted	Comments
310.010.000.642.000	310.011.000.642.000	

Right-Angle Receptacle for Bayonet Coupling (when mated and locked IP 55)

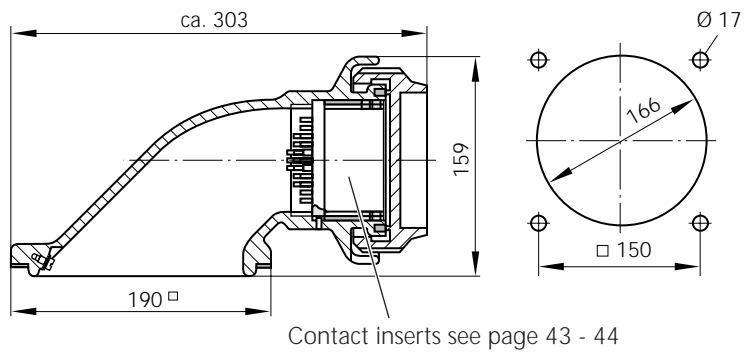

Part Number Alu-cast, painted	Comments
310.012.000.642.000	

60° Receptacle, with Snap Cover for Bayonet Coupling (when mated and locked IP 55 *)

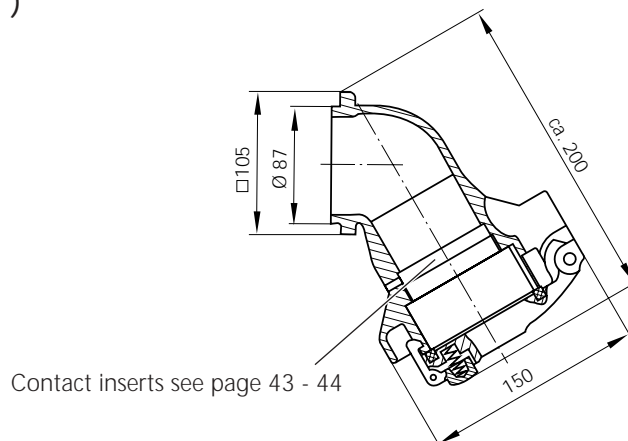

Part Number Alu-cast, painted	Comments
310.013.000.642.000	

* only for socket inserts (otherwise contact factory)

Assembly instructions see page 47

Type 310

Straight Plug with Bayonet Coupling (when mated and locked IP 55)

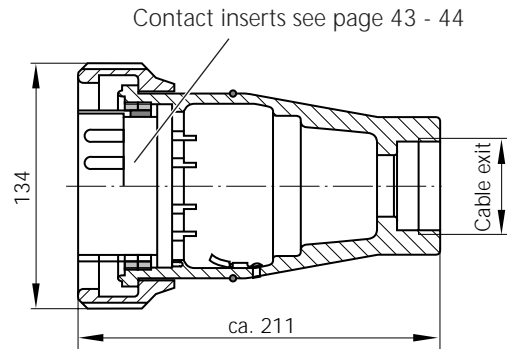

Part Number ¹⁾ Alu-cast, painted	Cable exit	Comments
310.020.000.642.000	Pg 42	
310.025.000.642.000	Pg 48	

**Straight Plug with Bayonet Coupling
(when mated and locked IP 55)**

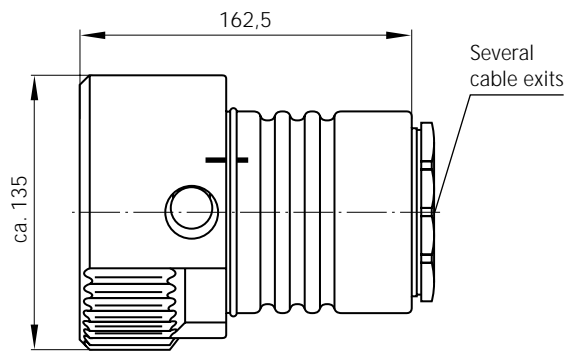

Contact inserts see page 43 - 44

Housing with cable exits for crimp inserts on page 44

Part Number ¹⁾ Alu-cast, painted	Cable Exits ¹⁾	Comments
310.221.000.642.000	Cable exit 4 x Pg 21; 1 x Pg 11	without ratchet lock
310.220.000.642.000	Pg 48	with ratchet lock
310.213.000.642.000	R 2 1/2 "	without ratchet lock

Free Receptacle, Straight, Bayonet Coupling (when mated and locked IP 55)

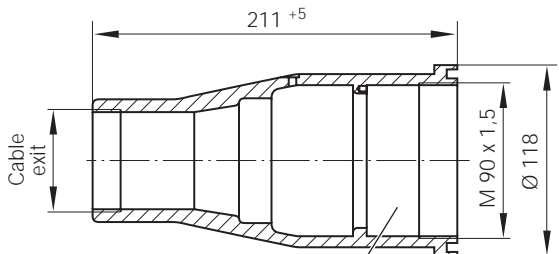

Contact inserts see page 43 - 44

Part Number ¹⁾ Alu-cast, painted	Cable exit	Comments
310.030.000.642.000	Pg 42	
310.035.000.642.000	Pg 48	

¹⁾ Cable clamp is not included in part number (see page 45 and 46) · Assembly instructions see page 47

Type 310

Extension for Box Mounting

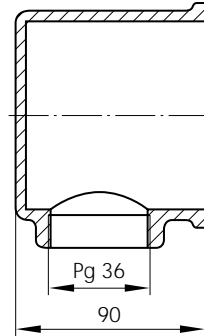
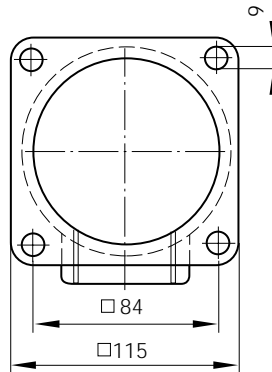

Part Number ¹⁾ Alu-cast, painted	Comments
310.095.101.642.000	for Receptacle (310.010) and (310.013)

Dummy Receptacle for Storage of Decoupled Plug



Part Number Alu-cast, painted	Comments
310.093.200.642.000	for Plug (310.020) and (310.2XX.)

Plug Cover



Part Number Alu-cast, painted	Comments
310.097.001.642.000	for Plug (310.020) and (310.2XX)

¹⁾ Cable clamp is not included in part number (see page 45 and 46)
Assembly instructions see page 47

Type 310
Inserts for Solder Contacts

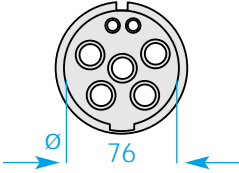
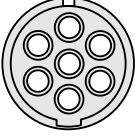
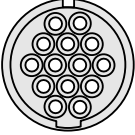
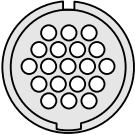
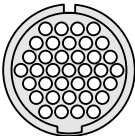
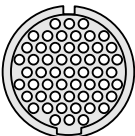
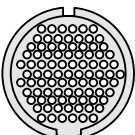
	Pos.	Part Number	Contact Ø (mm)	Test Voltage VDE 0627	Single Contact Load (max.)	Term. Cross Section	Comments
	4+⚡ 2 Pi	Socket Insert 310.714.151.005.000 Pin Insert 310.814.151.005.151	14,0	2250 V AC	275 A	70 mm ²	
	6+⚡	Socket Insert 310.710.150.007.000 Pin Insert 310.810.150.007.151	10,0	2250 V AC	175 A	35 mm ²	
	13+⚡	Socket Insert 310.709.150.014.000 Pin Insert 310.809.150.014.151	9,0	2250 V AC	145 A	25 mm ²	
	18+⚡	Socket Insert 310.706.150.019.000 Pin Insert 310.806.150.019.151	6,0	2250 V AC	110 A	16 mm ²	
	36+⚡	Socket Insert 310.705.150.037.000 Pin Insert 310.805.150.037.151	5,0	2250 V AC	80 A	10 mm ²	
	54+⚡	Socket Insert 310.703.150.055.000 Pin Insert 310.803.150.055.150	3,0	2250 V AC	40 A	2,5 mm ²	
	88 + 2 ⚡	Socket Insert 310.700.150.090.000 Pin Insert 310.800.150.090.150	2,3	2250 V AC	40 A	2,5 mm ²	

Additional contact inserts on request

Contact finish silver-plated, other finishes on request

⚡ = Ground, make first, break last

Pi = Pilot Contacts break last

 = Additional information see Section 5 "Technical Information"

Type 310

Insulation Bodies for Crimp Contacts

	Pos.	Part Number	Contact Ø (mm)	Test Voltage VDE 0627	Single Contact Load (max.) (Crimp-Contact)	Comments
	3+ ⊥ +2 Pi	Socket Insulation Body 310.718.001.004.000	18 4	2750 V AC	see below	2 Pilot Contacts Delivered without Contacts (see below)
		Pin Insulation body 310.818.001.004.151				

⊥ = Ground, first-make, last-break

■ = Additional information see Section 5 "Technical Information"

Crimp-Contacts

For Insulation Body:	Part Number Std. Contact	Part Number Grd. Contact	Term. Cross Section	Single Contact Load (max.)	Comments	
Socket 310.718.001.004.000	170.435.000.201.000	170.434.000.201.000	120 mm ²	365 A		
	170.437.000.201.000	170.436.000.201.000	95 mm ²	335 A		
	170.439.000.201.000	170.438.000.201.000	70 mm ²	275 A		
	170.441.000.201.000	170.440.000.201.000	50 mm ²	240 A		
	170.443.000.201.000	170.442.000.201.000	35 mm ²	175 A		
	170.445.000.201.000	170.444.000.201.000	25 mm ²	145 A		
	170.449.000.201.000	170.448.000.201.000	16 mm ²	110 A		
	Pilot Contact	170.430.000.201.000		1,5 mm ²	35 A	
Pin 310.818.001.004.151	180.435.000.301.000	180.435.000.301.000	120 mm ²	365 A		
	180.437.000.301.000	180.437.000.301.000	95 mm ²	335 A		
	180.439.000.301.000	180.439.000.301.000	70 mm ²	275 A		
	180.441.000.301.000	180.441.000.301.000	50 mm ²	240 A		
	180.443.000.301.000	180.443.000.301.000	35 mm ²	175 A		
	180.445.000.301.000	180.445.000.301.000	25 mm ²	145 A		
	180.449.000.301.000	180.449.000.301.000	16 mm ²	110 A		
	Pilot Contact	180.430.000.301.000		1,5 mm ²	35 A	

Contact finish: .201. and .301. = silver-plated, .207 and .307. = gold-plated

In Receptacle 310.013.000.642.000 only termination cross section 50 mm² possible.

Crimp Tools see page 48!

Series 308, 309 and 310 Cable Clamp and Strain Relief

The ODU-Cable clamps with strain relief are available for all connectors shown in this catalog.

When connecting cables to electrical equipment, tools or machines, it is imperative that an effective cable strain relief is provided in accordance with VDE and other local standards and regulations. The cable clamp assemblies with the strain relief shown in this catalog meet various VDE requirements and contribute to the functionality of the connector when used with electrical equipment.

Selected Technical Data and Features

Material:	Brass Ni-plated
Sealing:	Neoprene Gasket
Sizes:	Pg 16 to Pg 48 The cable clamp entry for each connector has the largest possible Pg size. The part number for the strain relief is composed of the Pg size and the cable outer diameter. It may be necessary to install the included reduction units to accommodate smaller cable diameters.

Cable Clamp with Strain Relief (Protection IP 55)



Cable Ø	Part Number Pg 29	Part Number Pg 36	Part Number Pg 42	Part Number Pg 48
12,0 - 21,0	026.429.120.210.000	026.436.120.210.000		
19,0 - 30,0	026.429.190.300.000	026.436.190.300.000	026.442.190.300.000	
25,0 - 37,0		026.436.250.370.000		026.448.250.370.000
31,0 - 42,0			026.442.310.420.000	
35,0 - 48,0				026.448.350.480.000

Series 308, 309 and 310
Cable Clamp with Strain Relief
and Cable Bending Protection Sleeve (IP 55)



Cable Ø	Part Number Pg 29	Part Number Pg 36	Part Number Pg 42	Part Number Pg 48
7,5 - 9,0	026.529.075.090.000			
9,0 - 11,0	026.529.090.110.000			
11,5 - 13,0	026.529.115.130.000	026.536.115.130.000		
13,5 - 15,0	026.529.135.150.000	026.536.135.150.000	026.542.135.150.000	
15,0 - 17,0	026.529.150.170.000	026.536.150.170.000		
17,0 - 19,0	026.529.170.190.000	026.536.170.190.000		
18,0 - 20,0	026.529.180.200.000	026.536.180.200.000	026.542.180.200.000	
21,0 - 23,0	026.529.210.230.000	026.536.210.230.000		
23,0 - 25,0	026.529.230.250.000	026.536.230.250.000		
23,0 - 26,0		026.536.230.260.000	026.542.230.260.000	026.548.230.260.000
27,0 - 30,0		026.536.270.300.000	026.542.270.300.000	026.548.270.300.000
30,0 - 33,0		026.536.300.330.000	026.542.300.330.000	026.548.300.330.000
32,0 - 35,0		026.536.320.350.000	026.542.320.350.000	026.548.320.350.000
35,0 - 38,0			026.542.350.380.000	026.548.350.380.000
36,0 - 40,0			026.542.360.400.000	026.548.360.400.000
40,0 - 44,0				026.548.400.440.000

Cable Clamp with Environmental Seal (Protection IP 68)

Water- and oil-tight cable clamp for wide range of temperatures
 from - 40 °C to + 125 °C



Cable Ø	Part Number Pg 29	Part Number Pg 36	Part Number Pg 42	Part Number Pg 48
7,0 - 15,0	026.629.070.150.000			
7,9 - 16,9				
11,9 - 21,9	026.629.119.219.000	026.636.119.219.000		
17,8 - 29,8	026.629.178.298.000	026.636.178.298.000	026.642.178.298.000	
25,0 - 39,0		026.636.250.390.000		026.648.250.390.000
29,2 - 45,2			026.642.292.452.000	
33,0 - 50,0				026.648.330.500.000

**Series 308, 309 and 310
Assembly Instructions**

Parts Description	
1	Receptacle Housing
2	Contacts
3	Socket Insert
4	Spacer Ring
5 - 8	Threaded Ring
9	Guide Ring (only for unprotected pins)
10	Pin Insert
11	Ground Cable
12	Plug Housing
13	Cable
14 - 23	Cable Clamp

 = order separately

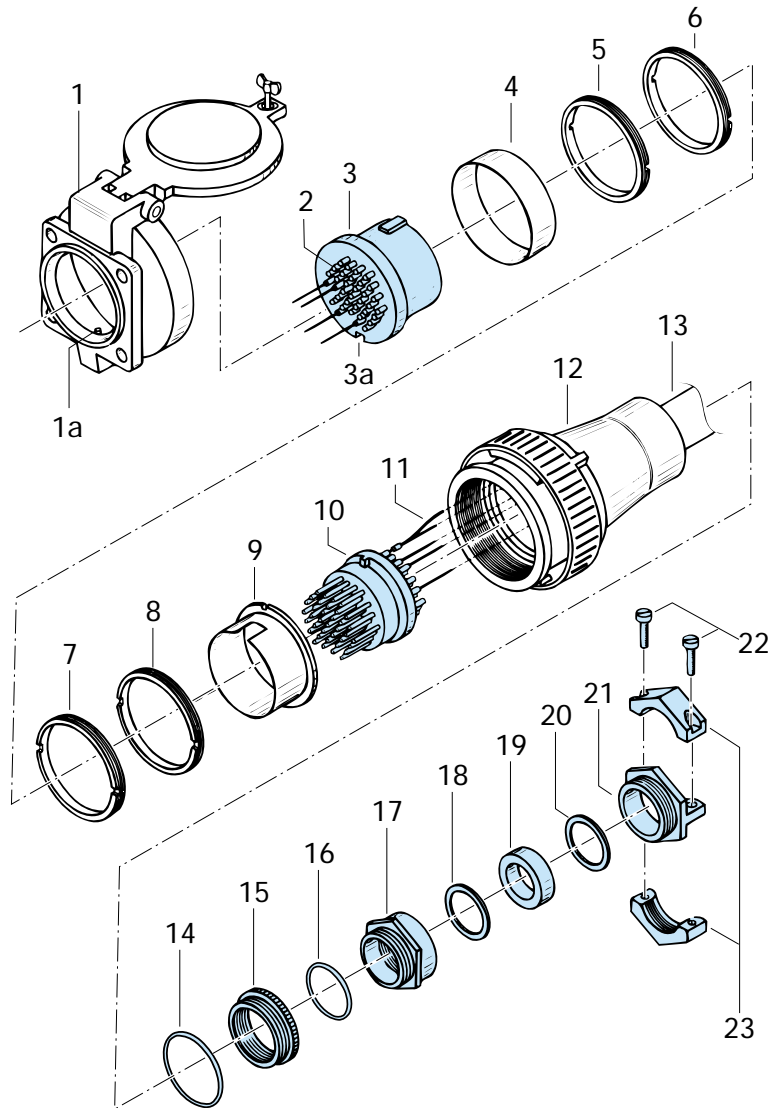
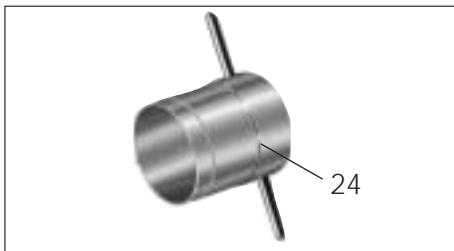

Assembly Tool

for Series 308, 309 and 310

for Series	Part Number for Assembly Key
308	308.098.001.719.000
309	309.098.000.719.000
310	310.098.001.719.000

Assembly of Receptacle

1. Push stripped conductors through receptacle (1).
2. Solder conductors to contacts (2).
3. Either socket or pin Insert (3) into Receptacle (1); important, Pin (1a) must snap into groovet (3a).
4. With Socket Insert spacer ring (4) must be used.
5. Fasten threaded ring (5, 6) with assembly tool.

Assembly of Plug

1. Push cable clamp (14 - 23) and plug housing (12) over Cable (13).
2. Connect ground strap (11) to ground cable (13).
3. Solder stripped conductors to contacts.
4. Mount either pin oder socket insert (10) into plug housing (12), important: Pin (1a) must snap into groovet (3a).
5. With pin Insert guide ring (9) on insert (10). Watch out for keying!
6. Fasten threaded ring (7,8) with assembly tool.
7. Connect cable clamp (14 to 23).

Instruction about blowtorch soldering > 6 mm²

During heat-stress it can come to a damage on the contact-elements on the insulating materials as well. (Limit temperature 120°C)

Remedy: Put the inserts into the water. (If possible, distilled water)

Attention! Warmed water at 35°C must be renewed.

After the solder process the connector has to be carefully dried .

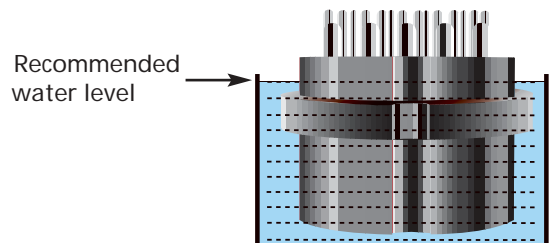

Series 309 and 310

Tools and Accessories

Crimp tools have a safety release which opens when the correct crimp pressure is reached. Premature opening of the crimp tool is thereby prevented.



Hexagonal Crimp Tool for termination cross section from 1,5 to 2,5 mm² with locking system.

Part number for cross section 1,5 mm² 080.000.021.000.000
 Part number for cross section 2,5 mm²: 080.000.012.000.000



Hydraulic Hexagonal Crimp Tool for cross sections 16 mm² – 120 mm² with safety valve which opens only if correct crimp pressure is reached.

Part-No. crimp tool: 080.000.017.000.000

Part-No. crimp dies:

For cable cross section	Part Number Crimp Dies
16 mm ²	921.000.005.000.002
25 mm ²	921.000.005.000.005
35 mm ²	921.000.005.000.006
50 mm ²	921.000.005.000.008
70 mm ²	921.000.005.000.009
95 mm ²	921.000.005.000.011
120 mm ²	921.000.005.000.013

Section 4 Special Connectors



Special connectors are connectors designed to meet application-specific requirements. They are based on the connectors shown in this catalog but have been customized to conform to specifications provided by our customers.

Offshore (Series OS)



For datacommunications between modules on off-shore platforms (living module, escape module, etc.)

Consists of:

- Ceramic inserts
- Ni-Cr-steel housing
- Special contacts

Ⓝ NEMKO
Cert./No.
Ex 92 C 011

Type 329
TV-Lighting Systems (Distribution)



Single-conductor connector in accordance with DIN 15 563 and 15 564 with bayonet coupling.

For connection of power, ground, and safety conductor in outdoor lighting systems.

Rail Roads

UIC Connectors with Lever-Action for Rail Road Coupling

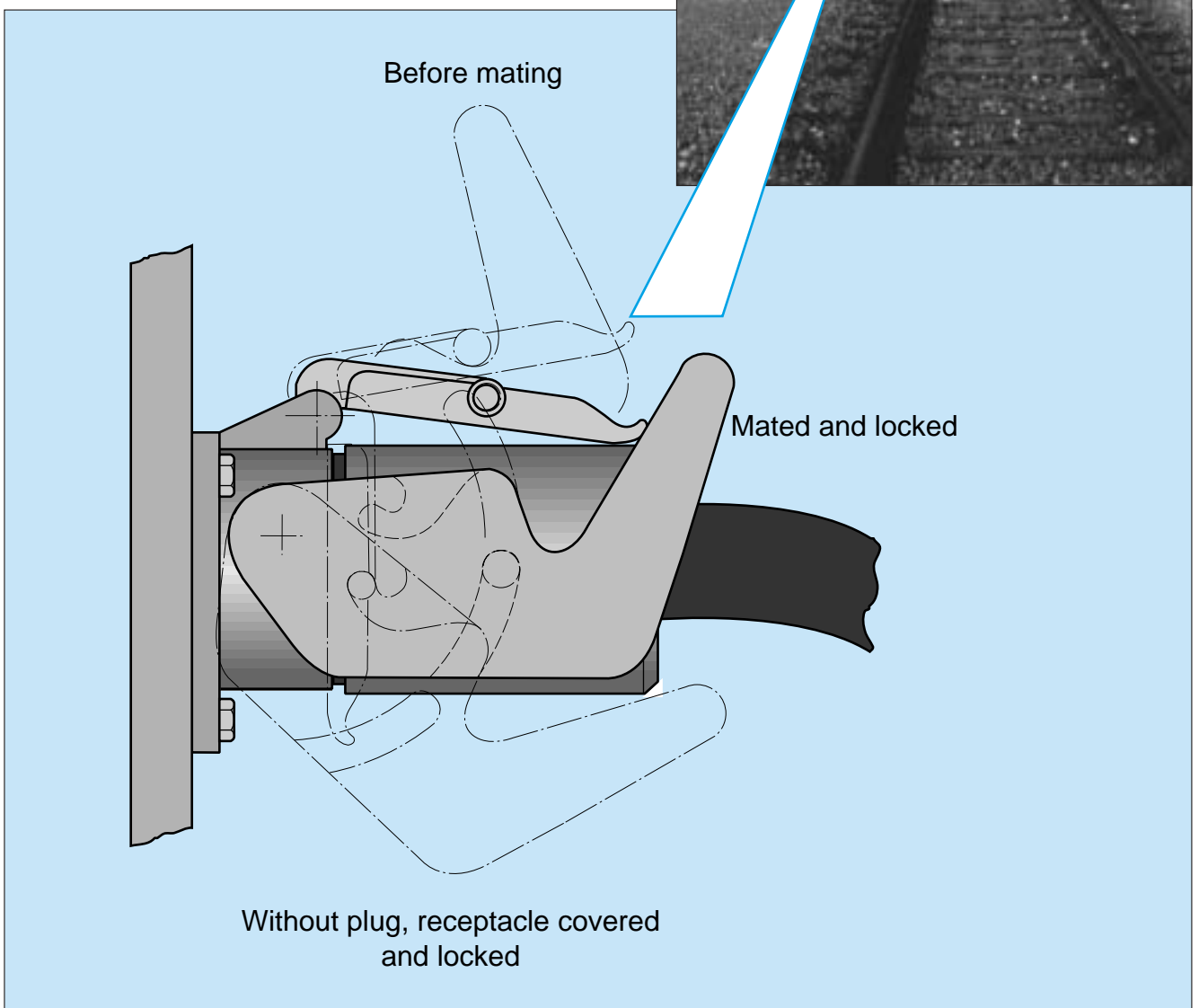
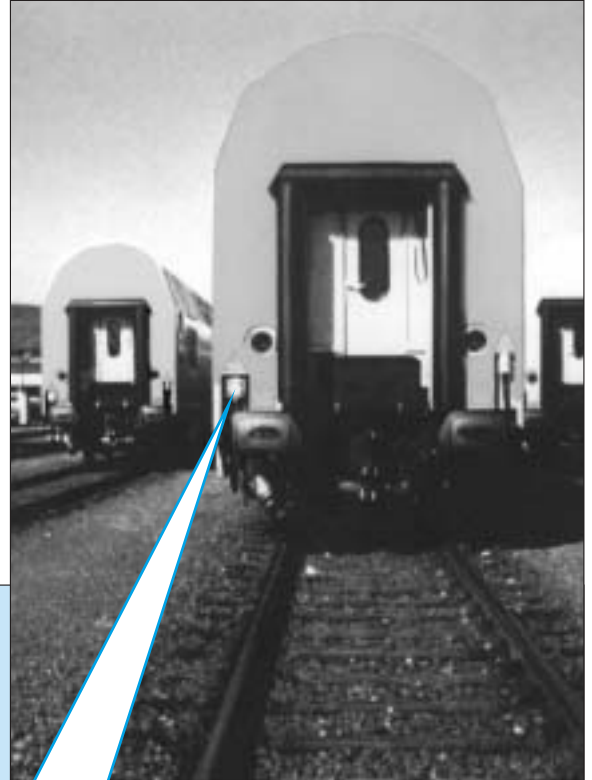

Steel industry

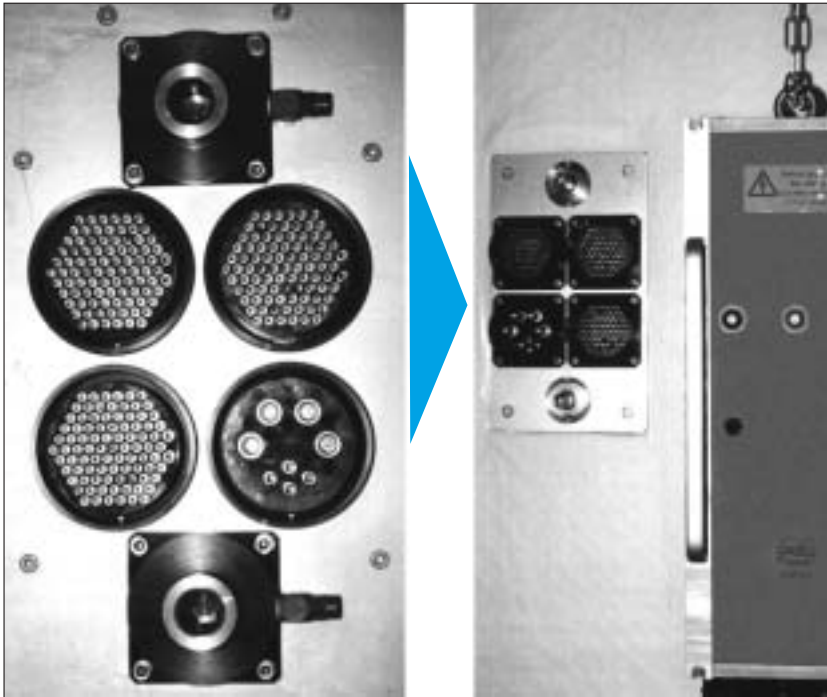

Docking system for steel mills. Has four connectors. Docking is performed pneumatically by pushing a push-button.



High-temperature connector for use on furnaces in steel mills.

Connectors are operated by personnel with heavy gloves.

Connector consists of:

- Ceramic inserts
- Steel housing
- Springwire contacts made from special alloys

Truck Connector



Water-tight connector (IP 65). Delivered with cable. Bayonet locking system. Used for datacommunications on tank vehicles.



Power distribution



Docking system for high-powered Na-S batteries. Connectors have signal and power contacts (300 A), cooling air and hot-air connections. All connectors are mounted floating to allow blind-mating.

Nuclear power plants

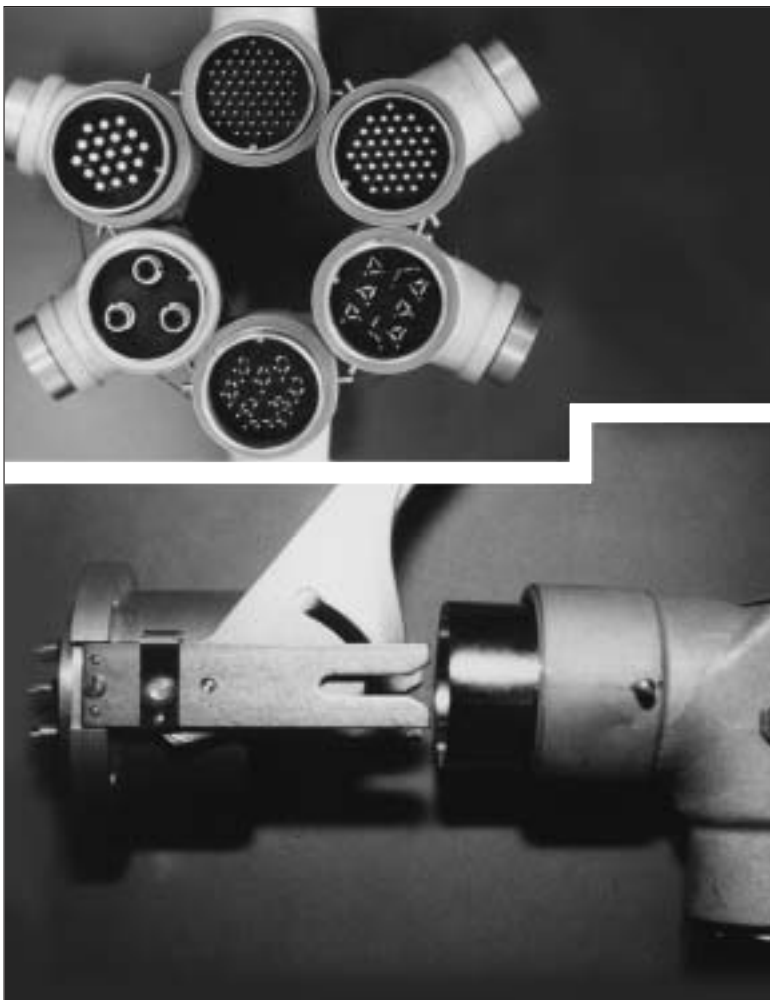

Special connectors for nuclear power plants.

Connection from reactor to core.
Operated by hand or manipulator.

Nuclear Power Plants, Robotic Loading and Testing



ODU-MAC in double-DIN housing. Used on loading robots in nuclear power plants for control and data-communications.

Housing is cut from solid aluminum blocks.

Standard inserts from ODU-MAC family. Up to 680 contact positions.

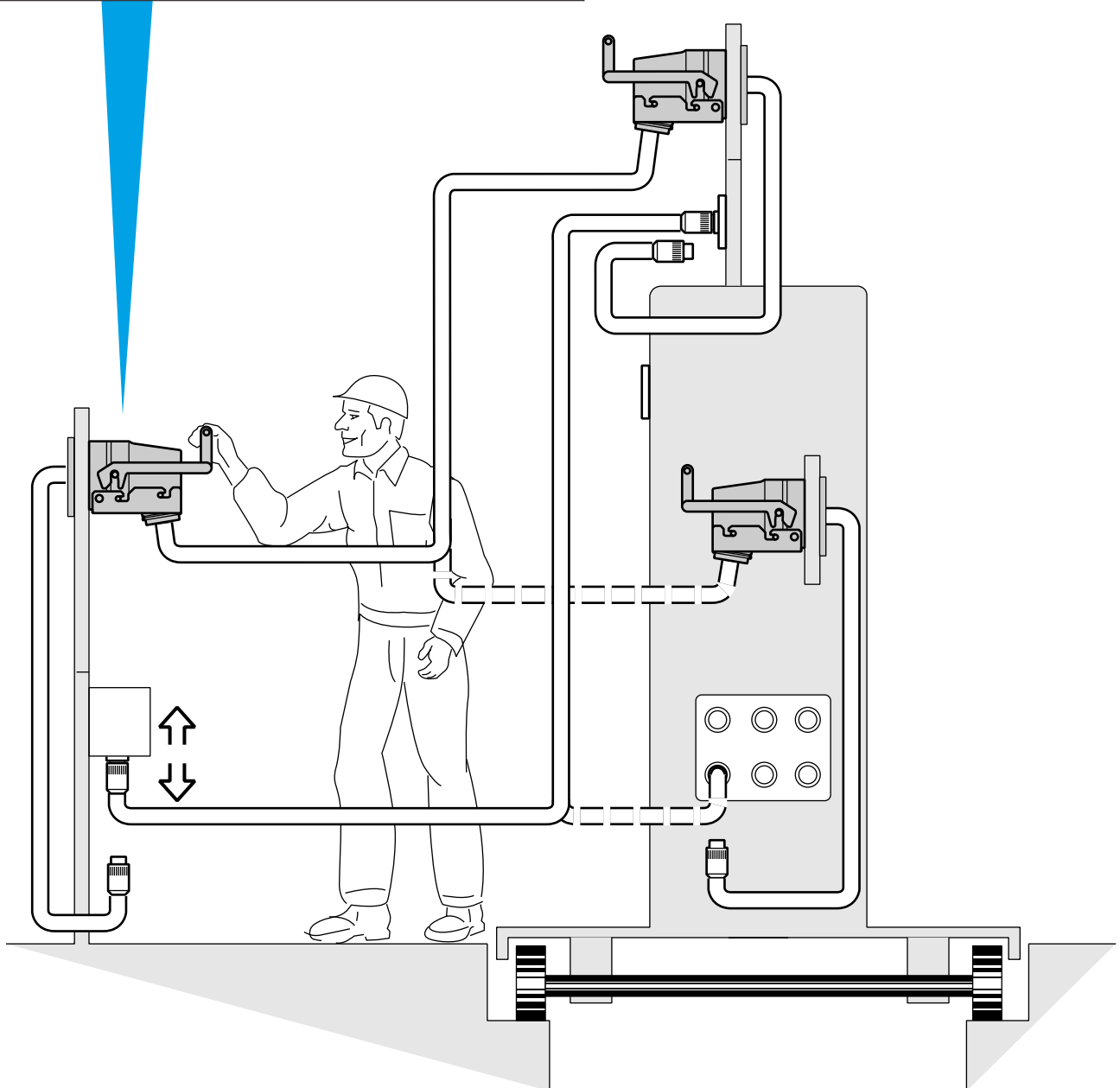

For your notes:

Section 5

Technical Information for the User

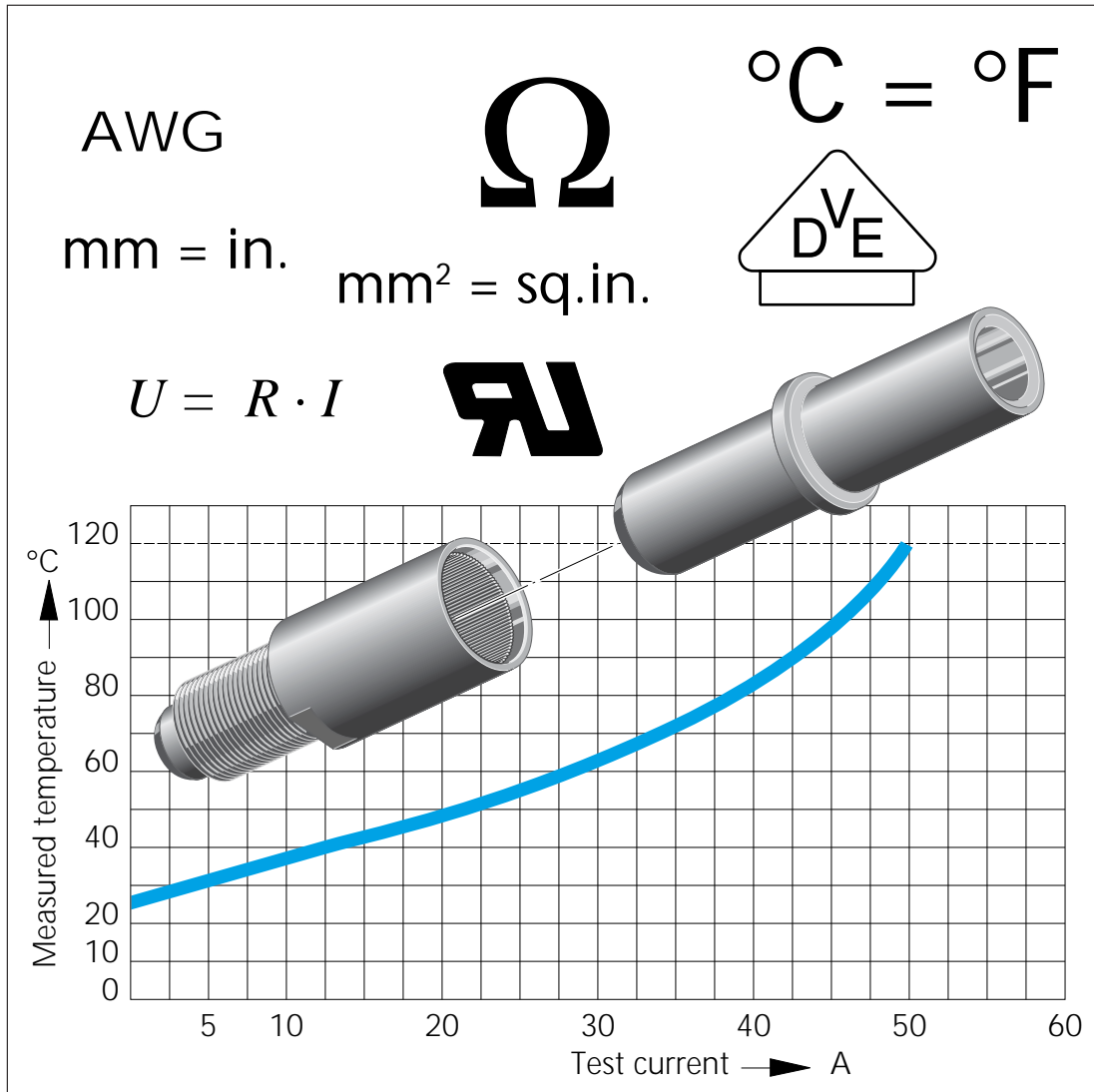

Table of Contents

	Page
Environmental Protection (IP) in accordance with DIN 40 050	58
Insulation Groups / Nominal Voltage / Test Voltage	60
Current Load	61
Derating Factors	62
Current Load for ODU Springtac™ Contacts	65
Materials	69
Glossary of Terms	70
Conversion Tables	71
Conductance and Resistance for DC Current	72

Technical Information - Protection Classes acc. to DIN 40 050

Protection is described with a code consisting of two letters (**IP**) and two numbers.

IP : International **P**rotection

The complete code, the letters IP and the two numbers, defines the protection class.

Example of Protection Class:

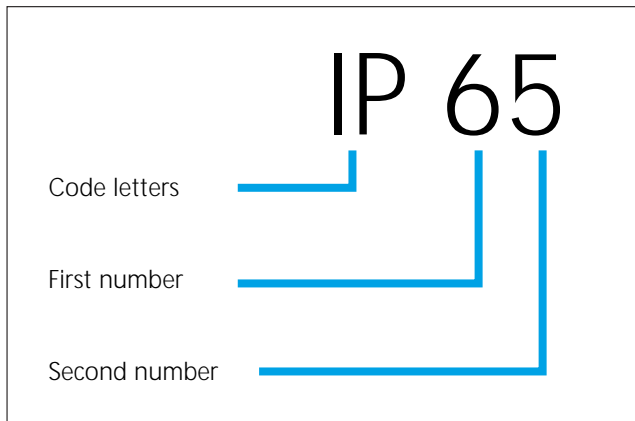

Definitions:

Letter code IP Stands for International Protection

First number: Protection against accidental touch and intrusion of foreign particles.

Second number: Protected against intrusion of water.

Technical Information / Protection Classes

Protection against touch and foreign materials

First Number	Degree of Protection
0 No protection	No protection against accidental touch of parts under power or moving or stationary parts.
1 Protected against large foreign particles	Protection against accidental touch of parts under power in large areas or internal moving parts. Protected against intrusion of particles larger than 50 mm diameter.
2 Protected against medium-sized foreign particles	Protection against accidental touch with fingers of parts under power or moving internal parts. Protected against intrusion of particles larger than 12 mm diameter.
3 Protected against small foreign particles	Protection against accidental touch of parts under power or internal moving parts with tools, wires or similar products with thickness of larger than 2.5 mm. Protected against intrusion of particles with diameter larger than 2.5 mm.
4 Protected against grain-sized foreign particles	Protection against accidental touch of parts under power or internal moving parts with tools, wires or similar products with thickness of larger than 1mm. Protected against intrusion of particles with diameter larger than 1mm.
5 Protected against dust deposition	Complete protection against accidental touch of parts under power or internal moving parts. Protected against detrimental dust deposition. Intrusion of dust is not completely prevented, but dust can not be deposited in such quantity that performance is reduced.
6 Protected against dust intrusion	Complete protection against accidental touch of parts under power or internal moving parts. Complete protection against dust.

Protection against intrusion of water

Second Number	Degree of Protection
0 No protection	No special protection.
1 Protected against vertical drops of water	Water drops falling vertically have no effect.
2 Protected against oblique falling water drops	Water drops, falling in an angle of no more than 15° from vertical, have no negative effect.
3 Protected against splash	Water, falling in an angle of no more than 60° from vertical have no negative effect.
4 Protected against spray water	Water spray from all directions has no negative effect.
5 Protected against water jet	Water jet from all directions has no negative effect.
6 Protected against flooding	Water has no effect during temporarily flooding, such as in heavy seas.
7 Protected while temporarily submerged	Water can not penetrate for a defined length and depths of submersion.
8 Protected while permanently submerged	Water can not penetrate for an indefinite length and at defined depths of submersion.

Technical Information - Insulation Classes Nominal Voltage - Test Voltage

Insulation Classes in accordance with DIN VDE 0100

Classification of connectors based on environmental operating conditions.

Example :

A connector used in a machine shop falls into Class B. A connector used in a laboratory would fall into Class A

Insulation Class A0 :

For low power equipment used in climate-controlled and dry rooms with only minimal heat increase when subjected to short circuit conditions.

Insulation Class A :

For equipment used in climate-controlled and dry rooms.

Insulation Class B :

For equipment used in living quarters, offices and other commercial rooms. In precision machine shops, laboratories, test stands, and medical environments.

Insulation Class C :

For equipment primarily used in industrial, commercial, and agricultural establishments. Non climate-controlled warehouses, workshops, heating facilities, and manufacturing plants.

Insulation Class D :

For equipment on vehicles subjected to break dust and splash water or snow and not protected by any housings.

Determination of Nominal Voltage from Test Voltage in accordance with VDE 0627

The following explains how to arrive at the nominal voltage when using the test voltage. Operating voltage can not be more than nominal voltage.

Please see pages 70 and 71 for definitions in accordance with DIN.

Example :

The selected connector has a test voltage of 1,000 V and is to be used in a precision tool shop. (Insulation Class B)
According to the table below the connector can be operated at a nominal voltage of 150VDC. The example is shown in **bold** in the table.

Table 3 : From DIN VDE 0627

Nominal Voltage in Volt		Test Voltage in Volt (AC 50 Hz)				
DC Voltage in Volt (DC)	AC Voltage in Volt (AC)	Insulation Class				
		A0	A	B	C	D
15	12	375	500	750	875	1250
36	30	500	500	750	1000	1500
75	60	500	625	875	1000	1500
150	125	625	750	1000	1250	1750
300	250	750	875	1250	1750	2250
450	380	875	1000	1750	2250	3000
600	500	1000	1250	2000	2750	3500
800	660	1250	1750	2500	3500	4000
900	750	1500	1750	2750	3500	4500
1200	1000	1750	2250	3500	4500	5500

Technical Information - Current Load

Current load for ODU Springtac™ contacts is shown on pages 65 through 68. Contact diameters are from 0.7 mm to 22 mm. All contacts must have the correct mating contact pin.

The following example explains how to use the diagrams.

Springtac™ Socket Type 170-....
with solid pin Type 180...
Contact Material: Brass, silver-plated
Contact Ø 1mm 1 mm² Cross Section

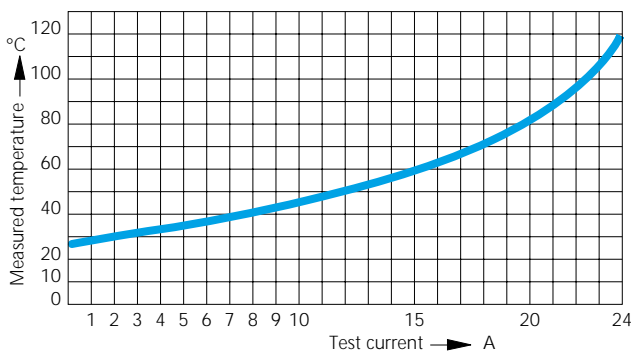

Springtac™ Socket Type 170-....
with solid pin Type 180...
Contact Material: Brass, silver-plated
Contact Ø 14 mm 150 mm² Cross Section

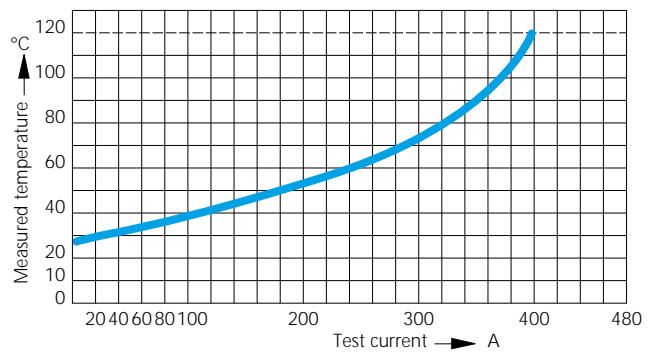

Both diagrams show contact temperature vs. test current. Contact temperature consists of ambient temperature (here 23° C) and temperature rise due to the current load. Current load curves end at 120° C contact temperature since this is the max. operating temperature for standard Springtac™ sockets. The company does make high-temp contacts for 500° C and higher.

In practical application most contacts operated in multi-position connectors. To determine the maximum current load per contact for a multi-position connector requires the use of a **derating factor**. In addition, many applications do not permit contact temperature of 120° C. It is equally important to consider the ambient temperature and the cross section of the conductor (cable).

All considerations are discussed in examples 1 through 4 on the following pages (see page 65).

Technical Information - Derating Factor

Current load values given in the connector and contact specifications in previous sections are single contact current loads.

Multi-position connectors heat faster than single contacts. It is therefore necessary to apply a derating factor to calculate the maximum current load per contact in multi-pole connectors. There is no precise specification for connectors. In practice, one uses the derating factor from DIN 57 298 Part 2 and VDE 0298 Part 2 for multi-conductor cable. (Ref. DIN 41 640, Part 3).

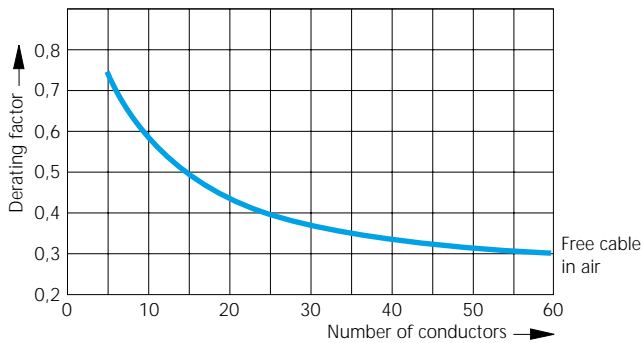

Load Derating Factor plastic jacketed cable in air from 1,5 - 10 mm² cross section.

Derating Factor
Multi-conductor cable with cross section 1.5 mm² to 10 mm² in air.

Number of Conductors	in Air
5	0,75
7	0,65
10	0,55
14	0,50
19	0,45
24	0,40
40	0,35
61	0,30

Example:

The cable has 24 conductors with a cross section of 6 mm² each.

From the diagram the derating factor is determined as 0.4

A single copper conductor with 6 mm² cross section can carry a load of 44 A. Therefore, a cable with 24 conductors of each having a 6 mm² cross section can carry maximum 17.6 A per conductor (44 A x 0.4 = 17.6 A)

Technical Information / Application examples

Example 1: Termination Cross Section

A 3 mm diameter contact has a termination cross section of 6 mm². If the user terminates the contact to a cable with only a 2.5 mm² cross section, then the cable and not the contact determines the maximum current load. To determine the maximum current load for the smaller cable select a contact with the same cross section. For example:

Contact diameter 3 mm with 6 mm² termination cross section
max. single contact current load = 50 A

Contact diameter 3 mm with 2.5 mm² termination cross section
max. single contact current load = 40 A (to be safe use the next smaller contact in table on page 65, which is 2 mm diameter)

Technical Information - Application Examples

Example 2: Multi-Position Connector with Reduced Cable Cross Section

Required: 90 A continuous
4 positions, solder contacts
cable cross section 16 mm² .

Desired: Smallest possible connector with threaded coupling .

See Section 2, Type 209, page 19:

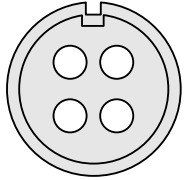
	Pos.	Part Number	Contact Ø (mm)	Test Voltage VDE 0627	Single Contact Current Load	Term. Cross	Comments
	3+⊥	Socket Insert 209.708.150.004.108	8,0	1750 V AC	145 A	25 mm ²	
		Pin Insert 209.808.150.004.150					

A 8 mm diameter contact with 25 mm² termination cross section is suitable for 145 A current load. Since the cable cross section is only 16 mm² we have to select a smaller contact. The 5 mm diameter contact with 16 mm² cross section has maximum current load of 110 A.

Result: The Type 209 with above shown contact insert is suitable and has enough current load reserves.

Example 3: Derating Factor for Multi-Position Connector

Required: 17 A continuous
7 positions, crimp contacts
cable cross section 1.5 mm² .

Desired: Smallest possible connector with threaded coupling .

See Section 2, Type 209, page 16:

	Pos	Part Number	Contact Ø (mm)	Test Voltage VDE 0627	Single Contact Current Load (max).	Comments
	6+⊥	Socket Insulation Body 207.702.001.007.000	2,0	1250 V AC	35 A	without contacts (see below)
		Pin Insulation Body 207.802.001.007.150				

Insulation Body:	Part Number Standard Contact	Part Number Ground Contact	Term. Cross Section	Part Number Dummy Contact	Removal Tool Crimp Tool
Socket 207.702.001.007.000	170.381.000.201.000	170.381.000.201.000	1,5 mm ²	021.341.135.924.000	087.170.364.000.000
Pin 207.802.001.007.150	180.332.000.301.000	180.333.000.301.000	1,5 mm ²	021.341.135.924.000	080.000.014.000.000

The selected contacts are 2 mm diameter with 1.5 mm² crimp termination. Max. single current load is 35 A.

Since the connector has 7 contacts, a derating factor has to be used. From the table on page 62 the derating factor is determined to be 0.6. Maximum current load per contact in the seven-conductor connector is 0.6 x 35 A = 21 A.

Result: The selected connector is suitable for the application (only 17 A requested).

Technical Information - Application Examples

Example 4: Multi-Position Connector in Higher Ambient Temperature

Required: 19 A continuous
 4 positions, solder contacts
 cable cross section 2.5 mm²
 ambient temperature 40° C

Desired: Smallest possible connector with threaded coupling .

See Section 2, Type 207, page 15:

	Pos.	Part Number	Contact Ø (mm)	Test Voltage VDE 0627	Single Contact Current Load	Term. Cross	Comments
	3+ $\frac{1}{2}$	Socket Insert 207.702.150.004.000	2,0	1750 V AC	40 A	2,5 mm ²	
		Pin Insert 207.802.150.004.150					

Single contact current load for this connector is 40 A. At 40 A the contact will have a temperature rise of 97° C to a contact temperature of 120° C. (From table on page 65 for a 2 mm diameter contact.)

The ambient temperature is 40° C and not 23° C. The current load curve is shifted upward by the temperature difference. Maximum current load is now 36 A and not 40 A.

Result: The selected connector is suitable for the application.

Springtac™ socket Type 170 ...
 Solid contact pin Type 180...
 Material: brass, silver-plated

Contact-Ø 2 mm 2,5 mm² Cross section

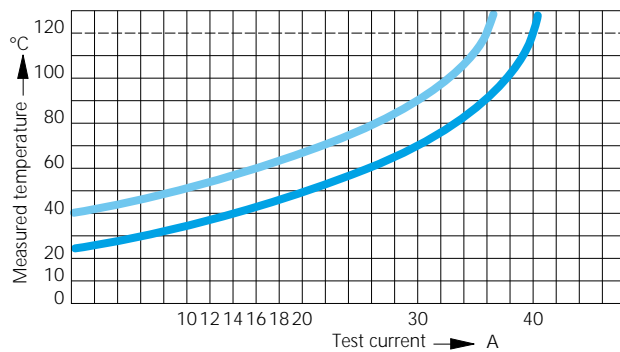

General Comments:

Upper temperature limit is given by the manufacturer. For ODU contacts the upper temperature limit is max. least 120° C. All components and parts of the ODU connectors can operate at that temperature.

This catalog shows mostly standard connectors. For higher operating temperature please contact the factory. Special materials can be used to extend the upper temperature limit.

For example, a special connector for off-shore application can operate up to 1000° C!

Special contacts with Ni-plated contact surfaces.

Standard ODU contacts have silver-plated finish. For special applications where corrosion is of concern Ni-plated contacts can be supplied. **For such contacts the maximum current load must be reduced by 25%.**

Current Load for ODU Contacts

Springtac™ sockets with correct solid contact pin (Table shows **Summary** of all single contact diagrams pages 66 through

Contact Material, Brass, Silver-plated
(For Ni-plated contacts current load must be reduced by 25%)

max. Conductor Cross Section

DIN VDE 0627

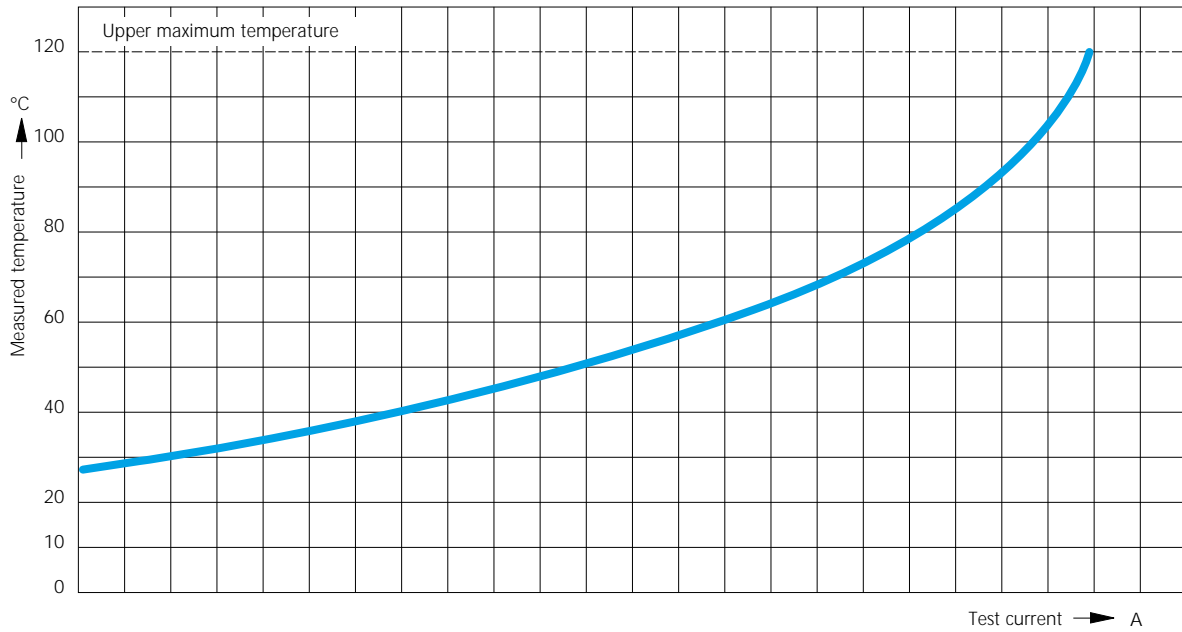

Contact Ø

Contact Ø	1	4	6	8	10	12	15	20	24
Ø 1									
Ø 1.5		5		10		15		20	35
Ø 2			10		15		25	30	40
Ø 3		5	10		20	22.5	30	40	50
Ø 4		10	20		30	40	50	60	80
Ø 5		20	40		60		80	100	110
Ø 6		20	40	60	80	100	120	145	
Ø 7		10	40	80	100	120	140	175	
Ø 8		10	30	50	100		150	210	
Ø 9		30	50	70	100	130	150	180	240
Ø10		25	50	75	100	150	200	275	
Ø12			50	75	100	150	200	300	340
Ø14		50	100		200		300	400	
Ø16		100	200		300		400	460	
Ø18		100	200	300	400		500	520	
Ø20		100	200	300	400	500	600	600	
Ø22		100	200	300	400	500	600	660	
Ø24		100	200	300	400	500	600	710	
Ø26		100	200	300	400	500	600	710	
Ø28		100	300	500	700		840		
Ø30		200	400	600	800		950		
Ø36		200	400	600	800	1000	1200		

Current Load for ODU Contacts

Contact material brass, silver-plated. Ni-plated 25% derating factor. Test procedure acc. VDE 0627

Springtac™ Socket Type 170-...
Solid pin Type 180-...
Contact Material Brass, silver-plated
Contact-Ø 0.76 mm 38/23 mm² Cable Cross Section

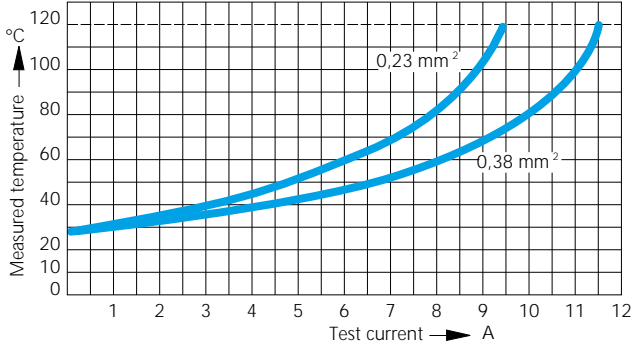

Springtac™ Socket Type 170-...
Solid pin Type 180-...
Contact Material Brass, silver-plated
Contact-Ø 1 mm 1 mm² Cable Cross Section

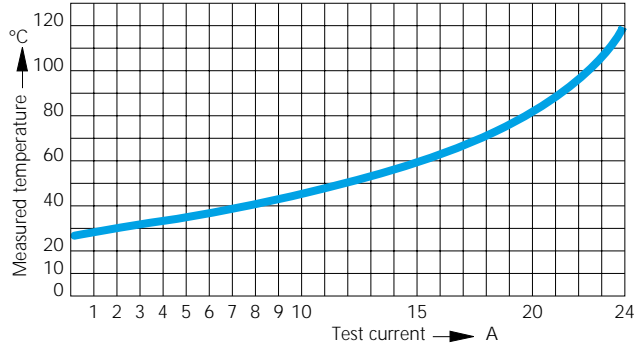

Springtac™ Socket Type 170-...
Solid pin Type 180-...
Contact Material Brass, silver-plated
Contact-Ø 1.5 mm 1.5 mm² Cable Cross Section

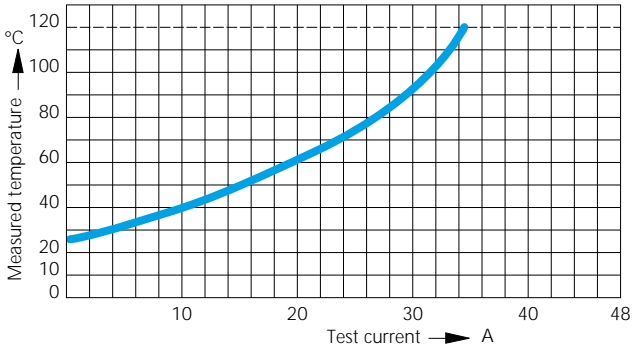

Springtac™ Socket Type 170-...
Solid pin Type 180-...
Contact Material Brass, silver-plated
Contact-Ø 2 mm 2.5 mm² Cable Cross Section

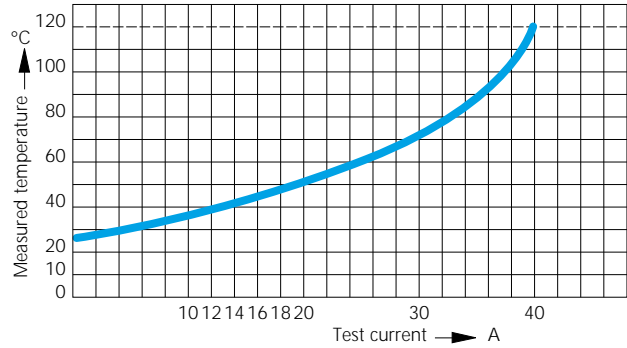

Springtac™ Socket Type 170-...
Solid pin Type 180-...
Contact Material Brass, silver-plated
Contact-Ø 3 mm 6 mm² Cable Cross Section

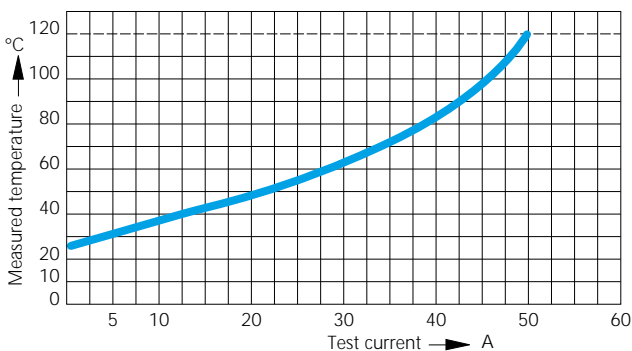

Springtac™ Socket Type 170-...
Solid pin Type 180-...
Contact Material Brass, silver-plated
Contact-Ø 4 mm 10 mm² Cable Cross Section

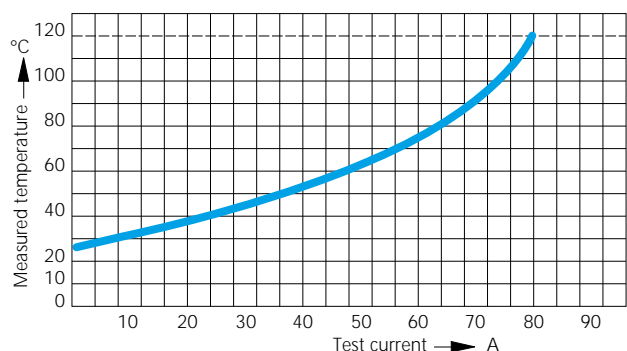

Current Load for ODU Contacts

Contact material brass, silver-plated. Ni-plated 25% derating factor. Test procedure acc. VDE 0627

Springtac™ Socket Type 170-...
Solid pin Type 180-...
Contact Material Brass, silver-plated
Contact-Ø 5 mm 16 mm² Cable Cross Section

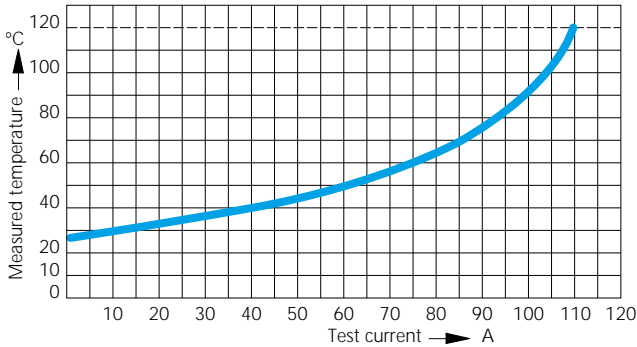

Springtac™ Socket Type 170-...
Solid pin Type 180-...
Contact Material Brass, silver-plated
Contact-Ø 6 mm 25 mm² Cable Cross Section

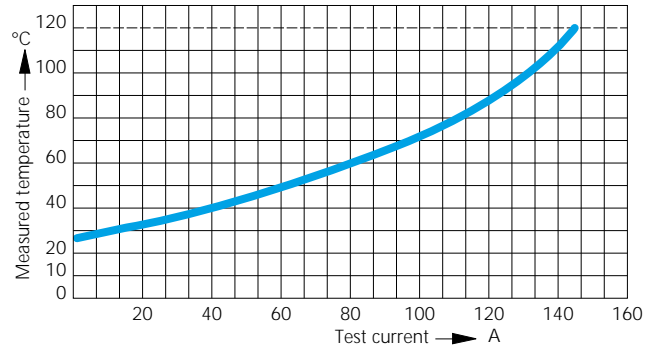

Springtac™ Socket Type 170-...
Solid pin Type 180-...
Contact Material Brass, silver-plated
Contact-Ø 7 mm 35 mm² Cable Cross Section

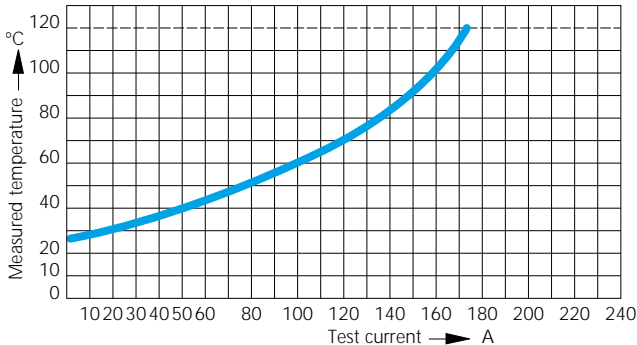

Springtac™ Socket Type 170-...
Solid pin Type 180-...
Contact Material Brass, silver-plated
Contact-Ø 8 mm 50 mm² Cable Cross Section

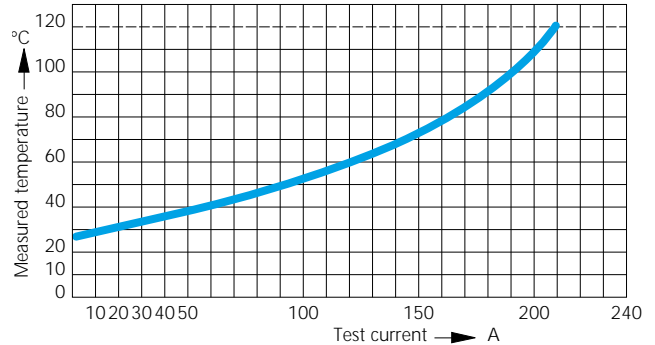

Springtac™ Socket Type 170-...
Solid pin Type 180-...
Contact Material Brass, silver-plated
Contact-Ø 9 mm 50 mm² Cable Cross Section

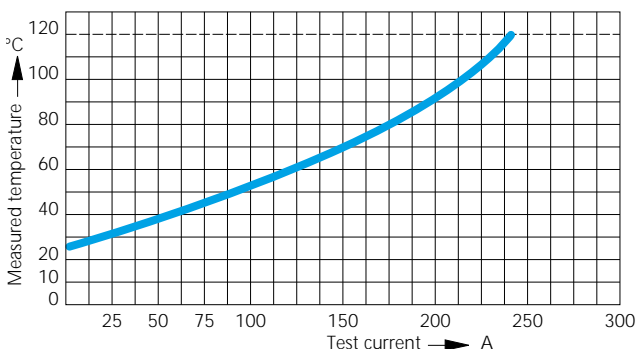

Springtac™ Socket Type 170-...
Solid pin Type 180-...
Contact Material Brass, silver-plated
Contact-Ø 10 mm 70 mm² Cable Cross Section

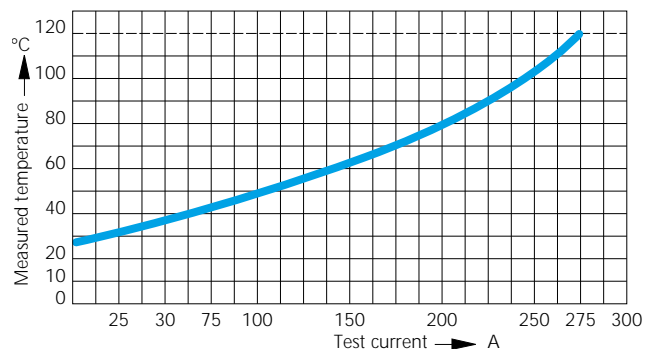

Current Load for ODU Contacts

Contact material brass, silver-plated. Ni-plated 25% derating factor. Test procedure acc. VDE 0627

Springtac™ Socket Type 170-...
Solid pin Type 180-...
Contact Material Brass, silver-plated

Contact-Ø 12 mm 95 mm² Cable Cross Section

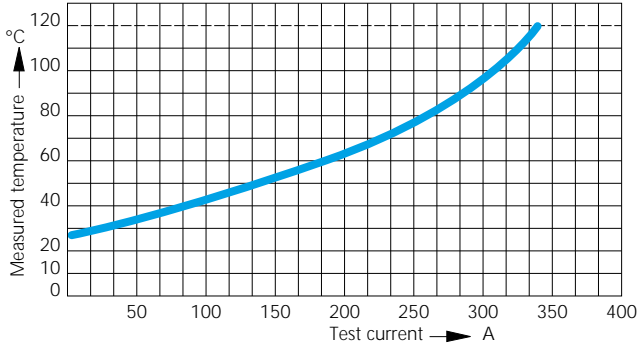

Springtac™ Socket Type 170-...
Solid pin Type 180-...
Contact Material Brass, silver-plated

Contact-Ø 14 mm 150 mm² Cable Cross Section

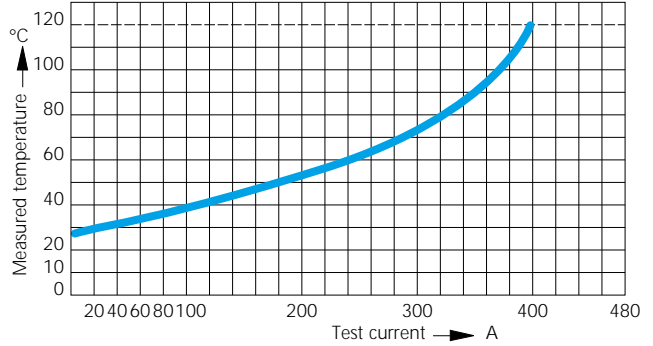

Springtac™ Socket Type 170-...
Solid pin Type 180-...
Contact Material Brass, silver-plated

Contact-Ø 16 mm 185 mm² Cable Cross Section

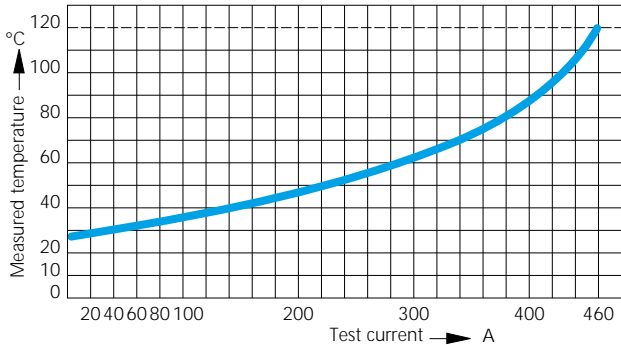

Springtac™ Socket Type 170-...
Solid pin Type 180-...
Contact Material Brass, silver-plated

Contact-Ø 18 mm 240 mm² Cable Cross Section

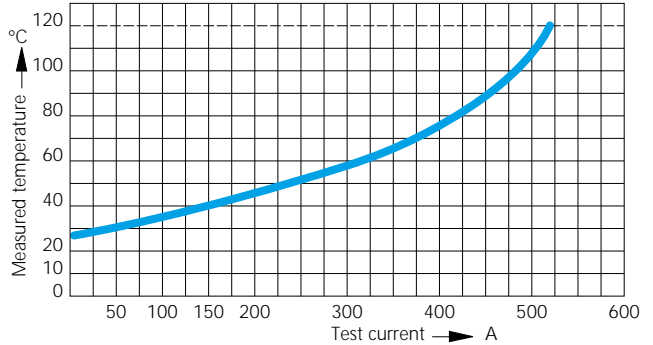

Springtac™ Socket Type 170-...
Solid pin Type 180-...
Contact Material Brass, silver-plated

Contact-Ø 20 mm 300 mm² Cable Cross Section

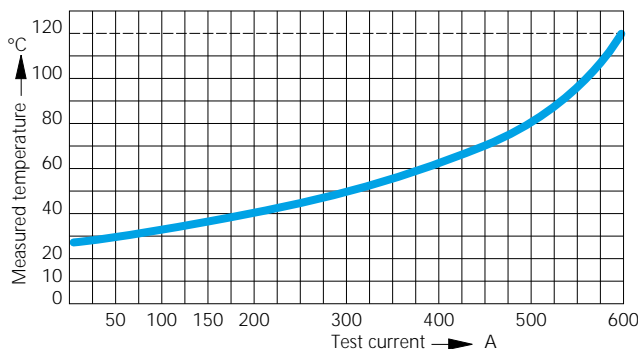

Springtac™ Socket Type 170-...
Solid pin Type 180-...
Contact Material Brass, silver-plated

Contact-Ø 22 mm 300 mm² Cable Cross Section

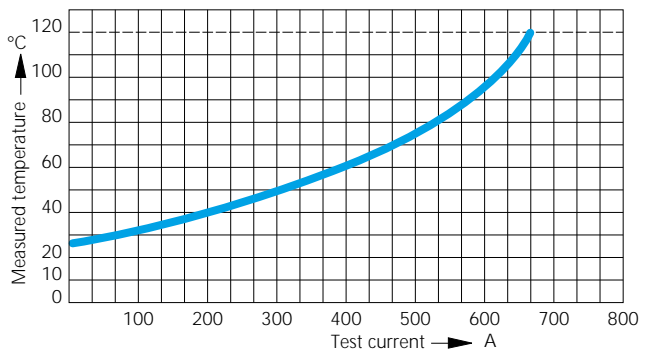

Technical Information - Materials

Housings:

Housings are made of aluminum alloys, brass, or sea water resistant bronze. Special materials are available.

Contact inserts and insulation bodies: (Standard)

	Contact Inserts für Threaded- and Solder	Insulation Bodies für Crimp Termination
Series 207, 208, and 209	Duroplast, glass-filled, UL 94 V-0	Thermoplast, glass-filled, UL 94 V-0
Series 308, 309 and 310	Duroplast, glass-filled, UL 94 V-0	Duroplast, glass-filled, UL 94 V-0
Special	Thermoplast, glass-filled, UL 94 V-0	Thermoplast, glass-filled, UL 94 V-0
	Duroplast, glass-filled, UL 94 V-0	Duroplast, glass-filled, UL 94 V-0
	Glimmer	Glimmer
	Ceramic	Ceramic
	Glass	Glass
	Special materials	Special materials

Special versions are available on request!

Thermoset (Duroplast)

Duroplast (also known as Duromere) is a thermoset material. Thermosets can be molded into permanent shape and harden under heat and pressure. Once the material has hardened, the part becomes infusible, generally insoluble, dimensionally stable, and has a very hard, impervious surface. Under the effects of heat and pressure, the material's molecules cross-link and form a three-dimensional network, which produces a rigid structure, resulting in less creep and cold flow than most thermoplastics (see below).

Thermosets have one transition temperature, which serves as their maximum short-term use temperature. There is no melting temperature because thermosets do not melt. Thermosets have high heat and chemical resistance, low shrinkage, are brittle, and are non-burning or self-extinguishing. Thermosets can not be welded.

Thermoplastics (Thermoplast)

Thermoplast is a thermoplastic. In contrast to thermosets, thermoplastics do not undergo chemical change in molecular alignment and can be reshaped. They become firm on cooling and harden into the mold configuration. As a class, these materials exhibit better electrical properties, more vivid and distinct colors, lighter weight and the ability to be extruded in thinner walls, when compared with thermosets. Thermoplastics are usually processed by injection molding, extrusion, blow molding and thermoforming.

Contacts

For threaded stud and solder termination

- Pins: brass, silver-plated.
- Socket: brass, silver-plated, springs silver-plated

For crimp termination

- Pins: brass, silver-plated.
- Socket: brass, silver-plated, springs silver-plated

or

- Pins: brass, silver-plated.
- Sockets: brass, gold-plated, springs gold-plated.

} Standard version

The catalog contains the part numbers for standard version.

Technical Information - Glossary of Terms

Connector

Used generally to describe all devices that provide connection or disconnection for printed circuit boards, electrical cable, and wire termination.

Free Connectors

Free connectors are connected to the free ends of cables.

Fixed Connectors

Fixed connectors are mounted on panels and equipment.

Upper Temperature Limit

The upper temperature limit defines the temperature at which a connector is still safe to operate. It is a sum of the ambient temperature and temperature rise due to current load.

Lower temperature Limit

Lowest temperature at which it is safe to operate the connector.

Mating Cycles

Mating cycles are the number of matings or connections between the contact socket and contact pin.

Insulation Body

Part of the connector. Has cavities for the contacts.

Creep Distance

Shortest distance on the surface between two voltage-carrying parts. Includes all hills and valleys along the surface. Must be within a minimum distance.

Air Distance

Shortest distance in air between two voltage-carrying metal parts.

Test Voltage

Test voltage defines the maximum voltage at which a connector has no insulation break down or spark-over.

Insulation Class

Insulation Class divides the connectors into groups according to ambient and operating conditions. (Also see Insulation Classes acc. to DIN VDE 0100).

Reference Voltage

Reference voltage is published in standards and insulation classes.

Nominal Voltage

Nominal voltage is supplied by the manufacturer and defines the operating conditions at which current loads are determined.

Technical Information - Glossary of Terms

Operating Voltage

Operating voltage is the supply voltage of the device which powers the system.

Single Contact Current Load

Current load for a single contact

Maximum Current Load

Maximum current load is the current a **connector** can carry on all contacts without exceeding the **upper operating temperature**.

Technical Information - Conversions

The world-wide application of **ODU** products makes it necessary to provide technical information in metric as well as British units. Wire sizes and termination cross sections need to be defined in mm, mm² and AWG (American Wire Gauge).

AWG = American Wire Gauge

Conductor Cross Section	Conductor Diameter (mm)	AWG
0,031	0,20	32
0,049	0,25	30
0,09	0,33	28
0,13	0,41	26
0,20	0,51	24
0,32	0,64	22
0,52	0,81	20
0,82	1,02	18
1,33	1,30	16
2,09	1,63	14
3,33	2,06	12
5,27	2,59	10
8,30	3,25	8
13,30	4,11	6
21,10	5,18	4
33,50	6,53	2
53,60	8,26	0

Values can deviate depending on the various cable designs.

Conversion Equations:

Length : Millimeter (mm) x 0,039 = Inches (in.)
(100 mm x 0,039 = 3,9 in.)

Inches (in.) x 25,4 = Millimeter (mm)
(10 in. x 25,4 = 254 mm)

Cross Section : mm² x 0,00155 = Square in.
(5 mm² x 0,00155 = 0,008 sq.in.)

Square inches (sq.in.) x 645 = mm²
(0,01 sq.in. x 645 = 6,45 mm²)

Weight : Gram (g) x 0,035 = Ounces (oz.)
(100 g x 0,035 = 3,5 oz.)

Kilogram (kg) x 2,205 = Pounds (lb.)
(2 kg x 2,205 = 4,41 lb.)

Ounces (oz.) x 28,35 = Gram (g)
(10 oz. x 28,35 = 283,5 g)

Pounds (lb.) x 0,454 = Kilogram (kg)
(10 lb. x 0,454 = 4,54 kg)

Temperature : (°C x 9/5) + 32 = Degree Fahrenheit (°F)

40 °C: 40 x 9/5 = 72

72 + 32 = 104 °F

104 °F: 104 - 32 = 72

72 x 5/9 = 40 °C

Technical Information - Conductance and Resistance

DC Current

Ohm's Law:

Describes the relationship between voltage (E) resistance (R) and current (I) in solid or liquid conductors.

$$E = R \cdot I$$

The proportionality constant R is called electric resistance, and is measured in Ohm (Ω). The reciprocal of R is called conductance *G*

$$G = 1/R$$

Resistance

Depends on material and dimension of conductor.

In cylindrical conductors: $R = \rho \cdot l/q = l/(q \cdot \sigma)$

ρ specific resistance in $\Omega \text{ mm}^2/\text{m}$,

$\gamma = 1/\rho$ conductance,

l length of conductor in m,

q conductor cross section in mm^2 ,

R_{ϑ} resistance at ϑ °C

R_{20} resistance at 20 °C

ϑ temperature coefficient in 1/K (= 1/°C),

Temperature in °C

Specific Resistance at 20 °C

(Defined as the resistance of a 1 m long conductor with 1 mm^2 cross section at 20° C.)

The **average** temperature coefficient α is defined at a temperature between 0° and 100° C. Specific resistance at *t* °C (other than 20° C) is:

$$\rho_t = \rho_{20} [1 + \alpha (t - 20 \text{ °C})].$$

1 $\Omega \text{ mm}^2/\text{m} = 1 \mu\Omega \text{ m}$. 1 S m/ $\text{mm}^2 = 1 \text{MS}/\text{m}$ (S = Siemens)

Material	Spec. electric resistance ρ $\mu\Omega\text{m}$	Electric conductance $\gamma = 1/\rho$ MS/m	Average temperature coefficient. $\alpha \times 10^{-3}$ 1/°C	Upper application temperature approx. °C
Aluminum, Al 99,5 (soft)	0,0286	35	3,8	–
Bronze CuBe 0,5, hardened	0,04 ... 0,05	20 ... 25	–	300
Gold (fine)	0,022	45	4	–
Copper, soft	0,01754	57	3,9	–
Brass CuZn 39 Pb 3	0,0667	15	2,33	–
Brass CuZn 20	0,0525	19	1,60	–
Nickel Ni 99,6	0,095	10,5	5,5	–
Silver (fine)	0,015	66,5	4,056	–
Tin	0,114	8,82	4,4	–

TELEFAX

Fax USA: (805) 484-7458
Fax UK: (0116) 230 1977

Fax Europe: (08631) 615649

From:

Company:	_____
Name:	_____
Division:	_____
Street:	_____
City, State, ZIP Code:	_____
Tel:	Fax: _____

Checklist for your Inquiry

Technical:

- Application: _____

- Special Considerations (for example environment, aggressive fluids, etc).

- Number of Positions: _____
- Current Load: a) Continuous _____ A
b) Short-term _____ A min,

- Operating Voltage: _____ V AC or DC
- Termination Cross Section: _____ mm² _____ AWG
- Cable Diameter _____ mm
- Ambient Temperature: _____ °C
- Connection: Cable-Cable
 Panel-Cable (straight plug)
 Panel-Cable (90° plug)

Commercial Data

- Anticipated annual requirement: _____ units
- First units required: _____ weeks
- Target price (unit) _____ US\$ DM other

For your notes:

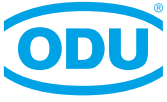

ODU's headquarters and factory are located in Mühldorf, at the river Inn, approximately 50 miles east of Munich, at the foothills of the Bavarian Alps.



Photo of City Mühldorf/Inn



Mühldorf, an idyllic small town with its typical Inn-Salzach architecture.



Steckverbindungssysteme

ODU-Steckverbindungssysteme GmbH & Co. KG
Otto Dunkel GmbH

Pregelstraße 11 · D-84453 Mühldorf/Inn
Telefon +49/86 31/61 56-0
Fax +49/86 31/61 56 49
Internet: <http://www.odu.de>
E-Mail: zentral@odu.de

ODU France
Téléphone: 01.39.35.46.90
Télécopie: 01.39.35.46.91
E-Mail:
odu.france@wanadoo.fr

ODU USA Inc.
Tel. 805.484.0540
Fax 805.484.7458
E-Mail:
raifeb@odu-usa.com
<http://www.odu-usa.com>

ODU-UK Ltd.
Tel. 01509 266 433
Fax 01509 266 777
E-Mail:
oduuk@globalnet.co.uk

ODU (Shanghai) Int. Trading Co. Ltd
Tel. +86/21-50 815 774
Fax +86/21-50 815 668
E-Mail:
adamjin@public2sta.net.cn

ODU Scandinavia AB
Tel. +46/176-1 82 61
Fax +46/176-1 82 62
E-Mail:
peter.biloch@odu.se

ODU (Shanghai) Connectors Manufacturing Co. Ltd
Tel. +86/21-50 815 774
Fax +86/21-50 815 668
E-Mail:
adamjin@public2sta.net.cn