



ODU MAC

Modular Connector System with
High Power, Signal, Coaxial and
fiber optic contacts, pneumatic modules



The latest version of this catalogue
is posted on our websites:
www.odu.de
and
www.odu-usa.com

UL-File E110586

All dimensions in mm.
All figures are illustrations or photos.
Changes reserved

Contents	Page
ODU MAC Product Description	4
ODU-Springwire Contact Principle	5
ODU MAC Modules: Insulation Bodies, Contacts, Technical Data	8 - 29
ODU MAC Aluminum Frame	30 - 34
ODU MAC DIN Housing	35 - 45
ODU MAC Crimp Tools	46 - 55
Technical Information	56 - 59
ODU MAC Application Examples	60 - 63
Technical Article	64 - 71

Product description:

The ODU MAC connector system consists of a variety of customizable rugged frames, plastic insulation bodies (modules) with many of insert patterns, and crimpable, removable contacts for high currents (power), low currents (signal), and RF-signals. Modules can be arranged in different patterns in the frame according to application. Unit spacing is 2.54 mm (.100") or a multiple thereof. Guide pins and guide bushings prevent misconnections and provide easy alignment for accurate mating.

ODU MAC in Alu Frame



This frame has two end pieces and two rails with guiding and mounting hardware. The socket part (receptacle) is generally fixed while the pin part (plug) is typically mounted floating. This frame can accept between 3 to 60 units with a width of 2.54 mm each. For example, if 10 position modules are used, a connector with max. 600 AWG 22 contacts can be assembled.

ODU MAC in DIN Housing with Locking Latch



ODU MAC in DIN housing with locking latch is available in four sizes. Size I accepts 10 modules (2.54 mm ea.) while Size IV accommodates up to 34 models (2.54 mm ea.). Size IV can have max. 340 contacts AWG 22.

ODU MAC in DIN Housing with Locking Spindle



To make the standard DIN housing with locking latch more user-friendly, a quick connect-disconnect locking spindle was developed. As an option, the DIN housings are offered with a precision locking spindle. The locking spindle provides very smooth locking and unlocking of the connector with a single twist.

The locking spindle system is especially designed for high number of connects and disconnects. The precision of the spindle allows more than 5,000 mating cycles.

The Concept of Springtac™ Spring-wire Contacts.

The springwire contact is the invention of Otto Dunkel. The Figure shows a Springtac™ socket and solid pin.

The socket has a multitude of preformed springwires. The springwires are parallel to the plugging direction. They form a flexible cage, with one end fixed at the bottom of the socket, the other end free to move. The springwires are independent from each other and make contact with the surface of the pin.

This arrangement creates in the mated condition an almost constant normal pressure over the entire contact surface of the pin. A springwire socket for a 1.02 mm dia. (AWG 20) pin has about 19 springwires. The number of springwires increases with the size of the contact. This results in many contact points between pin and socket, creating a large contact area for excellent current transmission. Springtac™ contacts are available from 0.6 mm dia. to more than 50 mm dia. They can be supplied with solder, crimp, or threaded stud termination.

Contact retention in a connector insulation body is via military-style contact clips.

The outstanding advantages of ODU Springtac™ contacts are:

- Very high contact reliability
- Low contact resistance
- High current carrying capability
- High resistance to vibration
- Low mating and demating force
- High number of mating cycles
- Long service life

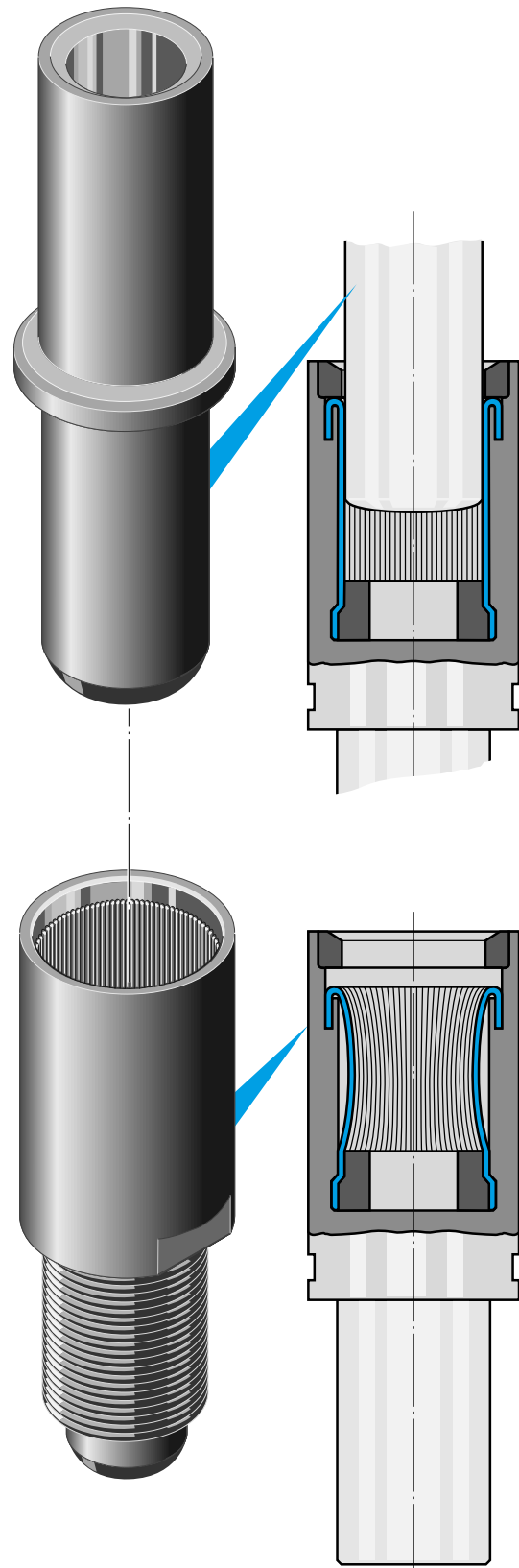
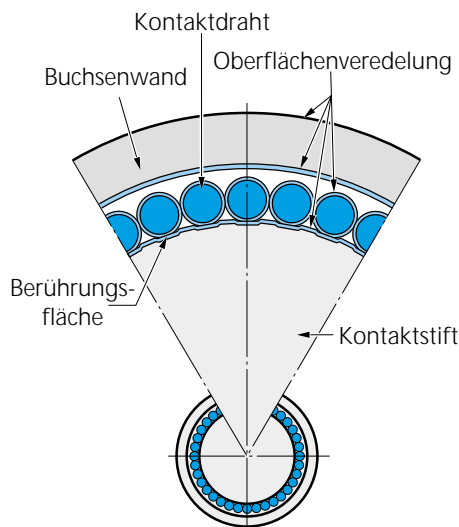

The Modules

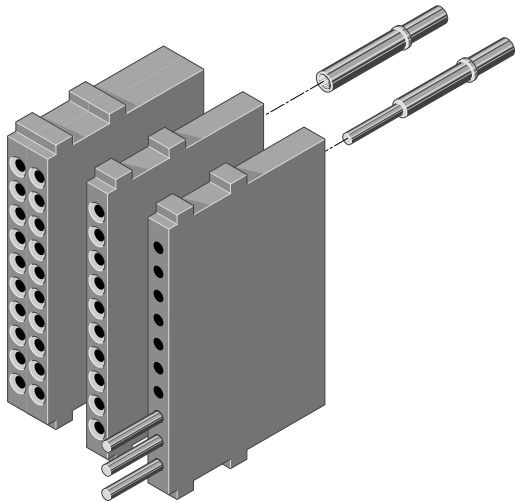

The insulation bodies (modules) are presently available in 23 different versions (sizes as well as number of contacts per module). Figure beside shows a few examples. Insulation bodies are made of glass-filled thermoplastic polyester, UL-94 0 rated. Unit width of a module is 2.54 mm. Modules come in multiples of unit width.

The crimped contacts snap into the cavities from the rear and can be removed in seconds with standard contact removal tools. The modules are locked into the connector frame with locking ridges in grooves.

Contact Retention the Clip Principle

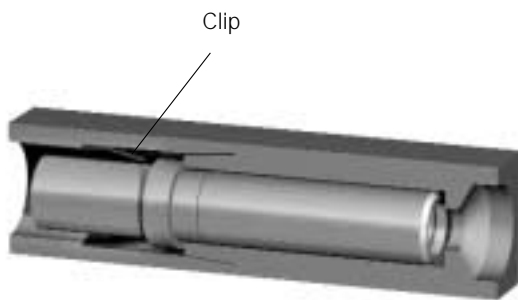
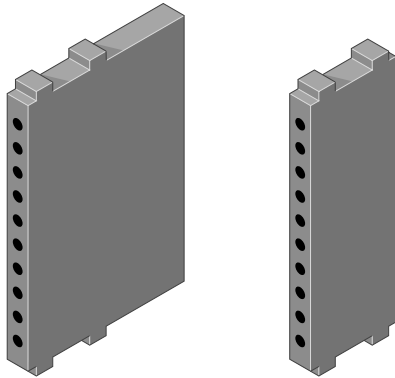

Figure beside shows a contact inside a module. Contacts are inserted from the rear. Retention clips snap over the shoulder of the contact and hold the contact in place. Removal of the contacts is very simple with the use of standard contact removal tools. Although this type of retention clips and insulation bodies require expensive precision production methods, the military-style contact retention system is a very desirable approach to contact retention. It offers significant advantages over fixed contacts. Higher operating voltages for each module can be achieved by leaving adjacent contact cavities empty.

For your notes

Module, 10 Positions
for turned contacts

Spacer (Blank)
(Dummy Module)



Current Information acc. VDE 1)

Reference Voltage:	50 V	20 V
Rated Surge Voltage:	1500 V	1500 V
Degree of Pollution:	2	3

Current Information acc. MIL 2)

Reference Voltage:	500 V
Test Voltage:	1500 V

Total Mating Force (Average):	7,7 N (27 oz.)/Module
Total Demating Force (Average):	7,1 N (25 oz.)/Module
Contact Diameter:	0,76 mm (.030")
Contact Finish:	0,75 µm Au over 1,25 µm Ni (30 µm Au over 50 µm Ni)

Materials:

Insulation Body:	Glass-filled thermoplastic (Polyester), UL-94 V0 rated
Contact Body:	CU-Aloy
Contact Spring:	CuBe
Operating Temperature:	-40 °C up to +125°C

Module, 10 Positions

Spacer (Blank)

Dummy Contact

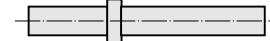
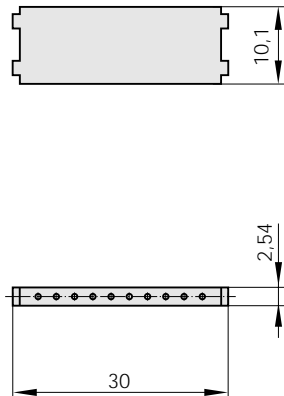
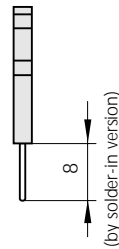
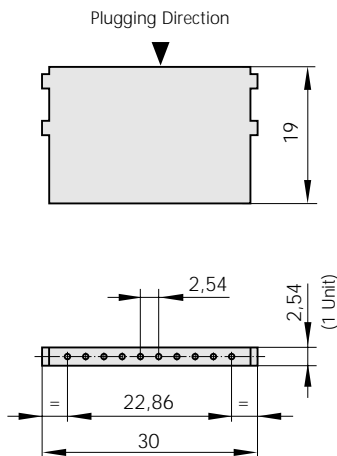

Removal Tool I

Current load only for single contacts. For multiple contacts derate acc. to VDE 0298.



Removal Tool II

	Part Number.	Termination AWG/mm2	max. Cur- rent (A)	Contact Resistance (mΩ) average
Insulation Body	611 122 110 923 000			
Spacer	611 122 111 923 000			
Removal Tool I	087 170 361 000 000			
Removal Tool II	087 611 001 001 000			
Pin Contact*	180 361 000 307 000	AWG 22	5,0	3,8
Grd. Pin Contact*	180 381 000 307 000	AWG 22	5,0	3,8
Socket Contact*	170 361 700 207 000	AWG 22	5,0	3,8
Pin Contact	180 540 000 307 000	AWG 24/28	1,5	3,8
Grd. Pin Contact	180 570 000 307 000	AWG 24/28	1,5	3,8
Socket Contact	170 540 700 207 000	AWG 24/28	1,5	3,8
Pin Contact	180 850 000 307 000	PCB	5,0	3,8
Grd. Pin Contact	180 851 000 307 000	Solder Pin	5,0	3,8
Socket Contact	170 850 700 207 000	Ø 0,76	5,0	3,8
Dummy Contact	021 341 123 300 000			

* Non magnetic on request

Crimp Instructions see page 46/47

1) see page 56

2) see page 59

Module, 10 Positions
for stamped contacts

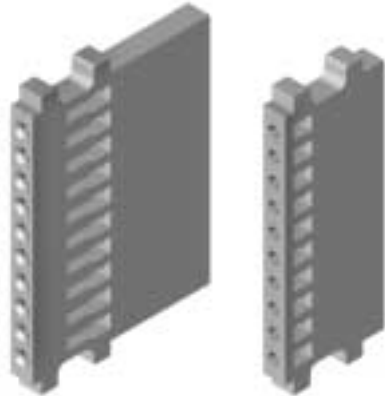

Socket

Stift

Current Information acc. VDE ¹⁾

Reference Voltage:	32 V	10 V
Rated Surge Voltage:	1500 V	1500 V
Degree of Pollution:	2	3

Current Information acc. MIL ²⁾

Reference Voltage:	450 V
Test Voltage:	1350 V

Total Mating Force (Average):	7,4 N (26 oz./)Module
Total Demating Force (Average):	6,5 N (23 oz./)Module
Contact Diameter:	0,7 mm (.028")
Contact Finish on termination area:	3 µm Sn (120 µ" Sn)
Contact Finish on contact area:	0,75 µm Au (30 µ" Au)

Materials:

Insulation Body:	Glass-filled thermoplastic (Polyester), UL-94 V0 rated
Contact:	CuSn 6
Operating Temperature:	-40 °C up to +125°C

Module, 10 Positions
Socket (Crimp termination)

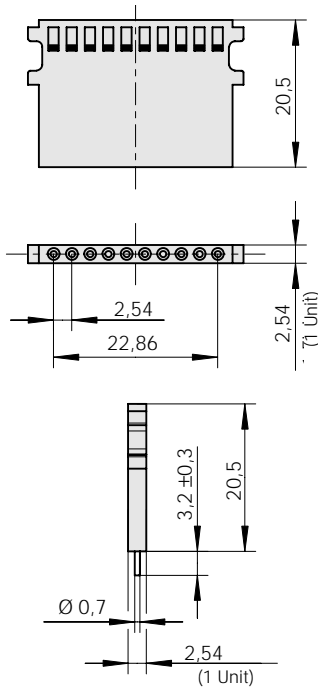

Module, 10 Positions
Pin (Crimp termination)

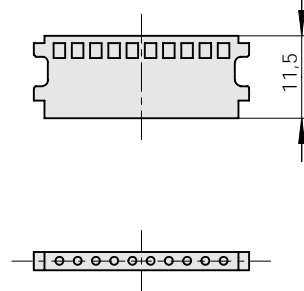

Spacer

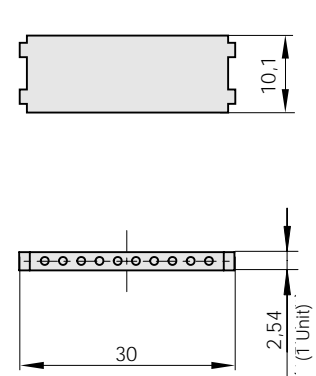

Socket 0,7

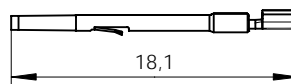

Pin S 0,7

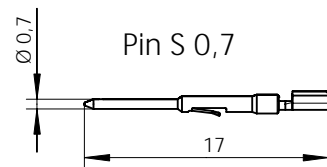

	Part Number.	Termination AWG/mm2	max. Cur- rent (A)	Contact Resistance (mΩ) average
Insulation Body Socket (Crimp)	610 158 110 923 000			
Insulation Body Pin (Crimp)	611 158 110 923 000			
Insulation Body Socket (Print)	610 158 010 923 000			
Spacer	611 122 111 923 000			
Pin Contact	186 080 103 535 1..*	26/28	3,5	3,8
Socket Contact	176 082 103 535 1..*	26/28	3,5	3,8
Pin Contact	186 080 103 535 2..*	22/24	4,5	3,8
Socket Contact	176 082 103 535 2..*	22/24	4,5	3,8

Contacts not removable

¹⁾ see page 56

²⁾ see page 59

* Packaging units for Crimpversion

- .51 = 500 pcs on tape
- .52 = 900 pcs on tape
- .54 = 5 000 pcs on tape
- .55 = 10 000 pcs on tape
- .50 = 20 000 pcs on tape

Crimp Instructions see page 46/47

The 10 position modules with turned and stamped contacts are not mating compatible.

Module, for Print, Wire Wrap Termination and IDC-connectors

10 Positions

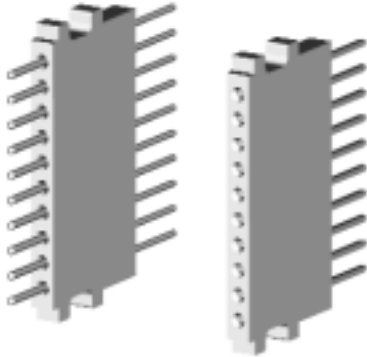

6 Positions

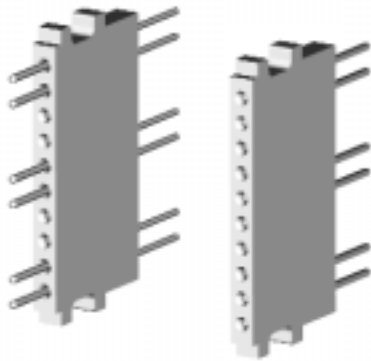

Current Information acc. VDE 1)

Reference Voltage:	50 V	20 V
Rated Surge Voltage:	1500 V	1500 V
Degree of Pollution:	2	3

Current Information acc. MIL 2)

Reference Voltage:	500 V
Test Voltage:	1500 V

Total Mating Force (Average):	7,7 N (27 oz.)/Module
Total Demating Force (Average):	7,1 N (25 oz.)/Module
Contact Diameter:	0,76 mm (.030")
Contact Finish:	0,75 µm Au over 1,25 µm Ni (30 µ" Au over 50 µ" Ni)

Materials:

Insulation Body:	Glass-filled thermoplastic (Polyester), UL-94 V0 rated
Contact Body:	CU-Alloy
Contact Spring:	CuBe
Operating Temperature:	-20 °C up to +105 °C

Pin Insert

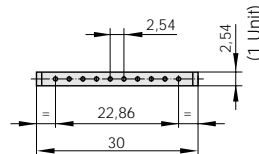
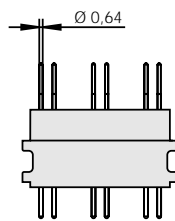
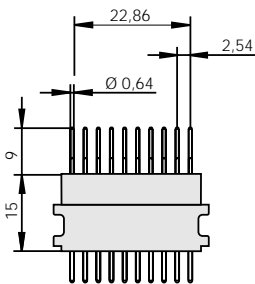

Socket Insert

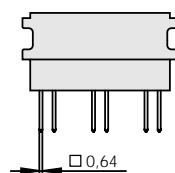
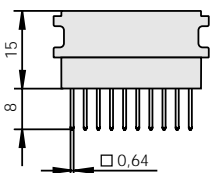

	10 Positions	6 Positions	Print	Termination for IDC-connectors	Wire Wrap
Pin Insert	611 146 010 923 000	611 146 006 923 000	•	•	-
Socket Insert	610 146 010 923 000	610 146 006 923 000	•	•	•

1) see page 56

2) see page 59

Module 6 Positions

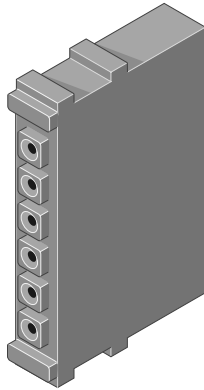

Spacer (Blank)
(Dummy Module)

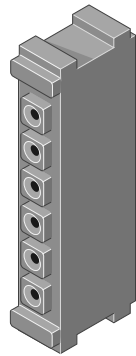

Current Information acc. VDE ¹⁾

Reference Voltage:	200 V	63 V
Rated Surge Voltage:	2500 V	2500 V
Degree of Pollution:	2	3

Current Information acc. MIL ²⁾

Reference Voltage:	850 V
Test Voltage:	2550 V

Total Mating Force (Average):	6,5 N (23 oz.)/Module
Total Demating Force (Average):	6,0 N (22 oz.)/Module
Contact Diameter:	1,02 mm (.040")
Contact Finish:	0,75 µm Au over 1,25 µm Ni (30 µm Au over 50 µm Ni)

Materials:

Insulation Body:	Glass-filled thermoplastic (Polyester), UL-94 V0 rated
Contact Body:	CU-Aloy
Contact Spring:	CuBe

Operating Temperature:	-40°C up to +125°C
------------------------	--------------------

Module, 6 Positions

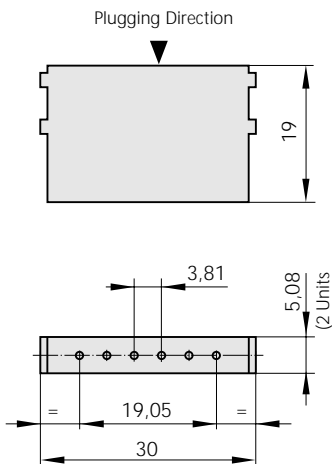

Spacer (Blank)

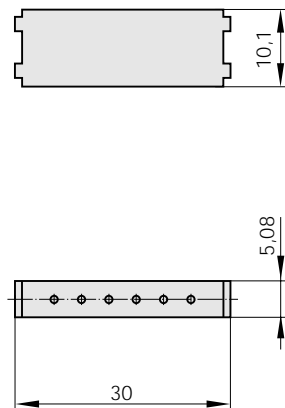
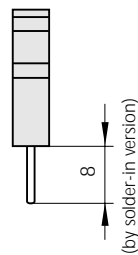

Dummy Contact



Removal Tool I



Removal Tool II

Current load only for single contacts. For multiple contacts derate acc. to VDE 0298.

	Part Number.	Termination AWG/mm ²	max. Current (A)	Contact Resistance (mΩ) average
Insulation Body	611 123 106 923 000			
Spacer	611 123 111 923 000			
Removal Tool I	087 170 362 000 000			
Removal Tool II	087 611 001 001 000			
Pin Contact*	180 362 000 307 000	AWG 20/22	6,0	2,1
Grd. Pin Contact*	180 382 000 307 000	AWG 20/22	6,0	2,1
Socket Contact*	170 362 700 207 000	AWG 20/22	6,0	2,1
Pin Contact	180 544 000 307 000	AWG 24/28	2,0	2,1
Grd. Pin Contact	180 574 000 307 000	AWG 24/28	2,0	2,1
Socket Contact	170 544 700 207 000	AWG 24/28	2,0	2,1
Pin Contact	180 818 000 307 000	PCB	6,0	2,1
Grd. Pin Contact	180 819 000 307 000	Solder Pin	6,0	2,1
Socket Contact	170 818 700 207 000	Ø 1,0	6,0	2,1
Dummy Contact	021 341 124 300 000			

* Non magnetic on request

¹⁾ see page 56

²⁾ see page 59

Crimp Instructions see page 46/47

Module 14 Positions

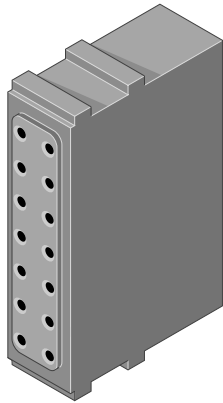

Spacer (Blank)
(Dummy module)

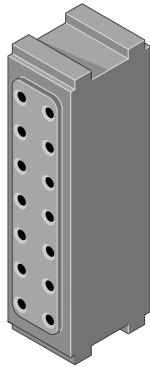

Current Information acc. VDE 1)

Reference Voltage:	160 V	32 V
Rated Surge Voltage:	2500 V	2500 V
Degree of Pollution:	2	3

Current Information acc. MIL 2)

Reference Voltage:	950 V
Test Voltage:	2850 V

Total Mating Force (Average):	14,2 N (51 oz./Module)
Total Demating Force (Average):	13,5 N (49 oz./Module)
Contact Diameter:	1,02 mm (.040")
Contact Finish:	0,75 µm Au over 1,25 µm Ni (30 µm Au over 50 µm Ni)

Materials:

Insulation Body:	Glass-filled thermoplastic (Polyester), UL-94 V0 rated
Contact Body:	CU-Aloy
Contact Spring:	CuBe
Operating Temperature:	-40°C up to +125°C

Module, 14 Positions

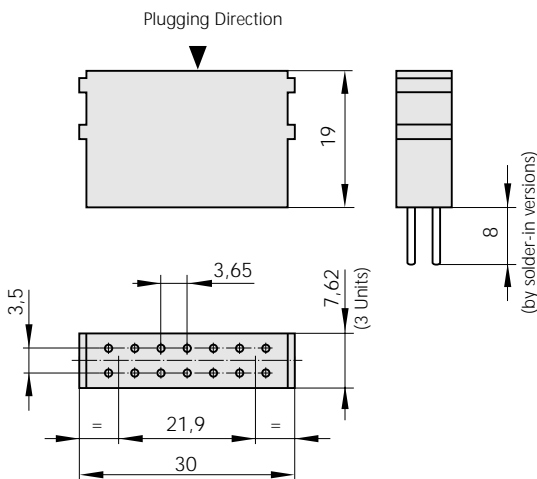

Spacer (Blank)

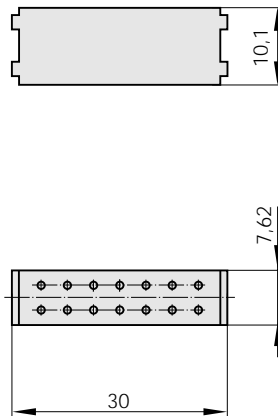

Dummy Contact



Removal Tool I



Removal Tool II

Current load only for single contacts.
For multiple contacts derate acc. to VDE 0298.

	Part Number.	Termination AWG/mm2	max. Cur- rent (A)	Contact Resistance (mΩ) average
Insulation Body	611 130 114 923 000			
Spacer	611 130 111 923 000			
Removal Tool I	087 170 362 000 000			
Removal Tool II	087 611 001 001 000			
Pin Contact*	180 362 000 307 000	AWG 20/22	6,0	2,1
Grd. Pin Contact*	180 382 000 307 000	AWG 20/22	6,0	2,1
Socket Contact*	170 362 700 207 000	AWG 20/22	6,0	2,1
Pin Contact	180 544 000 307 000	AWG 24/28	2,0	2,1
Grd. Pin Contact	180 574 000 307 000	AWG 24/28	2,0	2,1
Socket Contact	170 544 700 207 000	AWG 24/28	2,0	2,1
Pin Contact	180 818 000 307 000	PCB	6,0	2,1
Grd. Pin Contact	180 819 000 307 000	Solder Pin	6,0	2,1
Socket Contact	170 818 700 207 000	∅ 1,02	6,0	2,1
Dummy Contact	021 341 124 300 000			

* Non magnetic on request

1) see page 56

2) see page 59

Crimp Instructions see page 46/47

Module 5 Positions

Spacer (Blank)
(Dummy module)

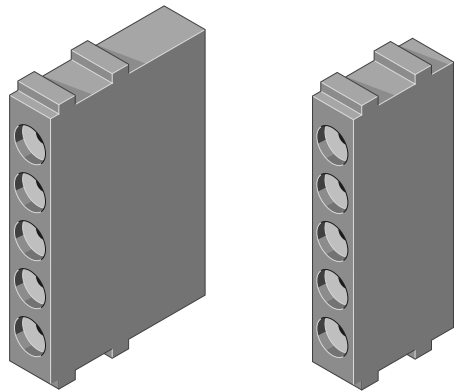

Current Information acc. VDE 1)

Reference Voltage:	250 V	40 V
Rated Surge Voltage:	2500 V	2500 V
Degree of Pollution:	2	3

Current Information acc. MIL 2)

Reference Voltage:	750 V
Test Voltage:	2250 V

Total Mating Force (Average):	10,2 N (37 oz.)/Module
Total Demating Force (Average):	8,5 N (31 oz.)/Module
Contact Diameter:	1,5 mm (.059")

Contact Finish:

Contact Body: 0,75 µm Au over 1,25 µm Ni
(30 µ" Au over 50 µ" Ni)

Contact Springs: 6 µm Ag (240 µ" Ag)

Materials:

Insulation Body: Glass-filled thermoplastic (Polyester), UL-94 V0 rated

Contact Body: CU-Aloy

Contact Spring: CuSn

Operating Temperature: -40°C up to +125°C

Module, 5 Positions

Plugging Direction

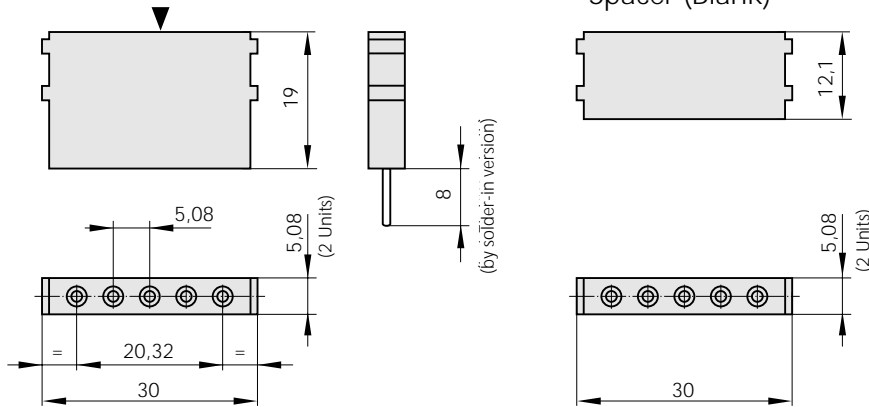

Current load only for single contacts.
For multiple contacts derate acc. to VDE 0298.

	Part Number.	Termination AWG/mm ²	max. Cur- rent (A)	Contact Resistance (mΩ) average
Insulation Body 5polig	611 124 105 923 000			
Spacer	611 124 111 923 000			
Removal Tool I	087 170 137 000 000			
Removal Tool II	087 611 001 001 000			
Pin Contact*	180 363 000 307 000	1,5 mm ²	18,0	0,95
Grd. Pin Contact*	180 383 000 307 000	1,5 mm ²	18,0	0,95
Socket Contact*	170 363 700 201 000	1,5 mm ²	18,0	0,95
Pin Contact	180 543 000 307 000	AWG 16	15,0	0,95
Grd. Pin Contact	180 573 000 307 000	AWG 16	15,0	0,95
Socket Contact	170 543 700 201 000	AWG 16	15,0	0,95
Pin Contact	180 545 000 307 000	1 mm ²	13,0	0,95
Grd. Pin Contact	180 575 000 307 000	1 mm ²	13,0	0,95
Socket Contact	170 545 700 201 000	1 mm ²	13,0	0,95
Pin Contact	180 541 000 307 000	AWG 20/22	7,5	0,95
Grd. Pin Contact	180 571 000 307 000	AWG 20	7,5	0,95
Socket Contact	170 541 700 201 000	AWG 20/22	7,5	0,95
Pin Contact	180 857 000 307 000	AWG 24/28	2,0	0,95
Grd. Pin Contact	180 856 000 307 000	AWG 24/28	2,0	0,95
Socket Contact	170 857 700 201 000	AWG 24/28	2,0	0,95
Pin Contact	180 539 000 307 000	PCB	18,0	0,95
Grd. Pin Contact	180 569 000 307 000	Solder Pin	18,0	0,95
Socket Contact	170 539 700 201 000	Ø 1,5	18,0	0,95
Dummy Contact	021 341 125 300 000			

* Non magnetic on request

Dummy Contact



Removal Tool I



Removal Tool II



1) see page 56

2) see page 59

Crimp Instructions see page 46/47

Module 4 Positions Spacer (Blank) (Dummy module)

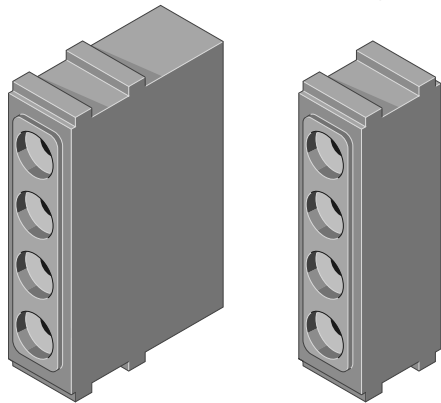

Current Information acc. VDE 1)

Reference Voltage:	320 V	160 V
Rated Surge Voltage:	2500 V	2500 V
Degree of Pollution:	2	3

Current Information acc. MIL 2)

Reference Voltage:	1100 V
Test Voltage:	3300 V

Total Mating Force (Average): 19,5 N (70 oz.)/Module

Total Demating Force (Average): 17,0 N (61 oz.)/Module

Contact Diameter: 2,41 mm (.095")

Contact Finish: 6 µm Ag (240 µ" Ag)

Materials:

Insulation Body: Glass-filled thermoplastic (Polyester), UL-94 V0 rated

Contact Body: CU-Aloy

Contact Spring: CuSn

Operating Temperature: -40°C up to +125°C

Module, 4 Positions

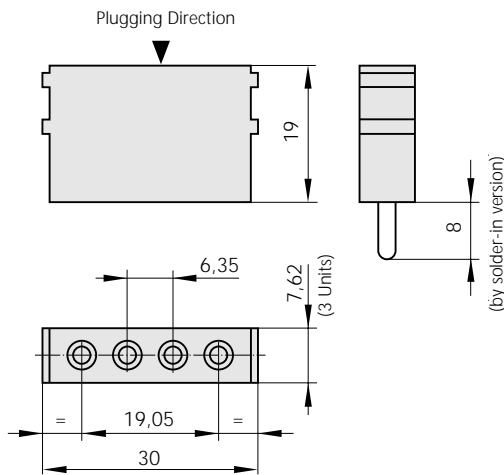

Spacer (Blank)

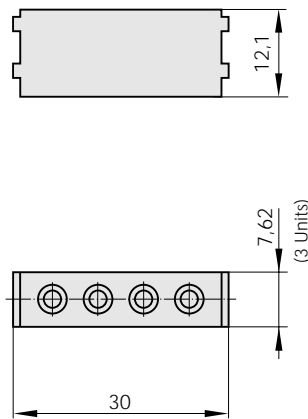

Dummy Contact

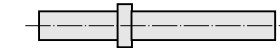

Removal Tool I



Removal Tool II

Current load only for single contacts.
For multiple contacts derate acc. to VDE 0298.

other contact Ø on request

	Part Number.	Termination AWG/mm ²	max. Cur- rent (A)	Contact Resistance (mΩ) average
Insulation Body 4polig	611 126 104 923 000			
Spacer	611 126 111 923 000			
Removal Tool I	087 170 365 000 000			
Removal Tool II	087 611 001 001 000			
Pin Contact	180 365 000 301 000	AWG 12	23,0	0,41
Grd. Pin Contact	180 385 000 301 000	AWG 12	23,0	0,41
Socket Contact	170 365 100 201 000	AWG 12	23,0	0,41
Pin Contact*	180 910 000 301 000	2,5 mm ²	23,0	1,00
Grd. Pin Contact*	180 911 000 301 000	2,5 mm ²	23,0	1,00
Socket Contact*	170 910 100 201 000	2,5 mm ²	23,0	1,00
Pin Contact	182 607 000 301 000	1,5 mm ²	18,0	1,00
Grd. Pin Contact	182 604 000 301 000	1,5 mm ²	18,0	1,00
Socket Contact	172 604 100 201 000	1,5 mm ²	18,0	1,00
Pin Contact	182 606 000 301 000	1,0 mm ²	13,0	1,00
Grd. Pin Contact	182 603 000 301 000	1,0 mm ²	13,0	1,00
Socket Contact	172 603 100 201 000	1,0 mm ²	13,0	1,00
Pin Contact	182 608 000 301 000	AWG 20/22	7,5	1,00
Grd. Pin Contact	182 605 000 301 000	AWG 20/22	7,5	1,00
Socket Contact	172 605 100 201 000	AWG 20/22	7,5	1,00
Pin Contact	180 820 000 301 000	PCB	23,0	0,41
Grd. Pin Contact	180 821 000 301 000	Solder Pin	23,0	0,41
Socket Contact	170 820 100 201 000	Ø 2,4	23,0	0,41
Dummy Contact	021 341 127 300 000			

* Non magnetic on request

1) see page 56

2) see page 59

Crimp Instructions see page 46/47

Module 3 Positions

Spacer (Blank)
(Dummy module)

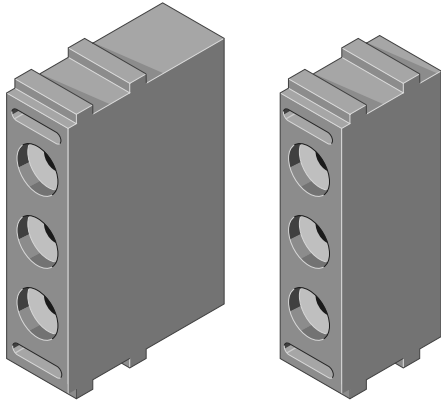

Current Information acc. VDE 1)

Reference Voltage:	250 V	100 V
Rated Surge Voltage:	2500 V	2500 V
Degree of Pollution:	2	3

Current Information acc. MIL 2)

Reference Voltage:	1200 V
Test Voltage:	3600 V

Total Mating Force (Average):	18,5 N (67 oz.)/Module
Total Demating Force (Average):	16,0 N (58 oz.)/Module
Contact Diameter:	3,0 mm (.118")
Contact Finish:	6 µm Ag (240 µ" Ag)

Materials:

Insulation Body:	Glass-filled thermoplastic (Polyester), UL-94 V0 rated
Contact Body:	CU-Aloy
Contact Spring:	CuSn
Operating Temperature:	-40°C up to +125°C

Module, 3 Positions

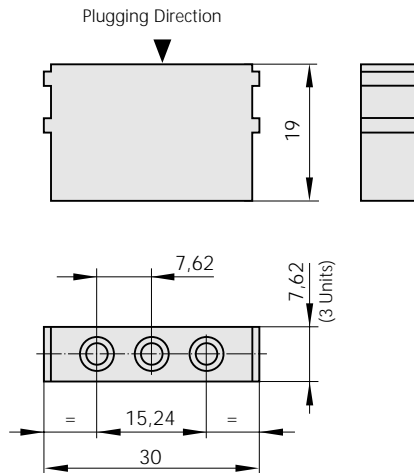

Spacer (Blank)

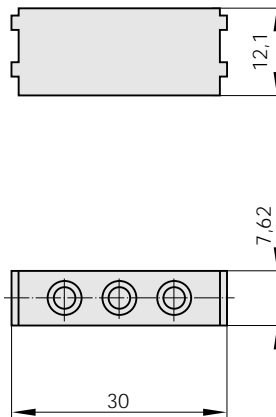

Dummy Contact

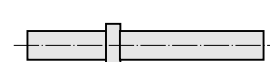

Current load only for single contacts.
For multiple contacts derate acc. to VDE 0298.

other contact Ø on request

	Part Number.	Termination mm ²	max. Current (A)	Contact Resistance (mΩ) average
Insulation Body 3polig	611 127 103 923 000			
Spacer	611 127 111 923 000			
Removal Tool I	087 170 136 000 000			
Removal Tool II	087 611 001 001 000			
Pin Contact	180 366 000 301 000	4,0 mm ²	30	0,30
Grd. Pin Contact	180 386 000 301 000	4,0 mm ²	30	0,30
Socket Contact	172 366 100 201 000	4,0 mm ²	30	0,30
Pin Contact	180 546 000 301 000	2,5 mm ²	26	0,30
Grd. Pin Contact	180 576 000 301 000	2,5 mm ²	26	0,30
Socket Contact	170 546 100 201 000	2,5 mm ²	26	0,30
Pin Contact	182 582 000 301 000	1,5 mm ²	18	1,00
Grd. Pin Contact	182 583 000 301 000	1,5 mm ²	18	1,00
Socket Contact	172 582 100 201 000	1,5 mm ²	18	1,00
Pin Contact	182 584 000 301 000	1,0 mm ²	13	1,00
Grd. Pin Contact	182 585 000 301 000	1,0 mm ²	13	1,00
Socket Contact	172 584 100 201 000	1,0 mm ²	13	1,00
Pin Contact	182 586 000 301 000	AWG 20/22	7.5	1,00
Grd. Pin Contact	182 587 000 301 000	AWG 20/22	7.5	1,00
Socket Contact	172 586 100 201 000	AWG 20/22	7.5	1,00
Dummy Contact	021 341 128 300 000			

1) see page 56

2) see page 59

Crimp Instructions see page 46/47

Module 3 Positions Spacer (Blank)
(Dummy Module)

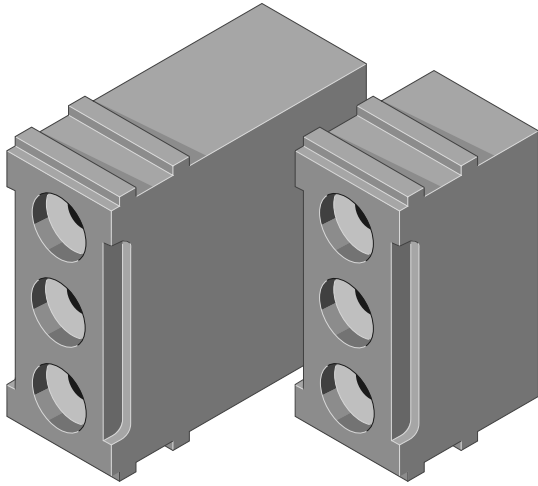

Current Information acc. VDE 1)

Reference Voltage:	250 V	160 V
Rated Surge Voltage:	2500 V	2500 V
Degree of Pollution:	2	3

Current Information acc. MIL 2)

Reference Voltage:	1250 V
Test Voltage:	3750 V

Total Mating Force (Average):	18,5 N (67 oz.)/Module
Total Demating Force (Average):	16,0 N (58 oz.)/Module
Contact Diameter:	4,0 mm (.157")
Contact Finish:	6 µm Ag (240 µ" Ag)

Materials:

Insulation Body:	Glass-filled thermoplastic (Polyester), UL-94 V0 rated
Contact Body:	Cu-Alloy
Contact Spring:	CuSn
Operating Temperature:	-40°C up to +125°C

Module, 3 Positions

Plugging Direction

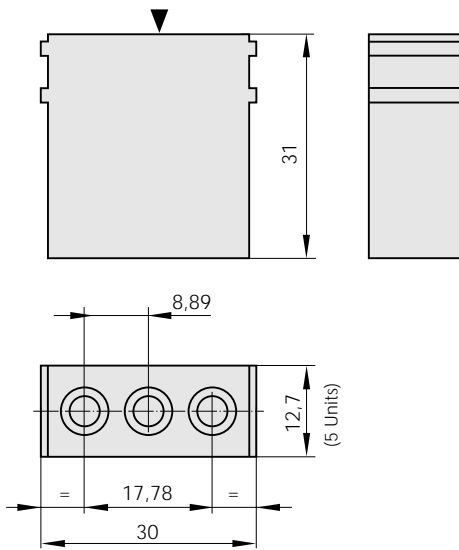

Spacer (Blank)

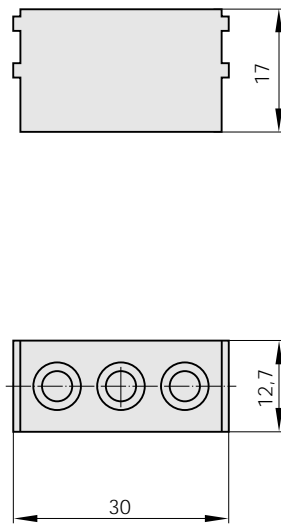

Dummy Contact



Removal Tool I



Removal Tool II

Current load only for single contacts.
For multiple contacts derate acc. to VDE 0298.

	Part Number.	Termination mm ²	max. Current (A)	Contact Resistance (mΩ) average
Insulation Body 3polig	611 128 103 923 000			
Spacer	611 128 111 923 000			
Removal Tool I	087 170 367 000 000			
Removal Tool II	087 611 001 001 000			
Pin Contact	180 367 000 301 000	6,0 mm ²	40	0,28
Grd. Pin Contact	180 387 000 301 000	6,0 mm ²	40	0,28
Socket Contact	170 367 100 201 000	6,0 mm ²	40	0,28
Dummy Contact	021 341 129 923 000			

1) see page 56

2) see page 59

Crimp Instructions see page 46/47

Module 2 Positions Spacer (Blank) (Dummy Module)

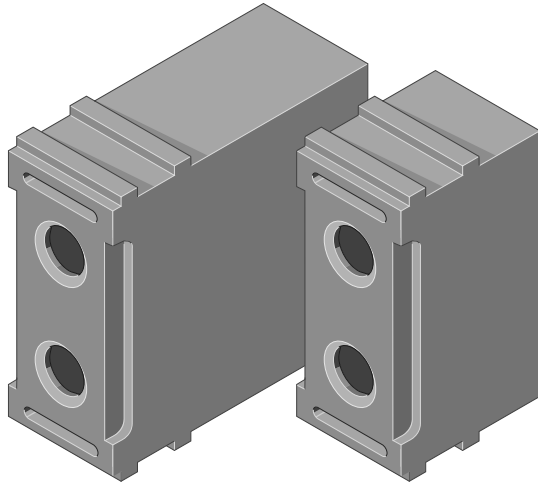

Current Information acc. VDE 1)

Reference Voltage:	250 V	160 V
Rated Surge Voltage:	2500 V	2500 V
Degree of Pollution:	2	3

Current Information acc. MIL 2)

Reference Voltage:	1250 V
Test Voltage:	3750 V

Total Mating Force (Average):	22,0 N (79 oz.)/Module
Total Demating Force (Average):	18,0 N (65 oz.)/Module
Contact Diameter:	5,0 mm (.197")
Contact Finish:	6 µm Ag (240 µ" Ag)

Materials:

Insulation Body:	Glass-filled thermoplastic (Polyester), UL-94 V0 rated
Contact Body:	CU-Aloy
Contact Spring:	CuSn
Operating Temperature:	-40°C up to +125°C

Module, 2 Positions

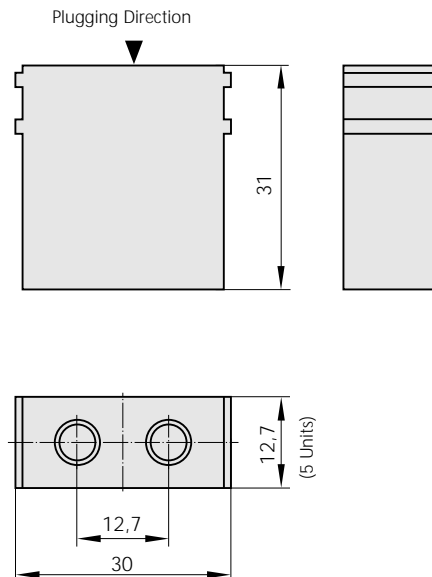

Spacer (Blank)

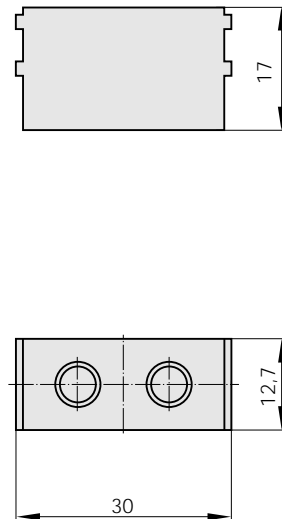

Dummy Contact

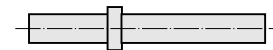

Removal Tool I



Removal Tool II

Current load only for single contacts.
For multiple contacts derate acc. to VDE 0298.

	Part Number.	Termination mm ²	max. Current (A)	Contact Resistance (mΩ) average
Insulation Body 2polig	611 129 102 923 000			
Spacer	611 129 111 923 000			
Removal Tool I	087 170 391 000 000			
Pin Contact	180 490 000 301 000	10,0 mm ²	60	0,21
Grd. Pin Contact	180 491 000 301 000	10,0 mm ²	60	0,21
Socket Contact	170 490 100 201 000	10,0 mm ²	60	0,21
Pin Contact	180 369 000 301 000	4,0 mm ²	34	0,21
Grd. Pin Contact	180 389 000 301 000	4,0 mm ²	34	0,21
Socket Contact	170 369 100 201 000	4,0 mm ²	34	0,21
Dummy Contact	021 341 130 923 000			

1) see page 56

2) see page 59

Crimp Instructions see page 46/47

Module 4 Positions for high voltage contacts

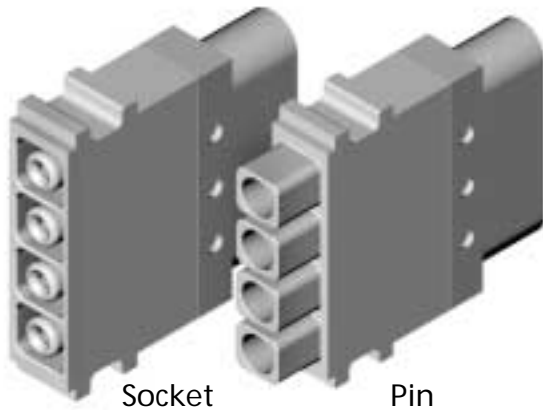

Current Information acc. VDE ¹⁾

Reference Voltage:	2500 V	1000 V
Rated Surge Voltage:	10000 V	8000 V
Degree of Pollution:	2	3

Current Information acc. MIL ²⁾

Reference Voltage:	2500 V
Test Voltage:	7500 V

Total Mating Force (Average):	10,2 N (36 oz.)/Module
Total Demating Force (Average):	8,5 N (30 oz.)/Module
Contact Diameter:	1,5 mm (.039")
Contact Finish:	0,75 µm Au over 1,25 µm Ni (30 µm Au over 50 µm Ni)

Materials:

Insulation Body:	Glass-filled thermoplastic (Polyester), UL-94 V0 rated
Contact Body:	CU-Aloy
Contact Spring:	CuSn
Operating Temperature:	-40°C up to +125°C

Module Socket, 4 Positions

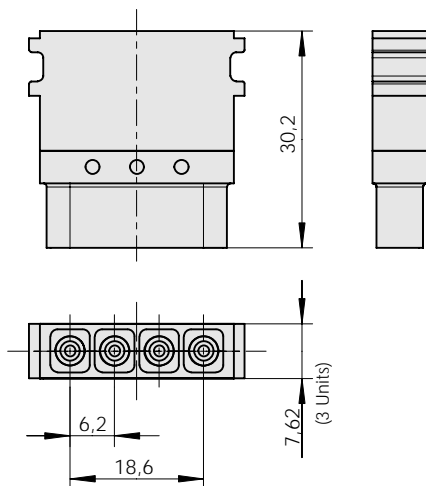

Module Pin, 4 Positions

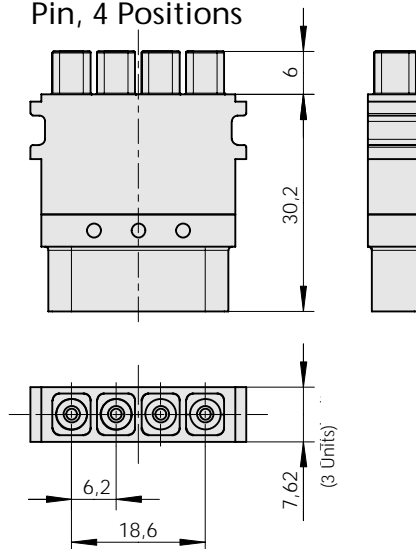

Spacer (Blank)

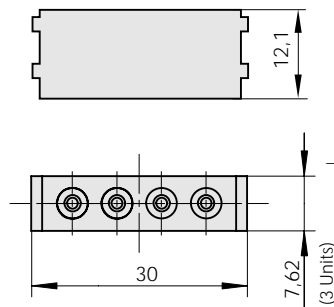

Dummy Contact



Removal Tool I



Removal Tool II

¹⁾ see page 56

²⁾ see page 59

Crimp Instructions see page 46/47

	Part Number.	Termination AWG/mm ²	max. Cur- rent (A)	Contact Resistance (mΩ) average
Insulation Body (Socket)	610 159 104 923 000			
Insulation Body (Pin)	611 159 104 923 000			
Spacer	611 126 111 923 000			
Removal Tool I	087 170 137 000 000			
Removal Tool II	087 611 001 001 000			
Pin Contact*	180 363 000 307 000	1,5 mm ²	18,0	0,95
Grd. Pin Contact*	180 383 000 307 000	1,5 mm ²	18,0	0,95
Socket Contact*	170 363 700 201 000	1,5 mm ²	18,0	0,95
Pin Contact	180 543 000 307 000	AWG 16	15,0	0,95
Grd. Pin Contact	180 573 000 307 000	AWG 16	15,0	0,95
Socket Contact	170 543 700 201 000	AWG 16	15,0	0,95
Pin Contact	180 545 000 307 000	1 mm ²	13,0	0,95
Grd. Pin Contact	180 575 000 307 000	1 mm ²	13,0	0,95
Socket Contact	170 545 700 201 000	1 mm ²	13,0	0,95
Pin Contact	180 541 000 307 000	AWG 20/22	7,5	0,95
Grd. Pin Contact	180 571 000 307 000	AWG 20	7,5	0,95
Socket Contact	170 541 700 201 000	AWG 20/22	7,5	0,95
Pin Contact	180 857 000 307 000	AWG 24/28	2,0	0,95
Grd. Pin Contact	180 856 000 307 000	AWG 24/28	2,0	0,95
Socket Contact	170 857 700 201 000	AWG 24/28	2,0	0,95
Pin Contact	180 539 000 307 000	PCB	18,0	0,95
Grd. Pin Contact	180 569 000 307 000	Solder-Pin	18,0	0,95
Socket Contact	170 539 700 201 000	Ø 1,5	18,0	0,95
Dummy Contact	021 341 125 300 000			

* Non magnetic on request

**Module 4 Positions
for 50 Ω Coax-Contacts
non magnetic with the clip principle**

Frequency range: 0-1,2 GHz
Current Information acc. MIL 2)
 Reference Voltage: 350 V
 Test Voltage: 1050 V

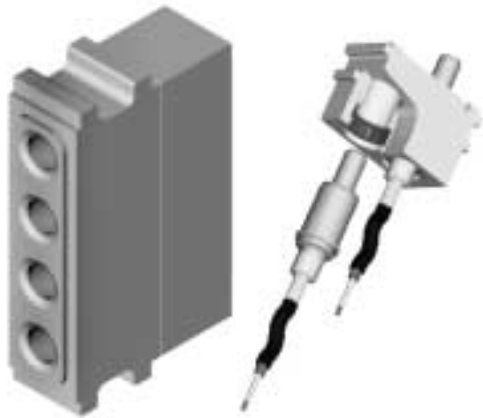

Insulation resistance: >100 G Ω
 Total Mating Force (Average): 17 N (60 oz.)/Module
 Total Demating Force (Average): 14 N (49 oz.)/Module
Materials:
 Insulation Body: Glass-filled thermoplastic (Polyester), UL-94 V0 rated
 Contact Body: CU-Aloy
 Contact Spring-center contact: CuSn
 Contact Spring-outer contact: CuBe
Contact Finish:
 Pin, center contact: 0,8 μm Au over 2 μm white bronze
 Pin, outer contact: (32 μm Au over 50 μm white bronze)
 Socket, center contact:
 Socket, outer contact:
 Operating Temperature: -40°C up to +125°C

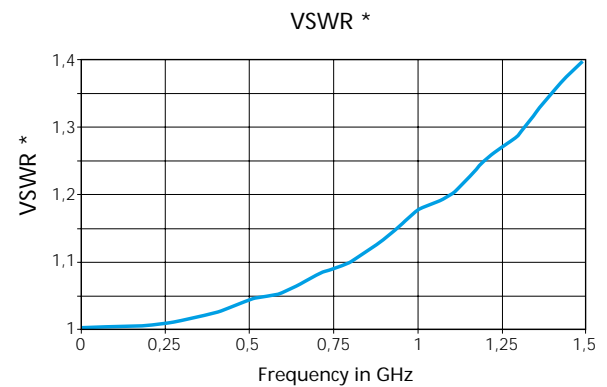
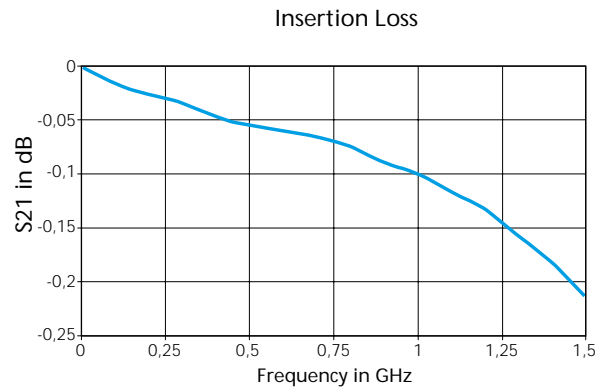
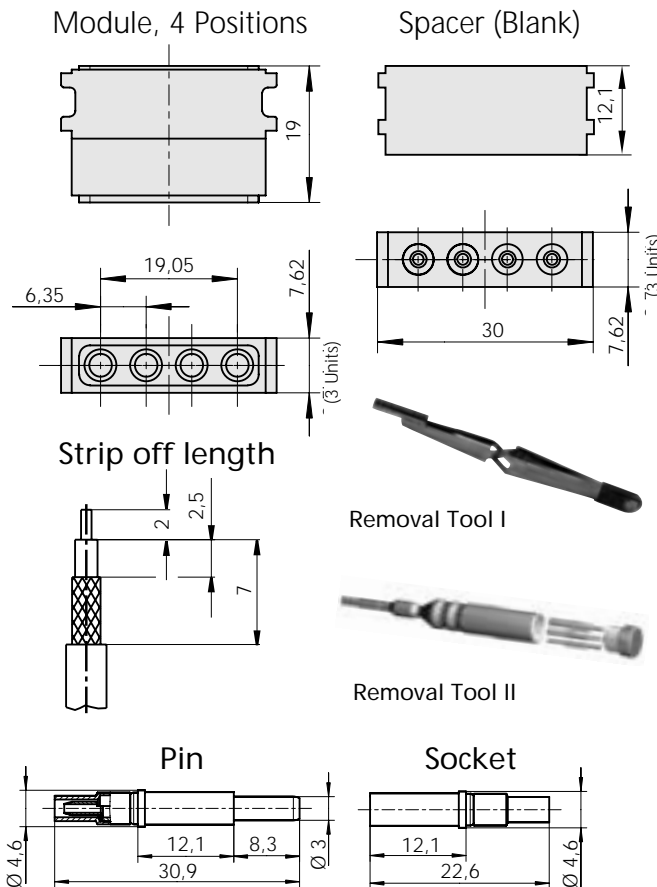

*Voltage standing wave ratio

	Part Number	Cable impedance (Ω)	Cable	Crimp Dies Part Number
Insulation Body	611 149 104 923 000			
Spacer	611 126 111 923 000			
Removal Tool I	087 170 365 000 000			
Removal Tool II	087 611 001 001 000			
Pin Contact straight	122 120 001 257 000	50	RG 178 / RG 196	082 000 039 101 000
Pin Contact straight	122 120 003 257 000	50	RG 174 / RG 188 / RG 316 (75 Ω: RG 179, RG 187)	082 000 039 102 000
Socket Contact straight	122 120 002 257 000	50	RG 178, RG 196	082 000 039 101 000
Socket Contact straight	122 120 004 257 000	50	RG 174 / RG 188 / RG 316 (75 Ω: RG 179, RG 187)	082 000 039 102 000

2) see page 59

Crimp Instructions see page 46/47

Module 2 Positions for 50 Ω Coax-Contacts in the clip principle

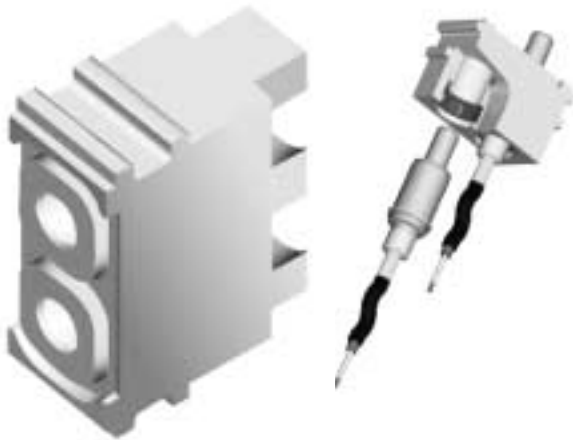

Frequency range: 0-2,5 GHz
Current Information acc. MIL 2)
 Reference Voltage: 400 V
 Test Voltage: 1200 V

Insulation resistance: >100 GΩ
 Total Mating Force (Average): 9 N (32 oz.)/Module
 Total Demating Force (Average): 7,5 N (26 oz.)/Module

Materials:

Insulation Body: Glass-filled thermoplastic (Polyester), UL-94 V0 rated
 Contact Body: Cu-Alloy
 Contact Spring: CuSn

Contact Finish:

Pin, center contact: 0,75 μm Au over 1,25 μm Ni (30 μm Au over 50 μm Ni)
 Pin, outer contact: 6 μm Ni (240 μm Ni)
 Socket, center contact: Springs 0,75 μm Au over 1,25 μm Ni (30 μm Au over 50 μm Ni)
 Socket, outer contact: Springs 0,75 μm Au over 1,25 μm Ni (30 μm Au over 50 μm Ni)
 Operating Temperature: -40°C up to +125°C

Module, Pin and Socket, 2 Positions

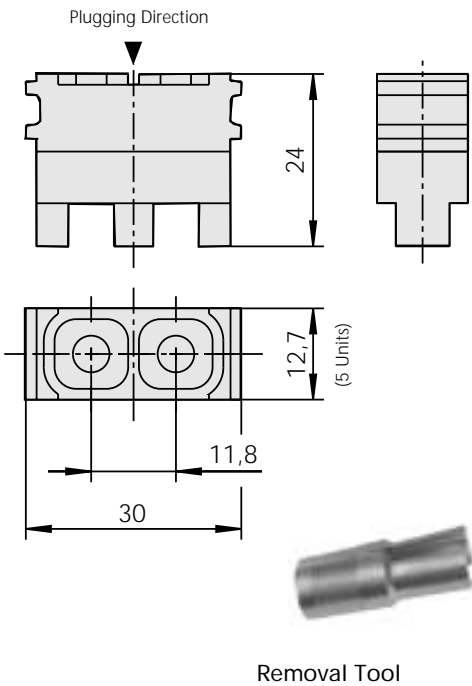

High frequency characteristics of the 50 Ω Coaxial Contacts

Strip off length

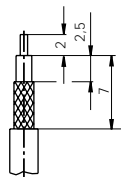

Cable termination

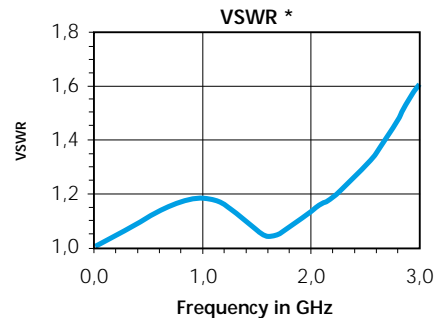
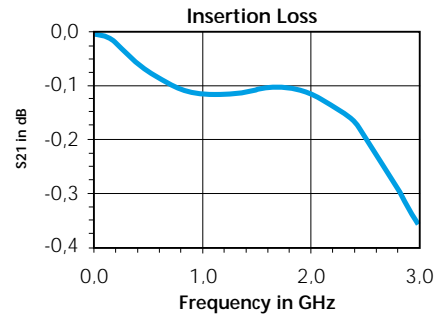
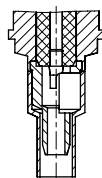

Center contact soldered
 Outer contact soldered or crimped

*Voltage standing wave ratio

	Part Number.	Cable Impedance (Ω)	Cable	Crimp Dies Part Number
Insulation Body	611 152 102 923 000			
Spacer	611 129 111 923 000			
Dummy Contact	021 341 177 300 000			
Removal Tool	087 170 391 000 000			
Pin Contact straight	122 346 001 207 000	50	RG 178 / RG 196	082 000 039 101 000
Pin Contact straight	122 346 003 207 000	50	RG 174 / RG 188 / RG 316	082 000 039 102 000
Pin Contact straight	122 346 005 207 000	50	RG 122 (2ZCY 0.4/2.5-75 Ω)	082 000 039 104 000
Pin Contact straight	122 346 007 207 000	50	RG 58	082 000 039 106 000
Pin Contact straight	122 346 009 207 000	50	RG 223	082 000 039 106 000
Socket Contact straight	122 346 002 207 000	50	RG 178 / RG 196	082 000 039 101 000
Socket Contact straight	122 346 004 207 000	50	RG 174 / RG 188 / RG 316	082 000 039 102 000
Socket Contact straight	122 346 006 207 000	50	RG 122 (2ZCY 0.4/2.5-75 Ω)	082 000 039 104 000
Socket Contact straight	122 346 008 207 000	50	RG 58	082 000 039 106 000
Socket Contact straight	122 346 010 207 000	50	RG 223	082 000 039 106 000
Crimp tool for EMI Sleeve	080 000 039 000 000			

2) see page 59

Module 2 Positions for 50 Ω Coax-Contacts in the clip principle - SMA Termination

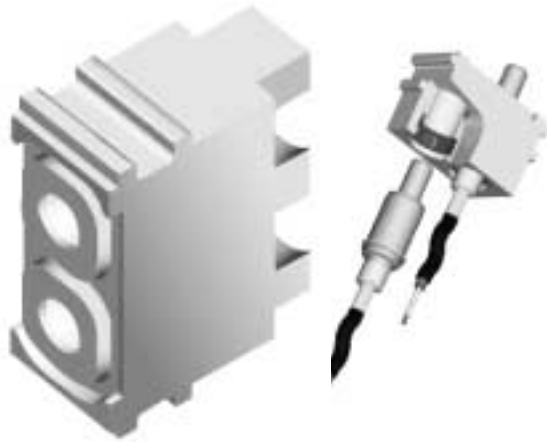

Frequency range: 0-9 GHz
Current Information acc. MIL ²⁾
 Reference Voltage: 350 V
 Test Voltage: 1050 V

Insulation resistance: >100 GΩ
 Total Mating Force (Average): 9 N (32 oz.)/Module
 Total Demating Force (Average): 7,5 N (26 oz.)/Module

Materials:

Insulation Body: Glass-filled thermoplastic (Polyester), UL-94 V0 rated
 Contact Body: Cu-Alloy
 Contact Spring: CuSn

Contact Finish:

Pin, center contact: 0,75 μm Au over 1,25 μm Ni (30 μm Au over 50 μm Ni)
 Pin, outer contact: 6 μm Ni (240 μm Ni)
 Socket, center contact: Springs 0,75 μm Au over 1,25 μm Ni (30 μm Au over 50 μm Ni)
 Socket, outer contact: Springs 0,75 μm Au over 1,25 μm Ni (30 μm Au over 50 μm Ni)
 Operating Temperature: -40°C up to +125°C

Module, Pin and Socket, 2 Positions

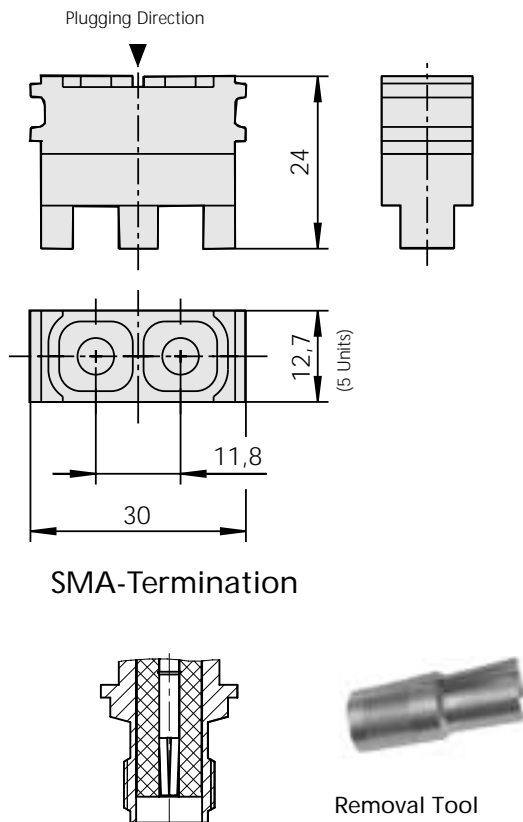

High frequency characteristics of the 50 Ω Coaxial Contacts

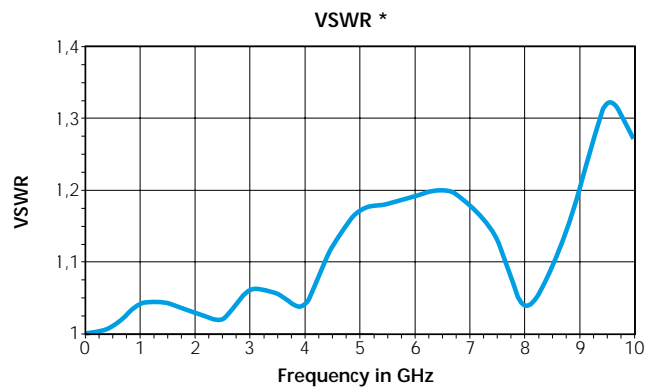
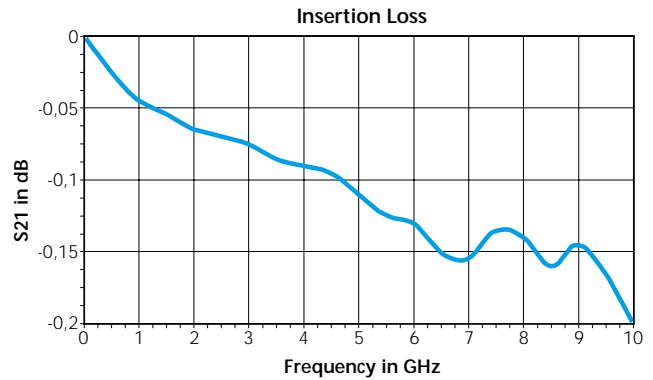

*Voltage standing wave ratio

	Part Number	Termination Style	Cable Impedance (Ω)	
Insulation Body	611 152 102 923 000			
Spacer	611 129 111 923 000			
Dummy Contact	021 341 177 300 000			
Removal Tool	087 122 349 000 000			
Pin Contact straight	122 349 001 207 000	SMA	50	
Socket Contact straight	122 349 002 207 000	SMA	50	

²⁾ see page 59

**Module 2 Positions
for 50 Ω Coax-Contacts
in the clip principle - high voltage**



Frequency range: 0 - 0,25 GHz
Current Information acc. MIL 2)
 Reference Voltage: 850 V
 Test Voltage: 2600 V

Insulation resistance: >100 GΩ
 Total Mating Force (Average): 9 N (32 oz.)/Module
 Total Demating Force (Average): 7,5 N(26 oz.)/Module

Materials:
 Insulation Body: Glass-filled thermoplastic (Polyester), UL-94 V0 rated
 Contact: CU-Aloy
 Surface: 2 μm white bronze + 0,8 μm Au (80 μ" white bronze + 32 μ" Au)

Operating Temperature: -40°C up to +125°C

Module, Pin and Socket, 2 Positions

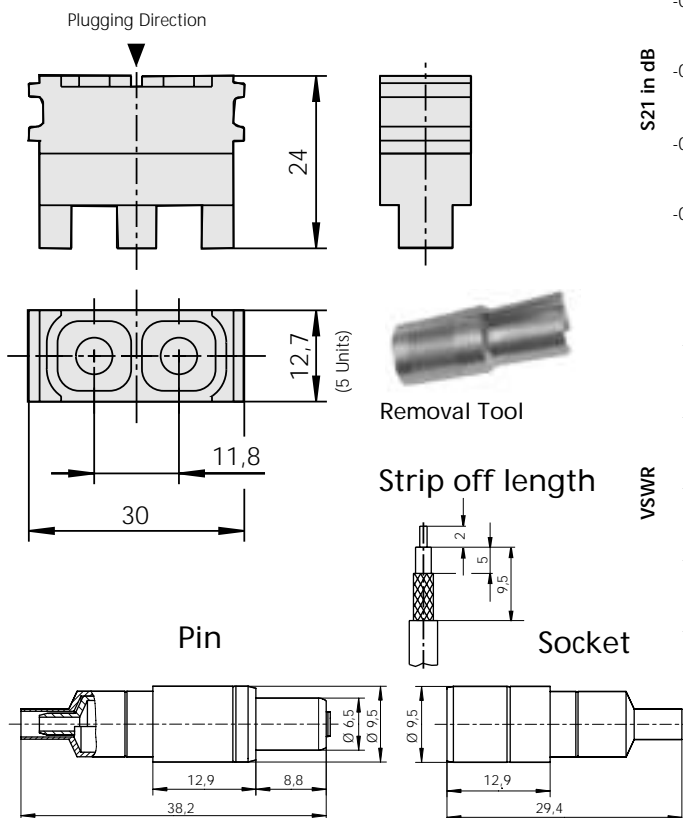

High frequency characteristics of the 50 Ω Coaxial Contacts

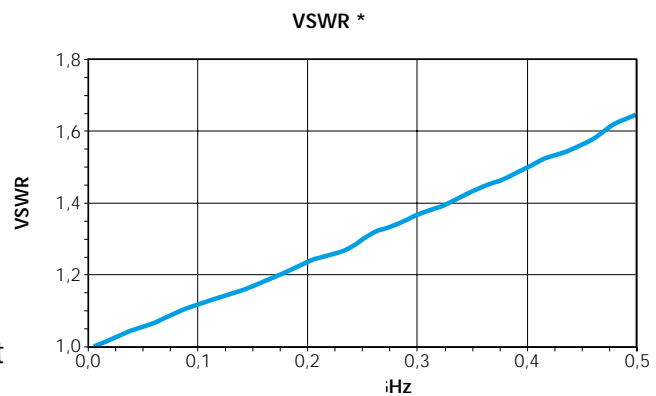
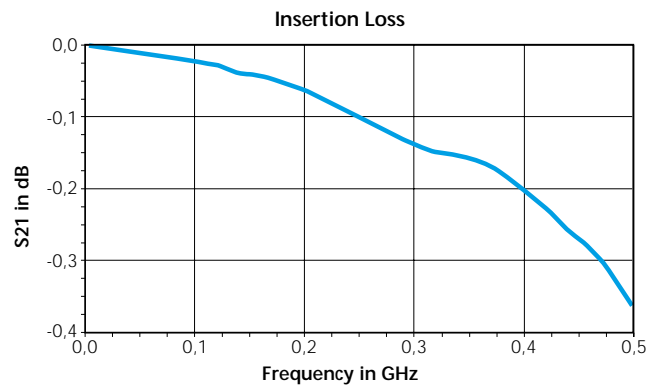

*Voltage standing wave ratio

Center contact - soldered
 Outer contact - soldered or crimped

	Part Number	Coax Cable	
Insulation Body 2 Positions	611 155 102 923 000		
Spacer	611 129 111 923 000		
Dummy contact	021 341 177 300 000		
Removal Tool	087 170 391 000 000		
Pin Contact*	122 126 001 257 000	RG 178 / RG 196	
Pin Contact*	122 126 003 257 000	RG 174 / RG 188 / RG 316	
Pin Contact*	122 126 009 257 000	RG 223	
Socket Contact*	122 126 002 257 000	RG 178 / RG 196	
Socket Contact*	122 126 004 257 000	RG 174 / RG 188 / RG 316	
Socket Contact*	122 126 010 257 000	RG 223	

* Contacts non magnetic 2) see page 59

Module 2 Positions
for 50 Ω Coax-Contacts
(old version)*

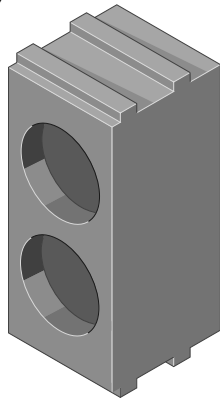

Frequency range: 0-2,5 GHz
Current Information acc. MIL 2)
 Reference Voltage: 400 V
 Test Voltage: 1200 V

Insulation resistance: >100 G Ω
 Total Mating Force (Average): 9 N (32 oz.)/Module
 Total Demating Force (Average): 7,5 N (26 oz.)/Module

Materials:
 Insulation Body: Glass-filled thermoplastic (Polyester), UL-94 V0 rated
 Contact Body: Cu-Alloy
 Contact Spring: CuSn

Contact Finish:
 Pin, center contact: 0,75 μm Au over 1,25 μm Ni (30 μ" Au over 50 μ" Ni)
 Pin, outer contact: 6 μm Ni (240 μ" Ni)

Socket, center contact: Springs 0,75 μm Au over 1,25 μm Ni (30 μ" Au over 50 μ" Ni)

Socket, outer contact: Springs 0,75 μm Au over 1,25 μm Ni (30 μ" Au over 50 μ" Ni)

Operating Temperature: -40°C up to +125°C

Module, Pin and Socket, 2 Positions

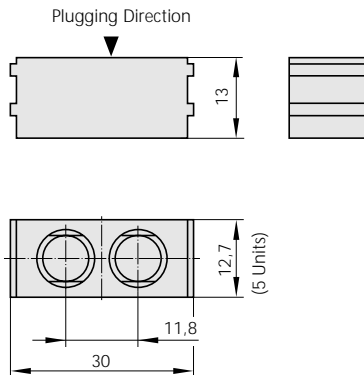

High frequency characteristics of the 50 Ω Coaxial Contacts

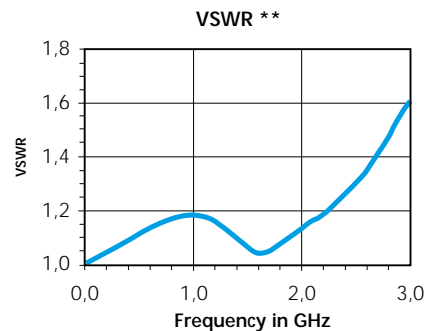
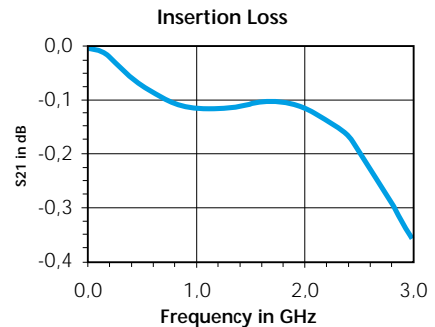

Strip off length

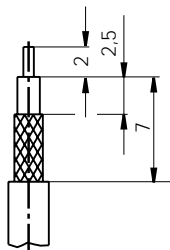

Cable termination

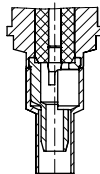

inner conductor soldered
 outer conductor soldered or crimped

* only for replacement
 ** Voltage standing wave ratio

	Part Number.	Cable Impedance (Ω)	Cable (Examples)	Crimp Dies Part Number
Insulation Body 2polig	611 141 102 923 000			
Pin Contact straight	122 331 001 207 000	50	RG 178 / RG 196	082 000 039 101 000
Pin Contact straight	122 333 001 207 000	50	RG 174 / RG 188 / RG 316	082 000 039 102 000
Pin Contact straight	122 335 001 207 000	50	RG 122 (2YCY 0,4/2,5 -75 Ω)	082 000 039 104 000
Pin Contact straight	122 337 001 207 000	50	RG 58	082 000 039 106 000
Socket Contact straight	122 331 002 207 000	50	RG 178 / RG 196	082 000 039 101 000
Socket Contact straight	122 333 002 207 000	50	RG 174 / RG 188 / RG 316	082 000 039 102 000
Socket Contact straight	122 335 002 207 000	50	RG 122 (2YCY 0,4/2,5 -75 Ω)	082 000 039 104 000
Socket Contact straight	122 337 002 207 000	50	RG 58	082 000 039 106 000
Crimp Tool for EMI Sleeve	080 000 039 000 000			

2) see page 59

**Module 2 Positions
for 75 Ω Coax-Contacts in the clip
principle**

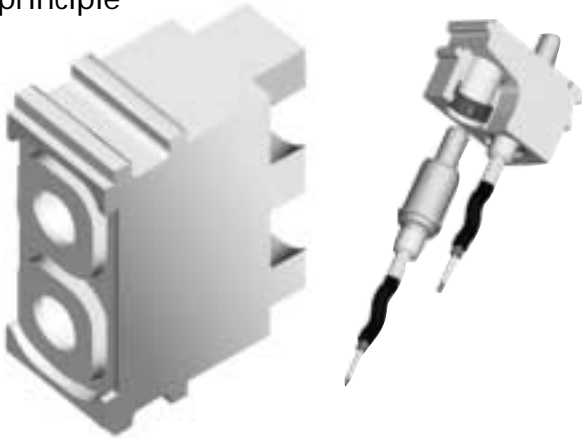

Frequency range: 0-2 GHz
Current Information acc. MIL 2)
 Reference Voltage: 475 V
 Test Voltage: 1425 V

Insulation resistance: >100 G Ω
 Total Mating Force (Average): 9 N (32 oz.)/Module
 Total Demating Force (Average): 7,5 N (26 oz.)/Module

Materials:
 Insulation Body: Glass-filled thermoplastic (Polyester), UL-94 V0 rated
 Contact Body: Cu-Aloy
 Contact Spring: CuSn

Contact Finish:
 Pin, center contact: 0,75 μm Au over 1,25 μm Ni (30 μm Au over 50 μm Ni)
 Pin, outer contact: 6 μm Ni (240 μm Ni)
 Socket, center contact: Springs 0,75 μm Au over 1,25 μm Ni (30 μm Au over 50 μm Ni)
 Socket, outer contact: Springs 0,75 μm Au over 1,25 μm Ni (30 μm Au over 50 μm Ni)
 Operating Temperature: -40°C up to +125°C

Module, Pin and Socket, 2 Positions

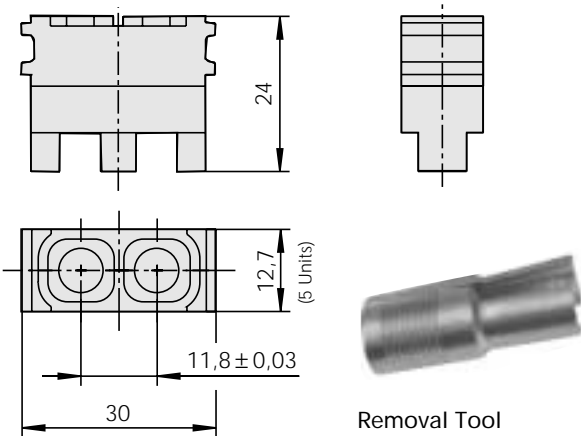

Removal Tool

Strip off length

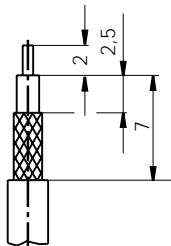

Cable termination

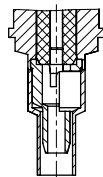

High frequency characteristics of the 75 Ω Coaxial Contacts

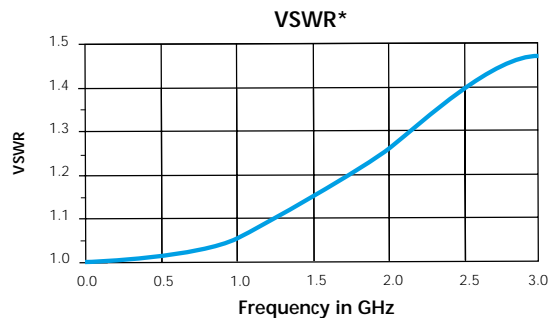
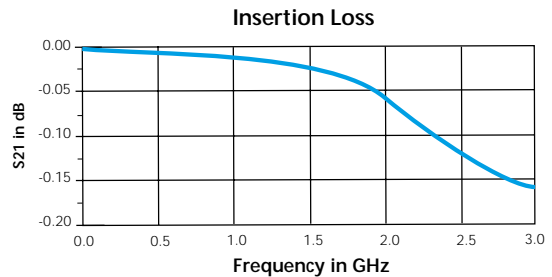

inner conductor soldered
 outer conductor soldered or crimped

*Voltage standing wave ratio

	Part Number.	Cable Impedance (Ω)	Cable (Examples)	Crimp Dies Part Number
Insulation Body	611 155 102 923 000			
Spacer	611 129 111 923 000			
Dummy Contact	021 341 179 923 000			
Removal Tool	087 170 391 000 000			
Pin Contact straight	122 348 003 207 000	75	RG 179 / RG 187	082 000 039 102 000
Pin Contact straight	122 348 007 207 000	75	G 03233 (H+S)	082 000 039 106 000
Pin Contact straight	122 348 009 207 000	75	RG 59	082 000 039 109 000
Socket Contact straight	122 348 004 207 000	75	RG 179 / RG 187	082 000 039 102 000
Socket Contact straight	122 348 008 207 000	75	G 03233 (H+S)	082 000 039 106 000
Socket Contact straight	122 348 010 207 000	75	RG 59	082 000 039 109 000
Crimp tool for EMI Sleeve	080 000 039 000 000			

2) see page 59

Module for 75 Ω Coax-Contacts
(old version)*

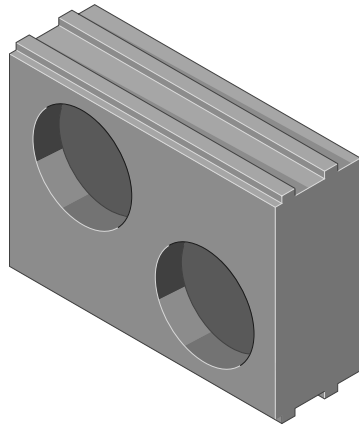

Frequency range: 0 - 500 MHz
Current Information acc. MIL 2)
 Reference Voltage: 650 V
 Test Voltage: 1950 V

Insulation resistance: >100 GΩ
 Total Mating Force (Average): 36 N (130 oz.) (2 Positions)/Module
 18 N (65 oz.) (1 Position)/Module
 Total Demating Force (Average): 30 N (108 oz.) (2 Positions)/Module
 15 N (54 oz.) (1 Position)/Module

Materials:

Insulation Body: Glass-filled thermoplastic (Polyester), UL-94 VO rated

Contact Body: CU-Aloy

Contact Spring: CuSn

Contact Finish:

Pin, center contact: 6 μm Ag (240 μ" Ag)
 Pin, outer contact: 6 μm Ni (240 μ" Ni)
 Socket, center contact: Body 6 μm Ag (240 μ" Ag), Springs blank
 Socket, outer contact: Body 6 μm Ni (240 μ" Ni), Springs blank
 Operating Temperature: -40°C up to +125°C

Socket Module, 2 Pos.

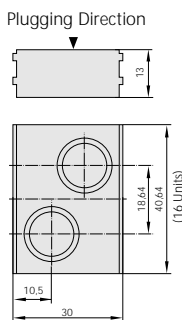

Pin Module, 2 Pos.

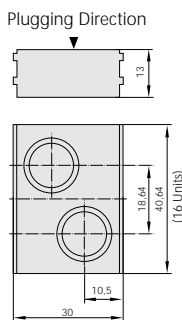

Module, 1 Pos.
(Pin and Socket)

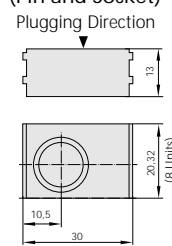

High frequency characteristics of the 50 Ω Coaxial Contacts

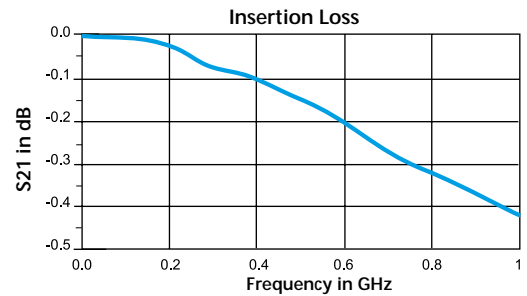

Termination Style:

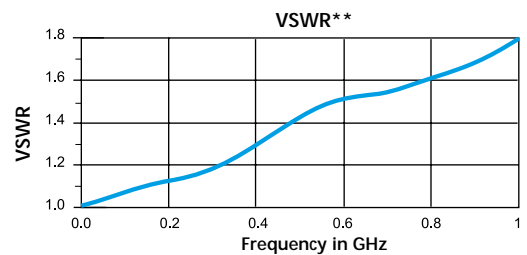
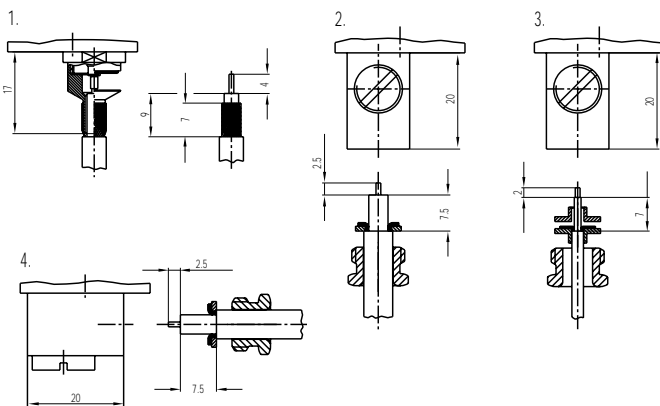

* only for replacement
 ** Voltage standing wave ratio

	Part Number.	Termination Style	Cable Impedance (Ω)	Cable	
Socket Module, 2 Positions	610 140 102 923 000				
Pin Module, 2 Positions	611 140 102 923 000				
Module (Socket & Pin) 1 Position	611 142 101 923 000				
Pin Contact	122 039 001 201 000	1	75	RG 59	
Pin Contact	122 039 003 201 000	2	75	RG 59	
Pin Contact	122 039 006 201 000	3	75	RG 179	
Pin Contact	122 038 003 201 000	4	75	RG 59	
Socket Contact	122 039 002 200 000	1	75	RG 59	
Socket Contact	122 039 004 200 000	2	75	RG 59	
Socket Contact	122 039 007 200 000	3	75	RG 179	
Socket Contact	122 038 004 200 000	4	75	RG 59	
Assembly Tool	122 098 101 704 000				

2) see page 59

Module for compressed air valve
Tube Ø max. 4 mm

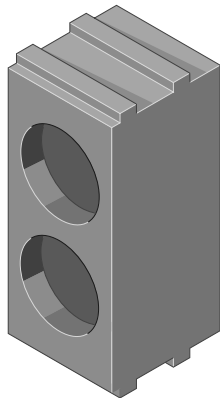

Materials:
 Insulation Body: Glass-filled thermoplastic (Polyester), UL-94 V0 rated
 Compressed Air Valve: CU-Aloy – blank
 Air Pressure: shut off max. 4 bar
 not shut off max. 6 bar
 Operating Temperature: -40°C up to +125°C

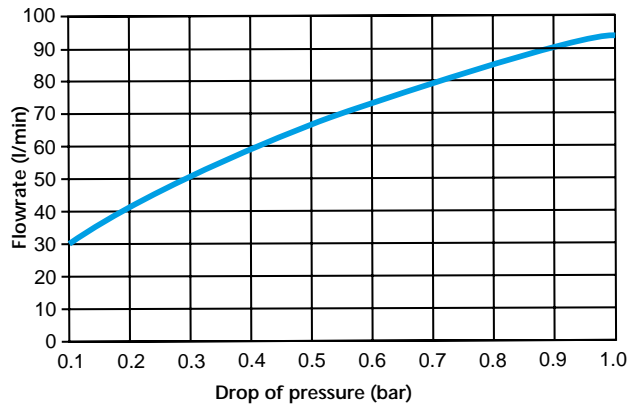

Module, Pin and Socket, 2 Positions

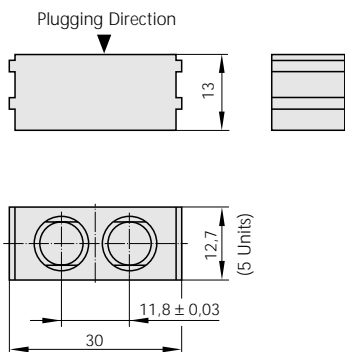

Plug sleeve (Pin)

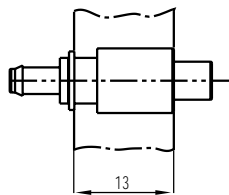

Coupling plug (Socket)

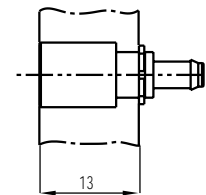

For different kind of termination:

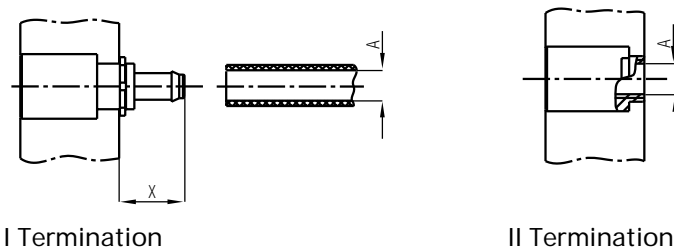

both side "shut off version" on request

	Part Number.	Size A Ø	Size X	Termination	
				I	II
Socket Module, 2 Positions	611 141 102 923 000				
Plug Sleeve (not shut off)	196 023 001 300 000	3	8,5	X	
Plug Sleeve (not shut off)	196 024 001 300 000	4	10,5	X	
Plug Sleeve (not shut off)	196 025 001 300 000	M5	-		X
Coupling Plug (not shut off)	196 023 003 300 000	3	8,5	X	
Coupling Plug (not shut off)	196 024 002 300 000	4	10,5	X	
Coupling Plug (not shut off)	196 025 003 300 000	M5	-		X
Plug sleeve (shut off)	196 025 014 300 000	M5	-		X
Coupling Plug (shut off)	196 023 002 300 000	3	8,5	X	
Coupling Plug (shut off)	196 024 002 300 000	4	10,5	X	
Coupling Plug (shut off)	196 025 012 300 000	M5	-		X

Module for compressed air valve
Tube Ø max. 6 mm

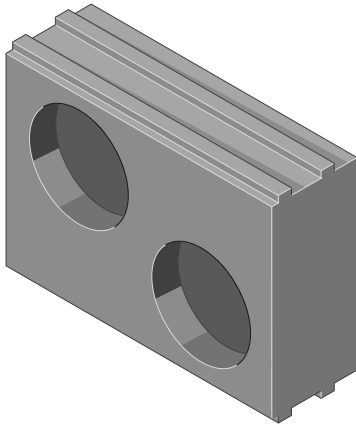

Materials:

Insulation Body:

Glass-filled thermoplastic
(Polyester) UL-94 V0 rated

Compressed Air Valve:

Cu-Alloy

Contact Finish:

blank

Air Pressure:

shut off max. 4 bar

not shut off max. 6 bar

Operating Temperature:

-40°C up to 125°C

Socket Module, 2 Pos.

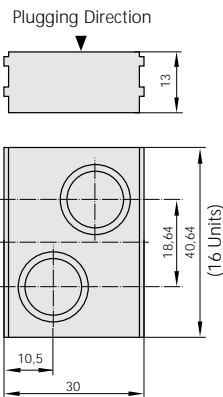

Pin Module, 2 Pos.

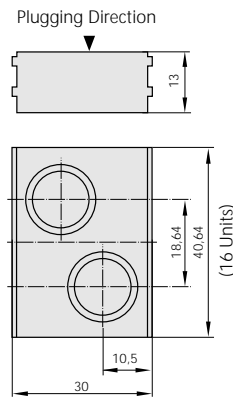

Module, 1 Pos.
(Pin and Socket)

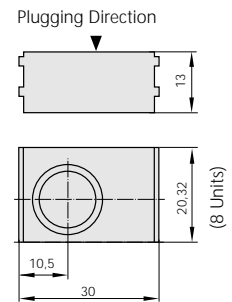

Couplin plug

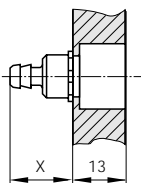

Plug sleeve

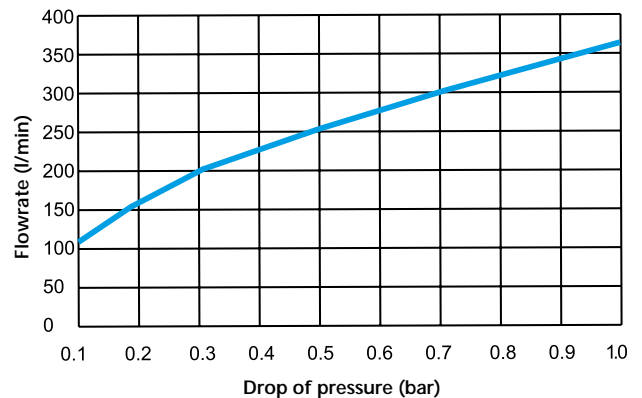
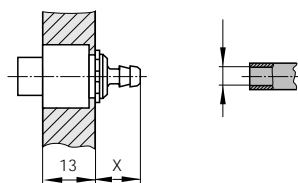

both side "shut off version" on request

	Part Number.	Size A Ø	Size X		
Socket Module, 2 Positions	610 140 102 923 000				
Pin Module, 2 Positions	611 140 102 923 000				
Module (Socket & Pin) 1 Position	611 142 101 923 000				
Plug Sleeve (not shut off)	196 001 001 300 000	4	15		
Plug Sleeve (not shut off)	196 002 001 300 000	6	17,5		
Coupling Plug (not shut off)	196 001 003 300 000	4	15		
Coupling Plug (not shut off)	196 002 003 300 000	6	17,5		
Coupling Plug (shut off)	196 001 002 300 000	4	15		
Coupling Plug (shut off)	196 002 002 300 000	6	17,5		

Module 2 Positions for Fiber Optic Contacts for 1 mm POF (Polymer-Optical-Fiber) with 2.2 / 2.3 mm outer diameter

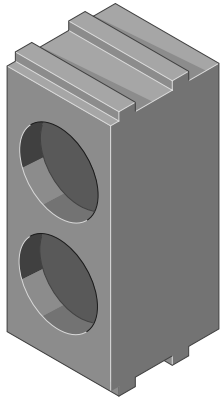
Insertion loss:

typical: 1.5dB at 670nm
 during lifetime: < 2dB at 670nm

Mating cycles: > 100.000
 Total Mating Force (Average): 12N (44 oz.)

Materials:

Insulation Body: Glass-filled thermoplastic (Polyester) UL-94 V0
 Fiber Optical Contact: Cu-Ni-Zn Alloy
 Type of Optical Fiber: Polymer-Optical-Fiber (POF) 980/1000 or 980/1550
 Fiber fastening: Clamping

Temperature range:

standard Fiber: -40°C/+85°C
 high Temperature fiber: -40°C/+115°C

Module, Pin and Socket, 2 Positions

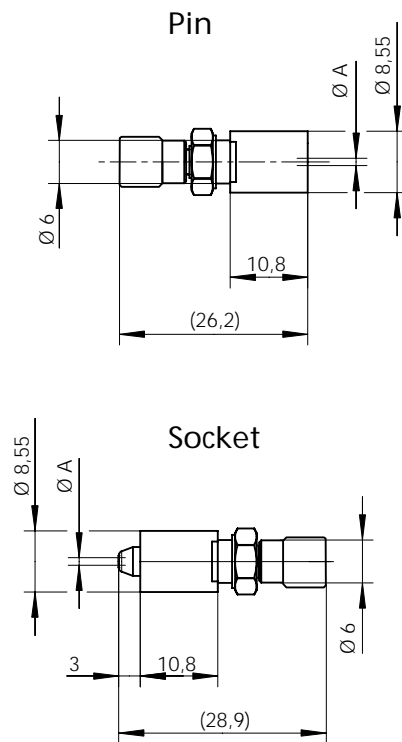
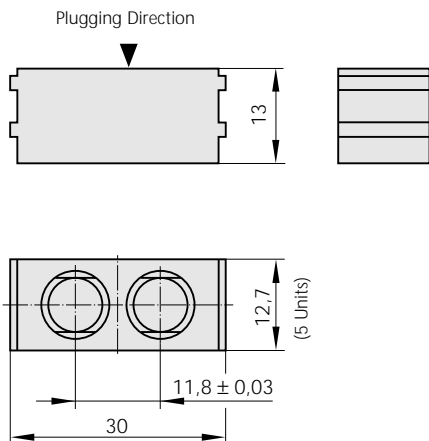

Assembly:

Please ask for the assembly instruction.

	Part Number.	Maß A	
Module, 2 Positions	611 141 102 923 000		
Socket 980/1000 µm	196 501 001 901 000	1,05	
Plug 980/1000 µm	196 501 002 901 000	1,02	
Socket 980/1550 µm (MOST standard)	196 502 001 901 000	1,60	
Plug 980/1550 µm (MOST standard)	196 502 002 901 000	1,60	
Tool for cable-stripping	598 501 001 000 000		
Wrench/Spanner 4,5 mm	598 501 002 000 000		
Wrench/box spanner 8 mm	598 501 003 000 000		
Polish-device for jack	598 501 004 000 000		
Spare blades	598 501 005 000 000		
Polish-device for plug	598 501 007 000 000		
Sandpaper 1000	598 501 008 000 000		
Polishfleece	598 501 009 000 000		
Polish for acrylic glass	598 501 005 000 000		

Fiber optical contact for glass fiber on request

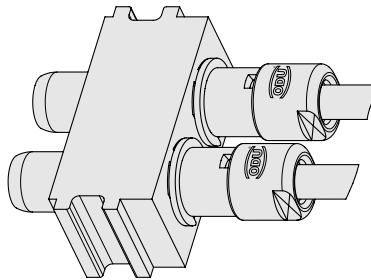
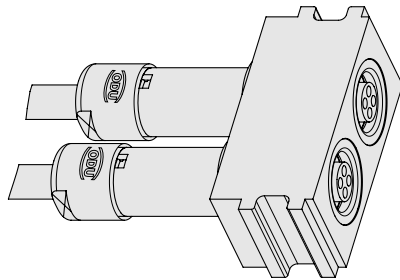
Module for multiposition, shielded implementation (Application in Bussystems)



We get data rates from up to 400 Mbit/s according to IEEE 1394-1995. with our inserts.
The application in the following systems includes this module:

- Profibus
- Interbus
- P-Net
- CAN-Bus

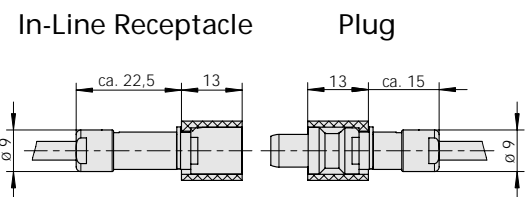
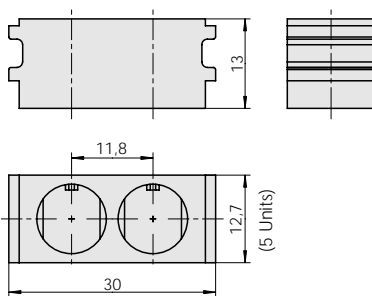

Part Numbers:

Basis Parts:

- ① Insulation body: 611 148 102 923 000
- ② Cable housing cpl.: 653 001 001 304 000
- ② Plug housing cpl.: 653 001 002 304 000

③/4 Inserts cpl. – Solder-in Version

Inserts

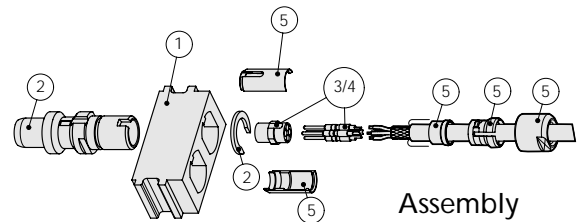
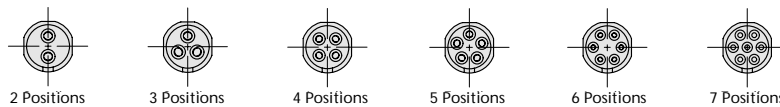

Pos.	Contact Ø	Application cross section	Rated voltage Rated impulse voltage Degree of Pollution up to VDE 110	Test Voltage acc. to VDE 0627	Version	Insert cpl. Part number
2pol.	0,9	AWG 22	32 V/2KV/3 100V/2 KV/2	875 VAC	St	700 849 720 002 200
					Bu	700 749 720 002 200
3pol.	0,9	AWG 22	10V/1,5KV/3 32 V/1,5 KV/2	875 VAC	St	700 849 720 003 200
					Bu	700 749 720 003 200
4pol.	0,7	AWG 26	10V/1,5KV/3 32V/1,5KV/2	875 VAC	St	700 848 720 004 200
					Bu	700 748 720 004 200
5pol.	0,7	AWG 26	10V/1,5KV/3 32V/1,5KV/2	750 VAC	St	700 848 720 005 200
					Bu	700 748 720 005 200
6pol.	0,5	AWG 28	10V/1,5KV/3 32 V/1,5 KV/2	750 VAC	St	700 841 720 006 200
					Bu	700 741 720 006 200
7pol.	0,5	AWG 28	10V/1,5KV/3 32 V/1,5 KV/2	750 VAC	St	700 841 720 007 200
					Bu	700 741 720 007 200

Only Inserts -Crimp termination
(on request)

⑤ Assembly Set

Cabel Ø	Part number
1,5-2,0 mm	653 001 001 304 020
2,0-2,5 mm	653 001 001 304 025
2,5-3,0 mm	653 001 001 304 030
3,0-3,5 mm	653 001 001 304 035
3,5-4,0 mm	653 001 001 304 040
4,0-4,5 mm	653 001 001 304 045
4,5-5,0 mm	653 001 001 304 050

Strip off lenght

Contact Ø	Solder term.		
	L	A	S
0,5	7	2	2,5
0,7	7	2	2,5
0,9	7	2	2,5

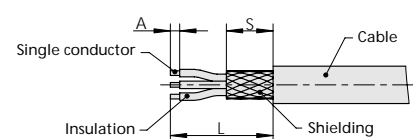

Alignment Requirements between Surface B and Surface S for Standard version

The values are for connectors in mated condition and are determined by the float in the guide bushings.

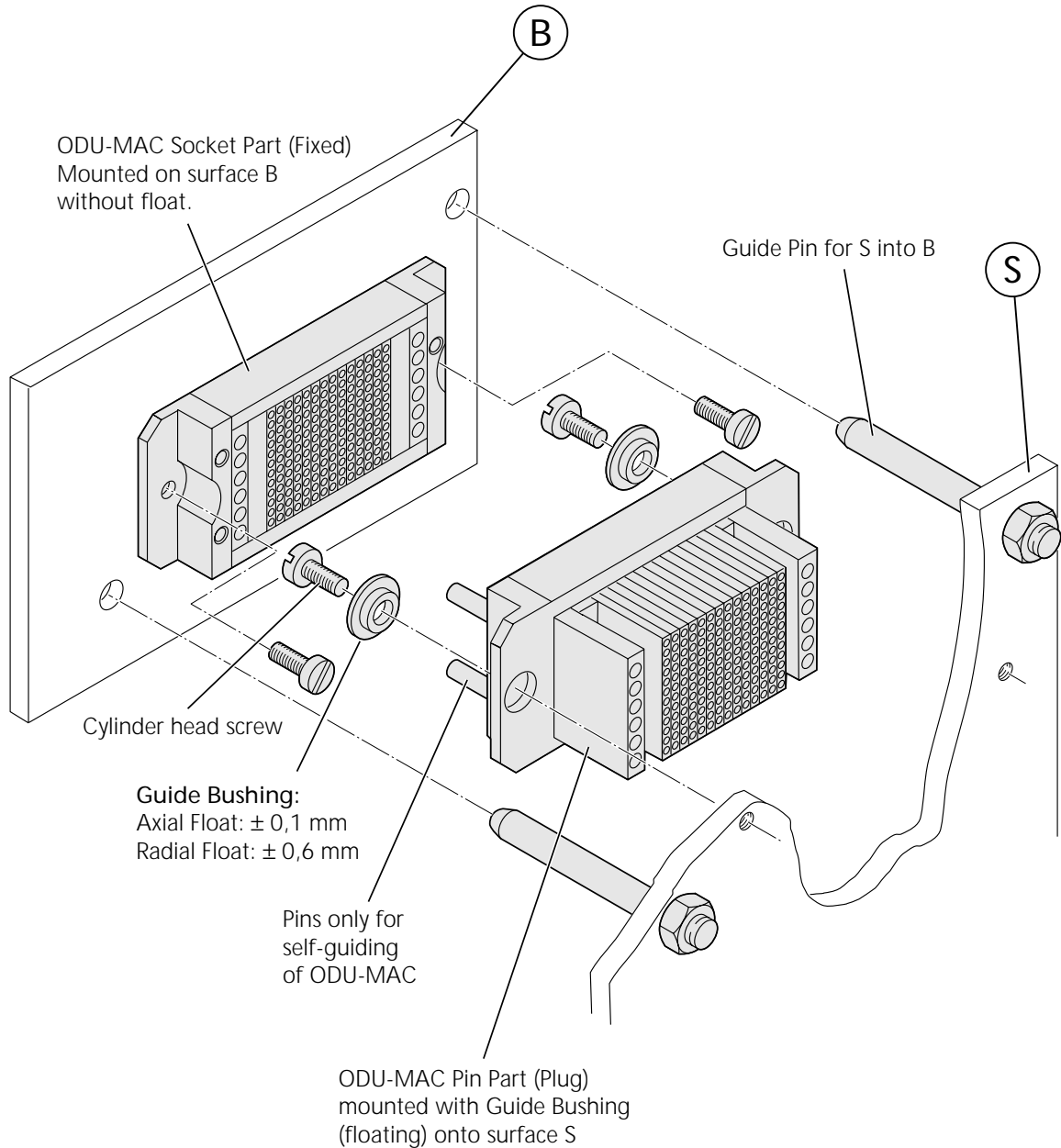

ODU MAC-L Aluminum Frame
 Special Design with longer guide pins and -bushes
 for higher mating cycles and bigger radial offset.

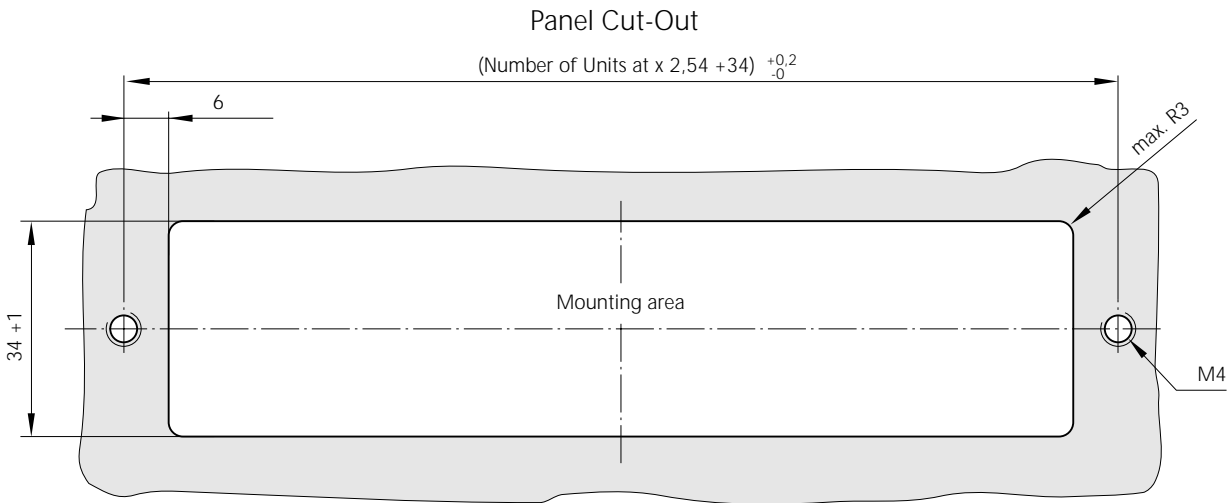

Guide Plane

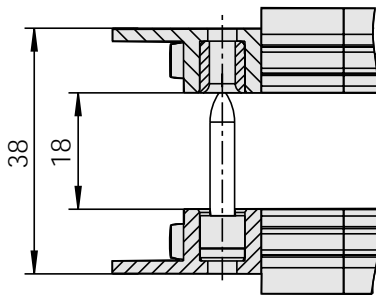

Contact Plane

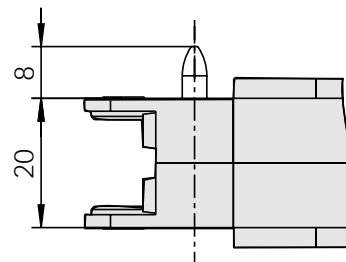

Axial tolerances 0.4 mm, Radial tolerances ± 1.2 mm

Application Example

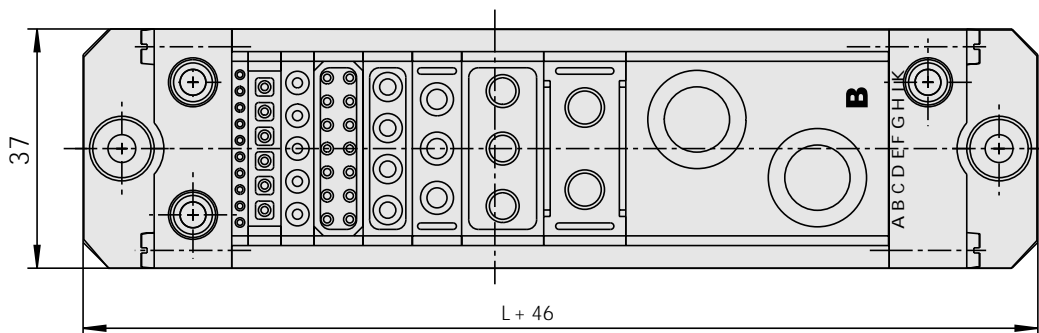

	Part Number.	Additional Ordering Information
Pin Frame (Plug)	611 009 OXX 600 000	Dim. L = Numbers of units x 2.54.
Frame for Sockets (Receptacle)	610 009 OXX 600 000	XX = Denotes number of units

32 Keying Positions possible - please request

ODU MAC-M Frame for Pins (Plug)
for reduced layout

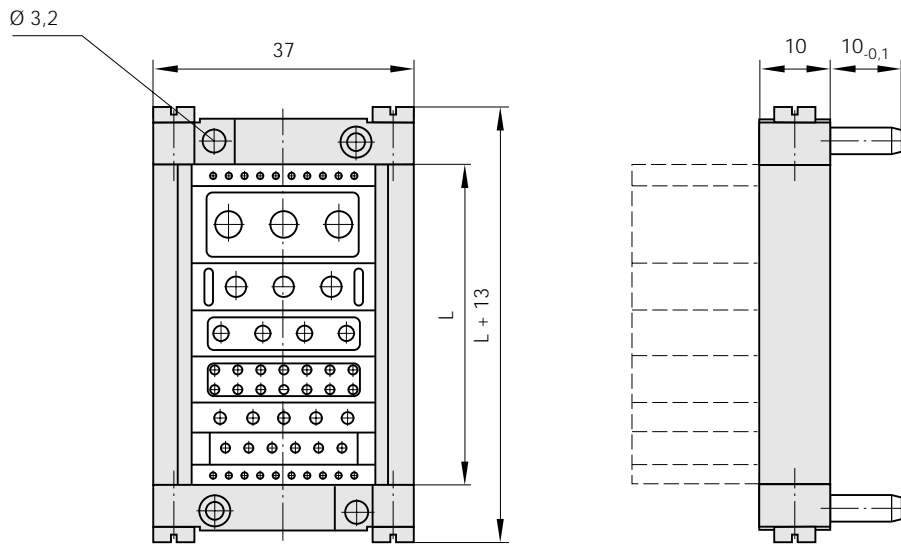

	Part Number.	Additional Ordering Information
Pin Frame (Plug)	611 017 0XX 600 000	Dim. L = Number of units x 2.54, XX = Denotes number of units

ODU MAC-M Frame for Sockets (Receptacle)
for reduced layout

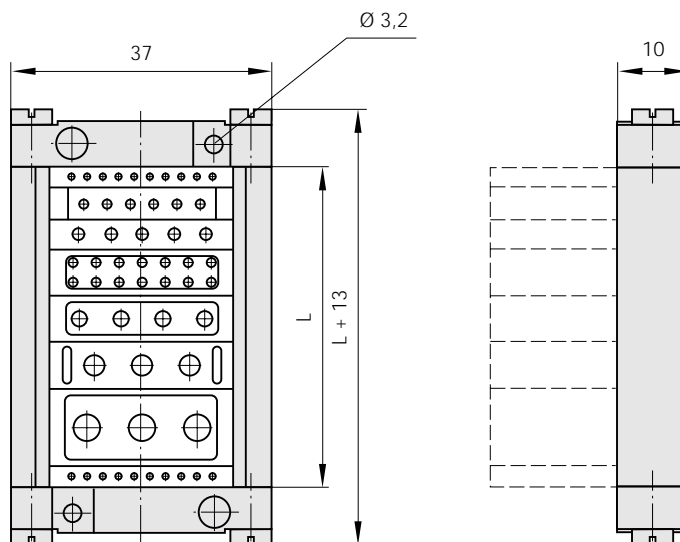

	Part Number.	Additional Ordering Information
Frame for Sockets (Receptacle)	610 017 0XX 600 000	Dim. L = Number of units x 2.54 mm XX = Denotes number of units

For your notes:

For your information

We have modified the ODU MAC DIN frames and, in particular, improved the stability. For this reason, the sheet steel that had been used previously has been replaced with aluminum.

The new solid sockets do not fit on the "old" DIN pin frames (that means that, in this case, there is no backward compatibility). You can continue to purchase the "old" version of the frame from us.

You will find a catalog excerpt of the old versions with the corresponding order numbers in the Internet at: www.odu.de → Download Center → MAC → Catalogue excerpt old version (sheet steel frame).

I NEW



ODU MAC in DIN housing (white) with solid frame

II OLD



ODU MAC in DIN housing with steel sheet frame

	Male part „old“ (steel sheet frame)	Male Part „new“ (solid frame)
Female part „old“ (steel sheet frame)	✓	✓
Female part „new“ (solid frame)	✗	✓

ODU-MAC frame for DIN housing
with grounding termination

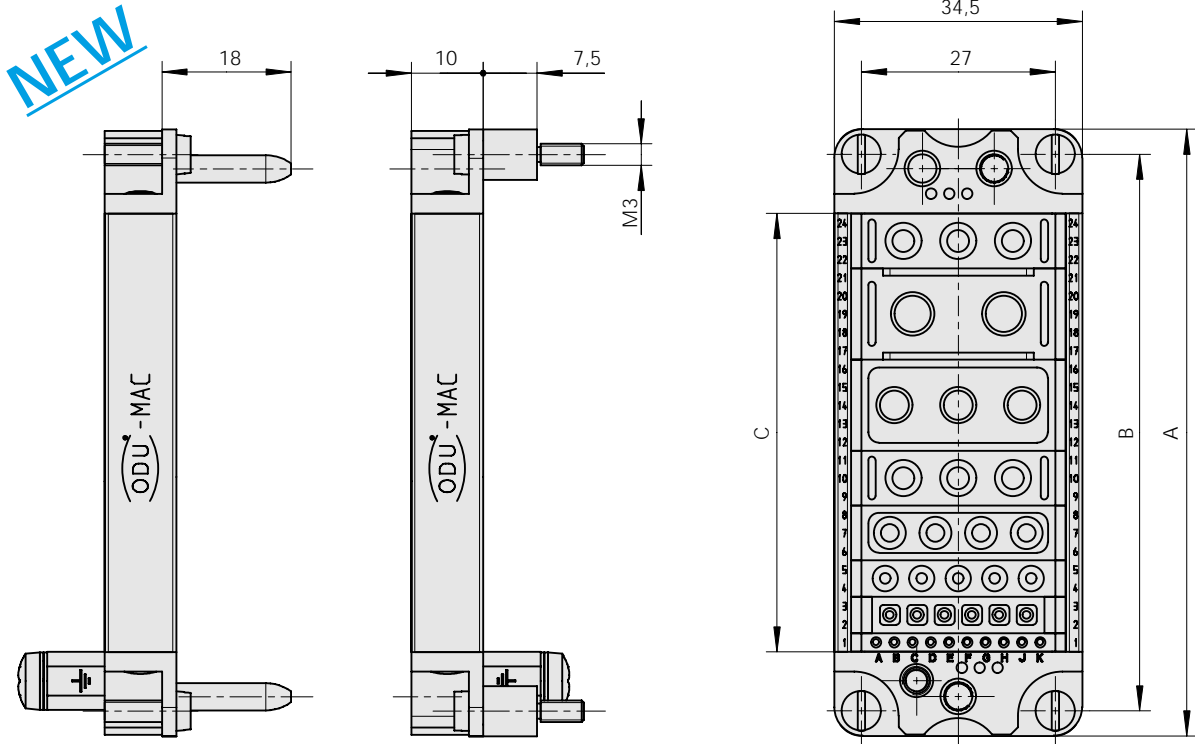

Coding forms see page 37

Sockets (Receptacle) in Panel-Mounted or
Box-Mounted Base
Pins (Plug) in Cable Hood

Delivery without modules

Size	Part Number. for socket frame	Part Number. for pin frame	max. Units à 2,54 mm ODU MAC	Dim. A	Dim. B	Dim. C
1	610 190 000 600 000	611 190 000 600 000	10	51	44	25,5
2	610 191 000 600 000	611 191 000 600 000	16	64	57	40,8
3	610 192 000 600 000	611 192 000 600 000	24	84,5	77,5	61,1
4	610 193 000 600 000	611 193 000 600 000	34	111	104	86,5

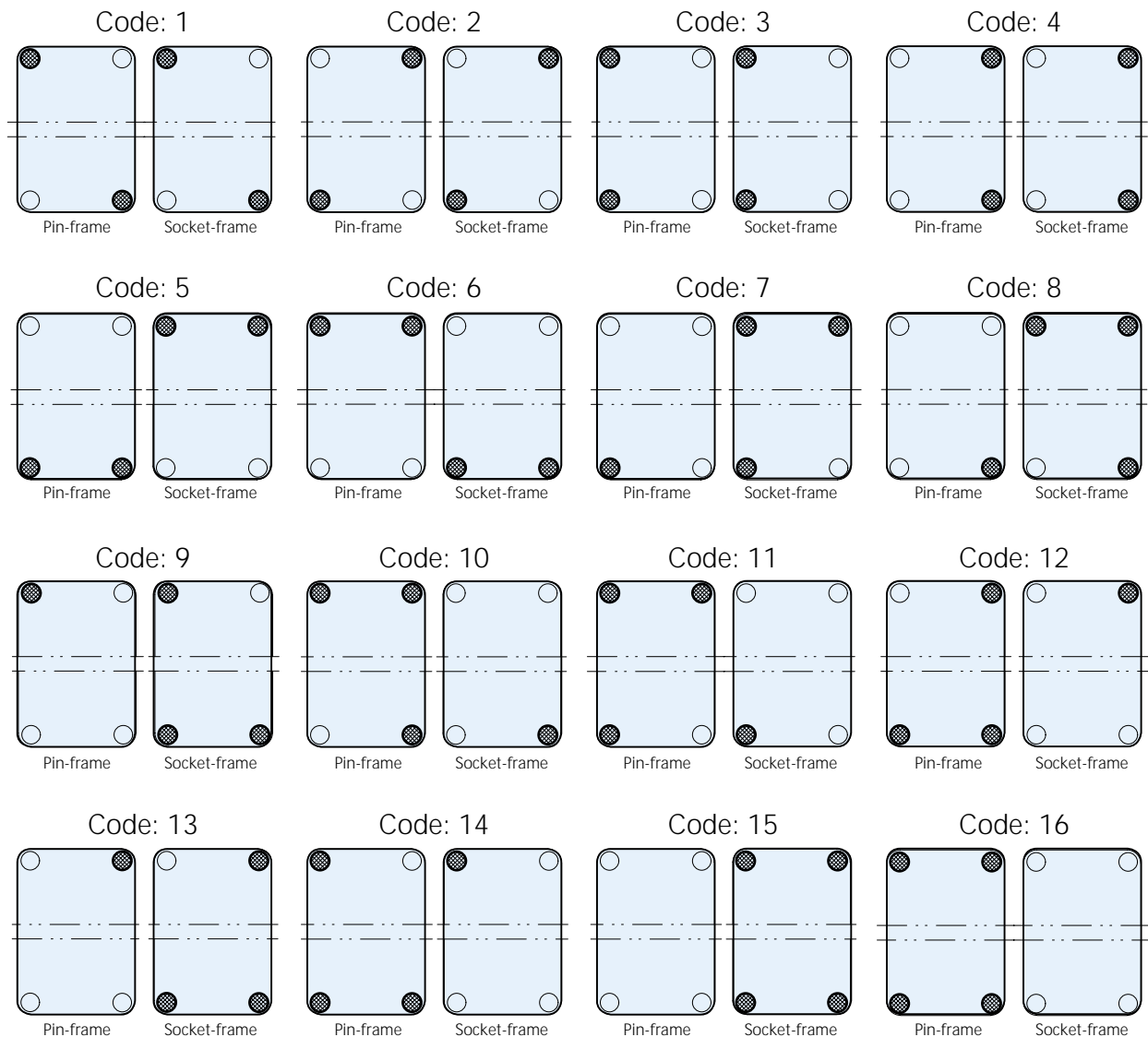

Housings see page 38-44

Coding forms for solid frame in DIN housing
(Page 36)



Coding on special order!

Replace the cylinder head screw with the coding socket or coding pin

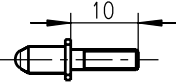
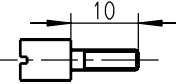
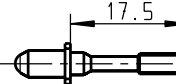
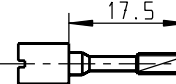
Frame	Coding	
	 Pin	 Socket
611 19. 000 600 000	611 090 301 704 000 	610 090 302 704 000 
610 19. 000 600 000	611 090 302 704 000 	610 090 301 704 000 

ODU MAC DIN Housing
Panel-Mounted Base including lever locking
 (standard colour of housing: grey)

NEW

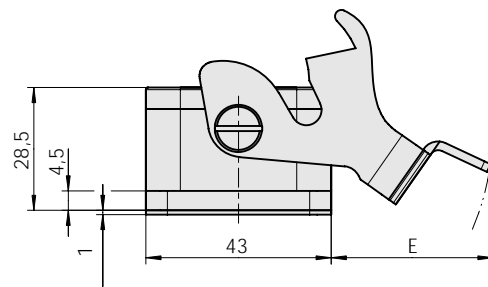
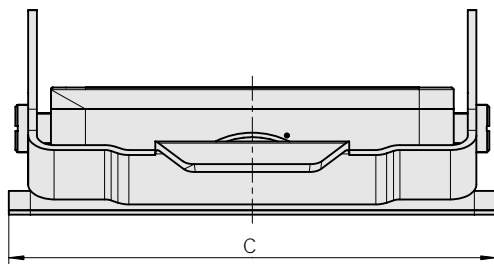

Panel Cut-Out

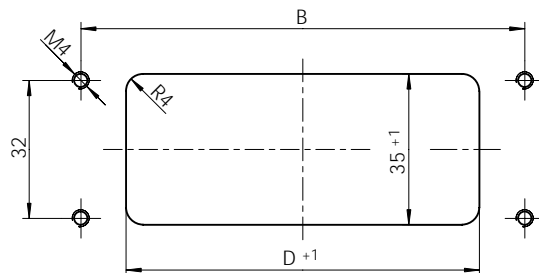
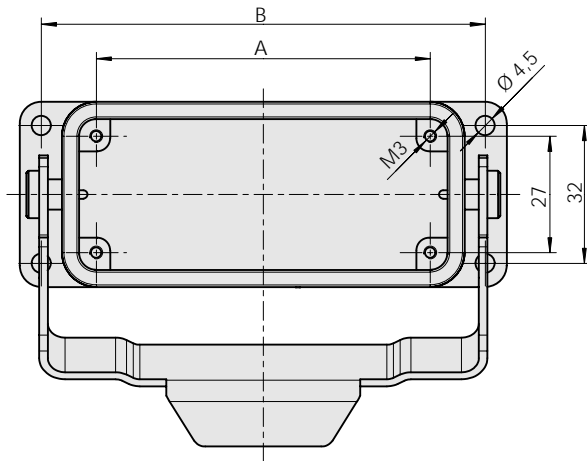

Cover on request!

Size	Part Number. Panel-Mounted Base	Dim. A	Dim. B	Dim. C	Dim. D	Dim. E
1	490 130 400 644 000	44	70	80	48	ca. 25
2	491 130 400 644 000	57	83	93	60	ca. 35
3	492 130 400 644 000	77.5	103	113	82	ca. 35
4	493 130 400 644 000	104	130	140	108	ca. 35

ODU MAC DIN Housing
Cable Hood - with straight or right angled exit for lever locking

NEW



Straight exit

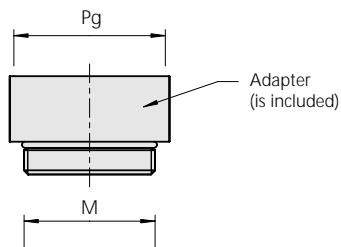

Part Number Adapter

Exit M	with adapter Exit PG	Part number
M25 x 1,5	PG 21	921 000 006 000 254
M32 x 1,5	PG 29	921 000 006 000 255

Right angled exit

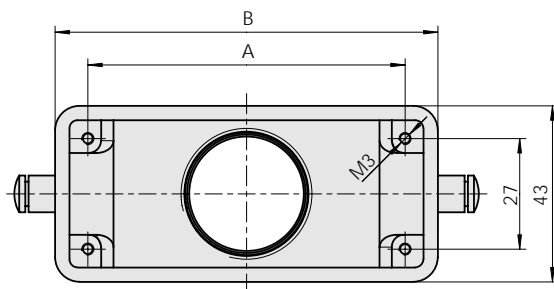
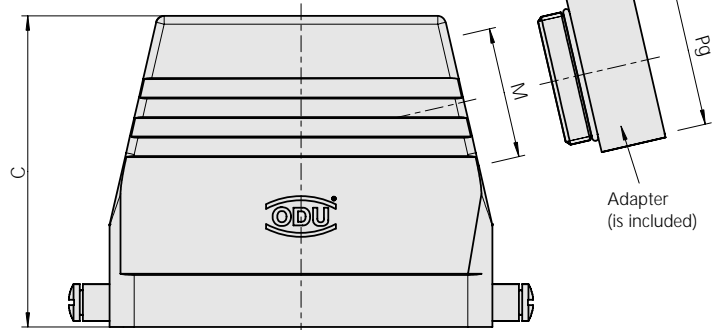
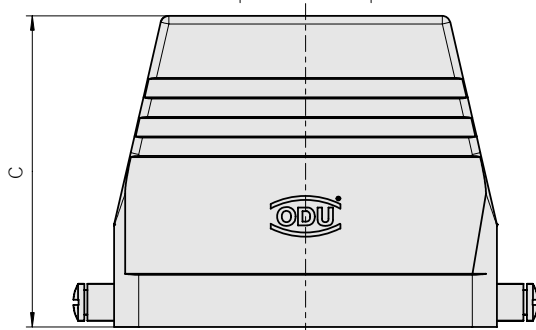

Cable gland see page 43.

Größe	Part Number Cable Hood Right angled exit	Part Number Cable Hood Straight exit	Dim. A	Dim. B	Dim. C	Exit M	Exit PG
1	490 414 450 644 000	490 214 450 644 000	44	60	48	M 25 x 1,5	21
1	490 415 450 644 000	490 215 450 644 000	44	60	70	M 32 x 1,5	29
2	491 414 450 644 000	491 214 450 644 000	57	73	50	M 25 x 1,5	21
2	491 415 450 644 000	491 215 450 644 000	57	73	70	M 32 x 1,5	29
3	492 415 450 644 000	492 215 450 644 000	77,5	93,5	76	M 32 x 1,5	29
4	493 415 450 644 000	493 215 450 644 000	104	120	78	M 32 x 1,5	29

ODU MAC DIN Housing
Box-Mounted Base including lever-locking

NEW

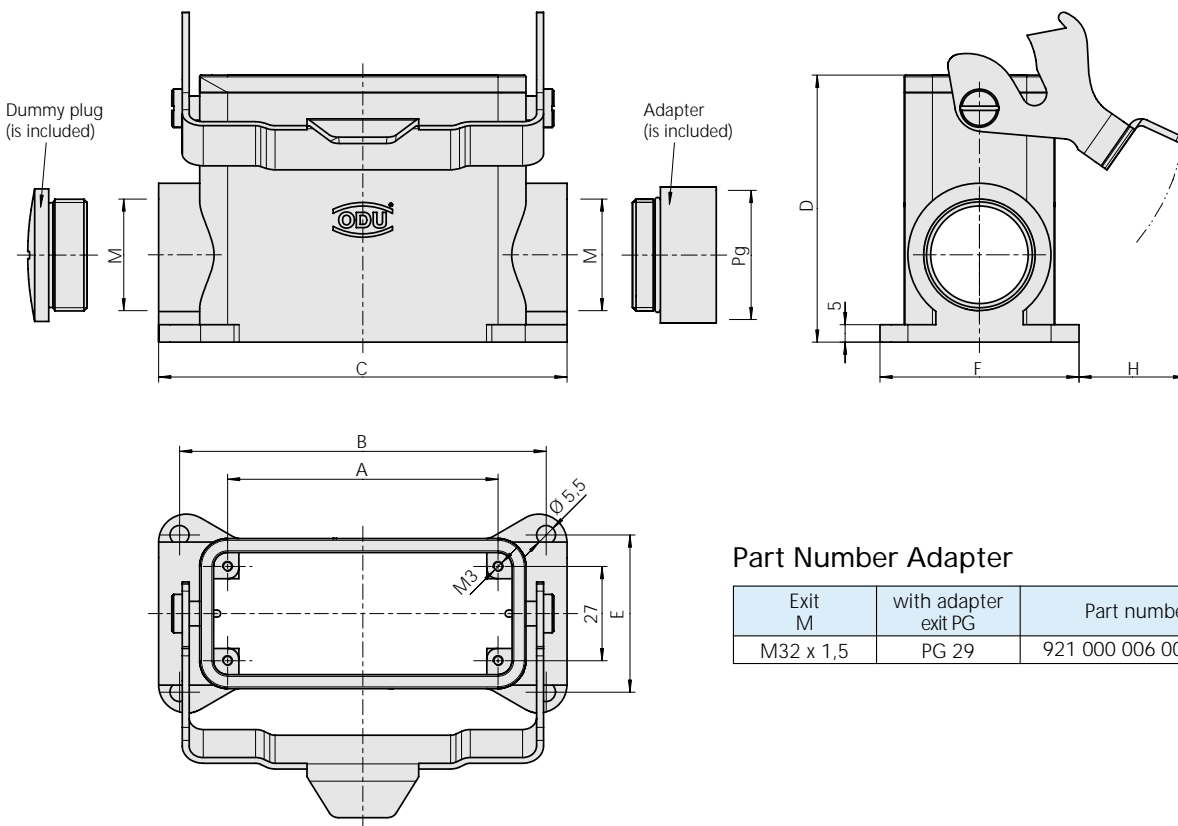

Part Number Adapter

Exit M	with adapter exit PG	Part number
M32 x 1,5	PG 29	921 000 006 000 255

Cover on request

Size	Part number Box-Mounted Base	Dim. A	Dim. B	Dim. C	Dim. D	Dim. E	Dim. F	Dim. H	Exit M	Exit PG
1	490 133 450 644 000	44	70	82	73,5	45	57	ca. 22	M 32 x 1,5	29
2	491 133 450 644 000	57	82	94	73,5	45	57	ca. 30	M 32 x 1,5	29
3	492 133 450 644 000	77,5	105	117	76,5	45	57	ca. 30	M 32 x 1,5	29
4	493 133 450 644 000	104	132	144	78,5	45	57	ca. 30	M 32 x 1,5	29

ODU MAC DIN housing
for Spindle Locking

NEW

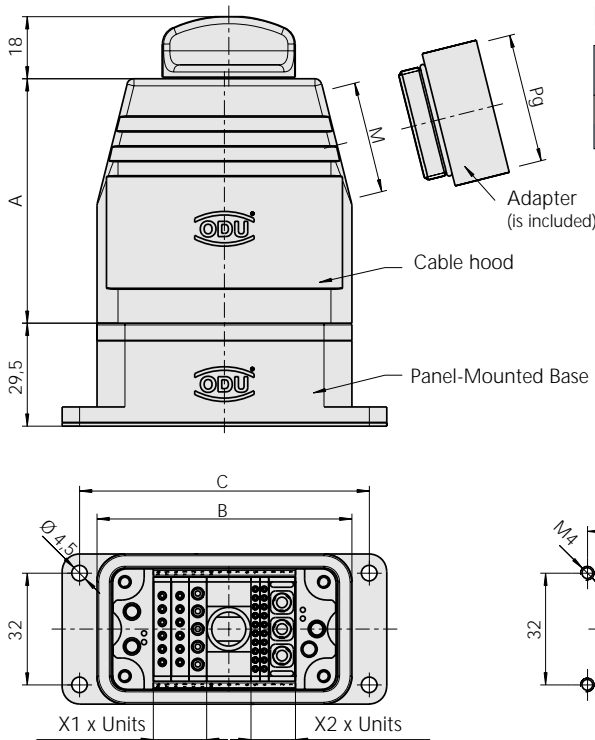

Part number adapter

Exit M	with adapter exit PG	Part number
M25 x 1,5	PG 21	921 000 006 000 254
M32 x 1,5	PG 29	921 000 006 000 255

Panel Cut-Out

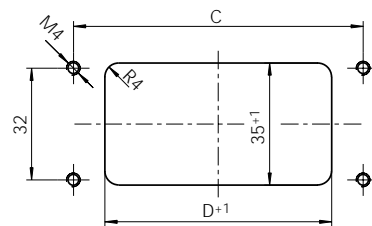

White housing

Cable gland see page 43.

Size	Part Number. Cable hood incl. adapter	Part Number. Panel Mounted Base	Dim. A	Dim. B	Dim. C	Dim. D	X1	X2	Exit M	with adapter Exit PG	Spindle head
2	613 091 513 653 003	612 091 010 653 000	50	73	83	60	6	5	M 25 x 1,5	PG 21	white
2	613 091 514 653 003	612 091 010 653 000	70	73	83	60	6	5	M 32 x 1,5	PG 29	
3	613 092 514 653 003	612 092 010 653 000	76	93,5	103	82	10	9	M 32 x 1,5	PG 29	
4	613 093 514 653 003	612 093 010 653 000	78	120	130	108	15	14	M 32 x 1,5	PG 29	

Grey housing

Size	Part Number. Cable hood incl. adapter	Part Number. Panel Mounted Base	Dim. A	Dim. B	Dim. C	Dim. D	X1	X2	Exit M	with adapter Exit PG	Spindle head
2	613 091 513 644 008	612 091 010 644 000	50	73	83	60	6	5	M 25 x 1,5	PG 21	black
2	613 091 514 644 008	612 091 010 644 000	70	73	83	60	6	5	M 32 x 1,5	PG 29	
3	613 092 514 644 008	612 092 010 644 000	76	93,5	103	82	10	9	M 32 x 1,5	PG 29	
4	613 093 514 644 008	612 093 010 644 000	78	120	130	108	15	14	M 32 x 1,5	PG 29	

ODU-MAC Spindle Locking System, Version 1

For Sockets (Receptacle) in Panel- or Box-Mounted Base and Pins (Plug) in Cable Hood.

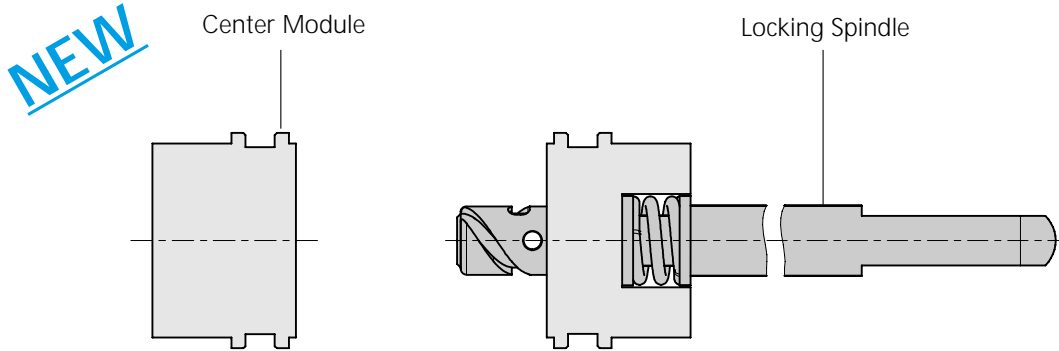

Space requirement: 5 units (5 x 2,54 mm)

Version 1

Size	Center Module for Panel or Box Mounted Base	Locking Spindle in Cable Hood
2	614 090 001 304 000	615 091 003 200 000
3	614 090 001 304 000	615 091 001 200 000
4	614 090 001 304 000	615 092 001 200 000

ODU-MAC Spindle Locking System, Version 2

For Pins (Plug) in Panel- or Box-Mounted Base and Sockets (receptacle) in Cable Hood

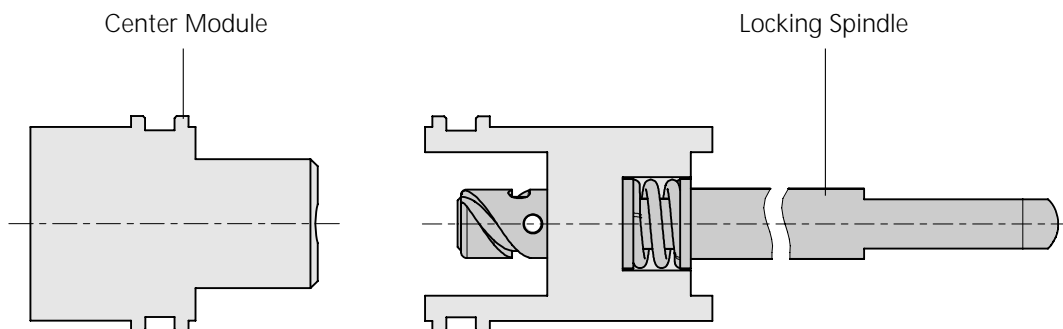

Version 2

Size	Center Module for Panel or Box Mounted Base	Locking Spindle in Cable Hood
2	614 090 002 304 000	615 091 004 200 000
3	614 090 002 304 000	615 091 002 200 000
4	614 090 002 304 000	615 092 002 200 000

Cable gland for DIN housing
(according to EN 50262)

NEU



Temperature:	-40 °C up to +100 °C
Protection class:	IP 68 up to 5 bar
Width across flat:	M25 x 1,5: 30 M32 x 1,5: 36
Starting torque:	M25 x 1,5: 8 Nm M32 x 1,5: 10 Nm

Colour: white (RAL 7035)

Cable-Ø	Part number M 25 x 1.5
6.0 - 13.0	027 825 060 130 003
9.0 - 17.0	027 825 090 170 003

Cable-Ø	Part number M 32 x 1.5
7.0 - 15.0	027 832 070 150 003
11.0 - 21.0	027 832 110 210 003

Colour: gray (RAL 7001)

Cable-Ø	Part number M 25 x 1.5
6.0 - 13.0	027 825 060 130 007
9.0 - 17.0	027 825 090 170 007

Cable-Ø	Part number M 32 x 1.5
7.0 - 15.0	027 832 070 150 007
11.0 - 21.0	027 832 110 210 007

EMV housing

(on request)



Application examples:

Application on demageable interfaces which must be opposed to electromagnetic fields.

Versions:

- electric conductible surface
- internal sealing
- Housing made out of Aluminium-Pressure Casting-Alloy
- Operating temperature: -40°C up to + 125°C

For your notes:

Crimp Instructions

Termination cross section		Contact- Ø	Strip-off length	8 pt. Crimp tool		8 pt. Crimp tool		8 pt. Crimp tool	8 pt. Crimp tool	
AWG	mm ²			080 000 014 000 000	Identification groove	080 000 032 000 000	Identification groove	080 000 037 000 000	080 000 038 000 000	
				Gauge Ø		Gauge Ø		Position no.	Position no.	
				Contact holder		Contact holder		Contact holder	Contact holder	
24/28	0,08/0,25			>0,65 <0,70		>0,65 <0,70		4		
		0,76	4 ^{+0,5}	021 345 151 300 000	0	021 345 151 300 000	0	021 345 151 200 037		
		1,02		021 345 152 300 000	1	021 345 152 300 000	1	021 345 152 200 037		
		1,5		021 345 153 300 000	2	021 345 153 300 000	2	021 345 153 200 037		
26/28		0,7								
22/24		0,7								
22	0,38			>0,65 <0,70		>0,65 <0,70		4		
		0,76	4 ^{+0,5}	021 345 151 300 000	0	021 345 151 300 000	0	021 345 151 200 037		
20/22	0,38/0,50			>0,90 <0,95		>0,90 <0,95		7	2	
		1,02	4 ^{+0,5}	021 345 152 300 000	1	021 345 152 300 000	1	021 345 152 200 037	021 345 152 200 038	
		1,5		021 345 153 300 000	2	021 345 153 300 000	2	021 345 153 200 037	021 345 153 200 038	
		2,41	5 ^{+0,5}	021 345 149 300 000	3	021 345 149 300 000	3		021 345 149 200 038	
3	021 345 150 300 000	4		021 345 150 300 000	4		021 345 150 200 038			
18	1			>1,1 <1,15		>1,1 <1,15			5	
		1,5	4 ^{+0,5}	021 345 153 300 000	2	021 345 153 300 000	2		021 345 153 200 038	
		2,41	5 ^{+0,5}	021 345 149 300 000	3	021 345 149 300 000	3		021 345 149 200 038	
3	021 345 150 300 000	4		021 345 150 300 000	4		021 345 150 200 038			
16				>1,40 <1,45		>1,40 <1,45			6	
		1,5	4 ^{+0,5}	021 345 153 300 000	2	021 345 153 300 000	2		021 345 153 200 038	
14	1,5			>1,40 <1,45		>1,40 <1,45			6	
		1,5	4 ^{+0,5}	021 345 153 300 000	2	021 345 153 300 000	2		021 345 153 200 038	
		2,41	5 ^{+0,5}	021 345 149 300 000	3	021 345 149 300 000	3		021 345 149 200 038	
3	021 345 150 300 000	4		021 345 150 300 000	4		021 345 150 200 038			
12									8	
		2,41	5 ^{+0,5}						021 345 149 200 038	
	2,5			>1,60 <1,65		>1,60 <1,65			7	
		2,41	5 ^{+0,5}	021 345 149 300 000	3	021 345 149 300 000	3		021 345 149 200 038	
		3		021 345 150 300 000	4	021 345 150 300 000	4		021 345 150 200 038	
	4	3	4 ^{+0,5}							
		5	6 ^{+0,5}							
	6	4	6 ^{+0,5}							
	10	5	9 ^{+0,5}							

6 pt. Crimp tool	6 pt. Crimp tool	Hand crimp tool (stamped contacts)	Hand crimp tool for spool (stamped contacts)	Termination cross section		Contact- Ø
				AWG	mm ²	
	080 000 026 000 000	080 000 040 000 000	080 000 041 000 000			
	Crimp dies					
				24/28	0,08/0,25	0,76
						1,02
						1,5
		080 000 040 000 000	080 000 041 000 000	26/28		0,7
		080 000 040 000 000	080 000 041 000 000	22/24		0,7
				22	0,38	0,76
				20/22	0,38/0,50	1,02
						1,5
						2,41
						3
				18	1	1,5
						2,41
						3
				16		1,5
				14	1,5	1,5
						2,41
						3
080 000 012 000 000				12		2,41
					2,5	2,41
						3
080 000 011 000 000					4	3
						5
080 000 011 000 000					6	4
	080 000 026 110 000				10	5

Crimp Tools and Contact Preparation

Crimping creates an easy, reliable, corrosion-free, and long-term connection between conductor and contact. It requires little skill and can be performed by non-experts.

Crimping causes cold-flow of the conductor and contact material creating a gas-tight connection between contact and conductor. A stiffening of the conductor at the connection, as it is possible with soldering, can not occur. Crimping can be performed on very small or very large conductor cross sections.

For smaller cross sections (0.5 - 2.5 mm²) an industry-standard 8-point crimp tool is used. Larger cross sections require a hexagonal crimp press. For very large cross section the crimp procedure has to be done in several steps to assure good cold-flow of the conductor material and to avoid a brittle connection.



8-Crimp Tool. Adjustable for cross section from 0.08 - 0.5 mm² (AWG28 - AWG20)
Table for adjustment and Contact holder = positioner - see page 46/47

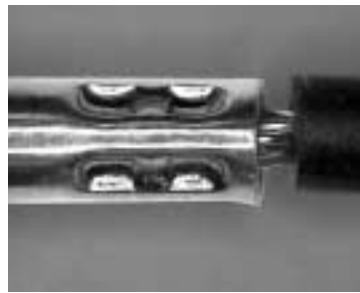

Order Number: 080 000 037 000 000



8-Crimp Tool. Adjustable for cross section from 0.38 - 2.5 mm² (AWG22 - AWG12)
Table for adjustment and Contact holder = positioner - see page 46/47

Order Number: 080 000 038 000 000

Crimp Instruction (for above tools)

Correct crimp position will be attained by use of different Positioner.
By rotating the selector knob to selected number you will get the correct crimp connection.
The crimp tool has an internal ratchet which opens only after completing the crimp process.



8-Crimp Tool. Adjustable for cross section from 0.08 - 2.5 mm² (AWG28 - AWG12)
Gauge on request.

Table for adjustment and Contact holder = positioner - see page 46/47

The crimp tool has an internal ratchet which opens only after completing the crimp process.

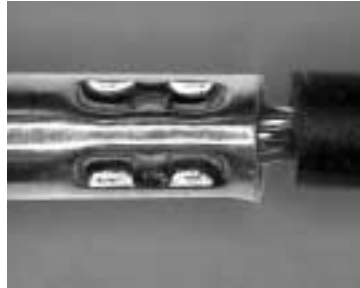

Order Number: 080 000 014 000 000



8-Crimp Tool with pneumatic activation.

Adjustable for cross section from 0.08 - 2.5 mm² (AWG28 - AWG12)

Gauge on request.

Table for adjustment and Contact holder = positioner - see page 36/37

Order Number: 080 000 032 000 000

Crimp Instruction (for above tools)

How to set the crimp tool according to the cable cross-section

1. Close crimp tool completely and keep it closed.
2. Adjust the tool so that the smaller gauge-pin just fits through the hole but not so the bigger one. In order to achieve that you have to adjust the tool with the adjustment bolt. After the tool is set properly you have to secure it with the fastening screw in order to avoid a misadjustment by accident.
3. Check the proper setting after a while by use of both gauge-pins.



Hexagonal Crimp Tool for AWG 12, 4.0-6.0 mm² cross sections, with locking system (ratchet).

For cross section AWG12: Order Number 080 000 012 000 000
For cross section 4,0 - 6,0 mm²: Order Number 080 000 011 000 000

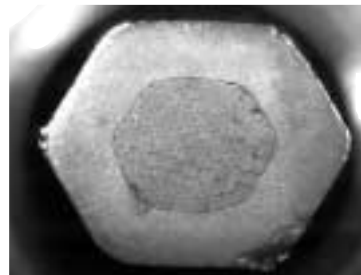

Hydraulic Crimp Tool for cross sections 10 mm² to with safety valve for automatic release when correct pressure is reached.

Order Number - Crimp tool: 080 000 026 000 000
Crimp die: 080 000 026 110 000

Crimp Instruction (for above tools)

How to set the crimp tool according to the cable cross-section

1. Before use insert the proper crimp jaws open the retainer claws by pressing the locking belt.
2. Now put the crimp jaws on the fixing pins, close the retainer claws and lock them.
3. Build up the hydraulic pressure by pumping the grip until you hear a "click".
4. The crimp process is finished now and you can open the tool with the set-back trigger and the crimp part will be released.



Hexagonal Crimp Tool for coax contacts, with locking system (ratchet).



Order Number: 080 000 039 000 000

Crimp tools for stamped contacts



Hand crimp tool for single contacts
Here Single Contacts are inserted into the tong manually and are crimped.

Order Number: 080 000 040 000 000



Hand crimp tool with spool
The hand crimping tool feeds the contact on a tape and the contacts are separated automatically during the crimping process. Contacts are moved forward by hand operation.



Order Number: 080 000 041 000 000



Stripper-Crimper for automatic crimping

To order by:

Fa. Schäfer

Werkzeug- und Sondermaschinen GmbH

Dr.-Alfred-Weckesser-Straße 6

D-76669 Bad Schönborn-La.

Phone: 0 72 53 / 94 21-0

Fax: 0 72 53 / 94 21-94

Internet: www.schaefer-werkzeugbau.com

eMail: info@schaefer-werkzeugbau.com

Adjustment of the Crimp Tongs 080.000.037.000.000 and 080.000.038.000.000
(see page 48)



1. Fasten the Positionier on the Crimp Tong



Please fasten the Positionier under consideration of the guiding into the tong



037: Therby push the positionier down and turn it right at the same time.
038: You don't have to do this with this tong.



037: To fix the positionier in this position, you have to use the attached safety pin.
038: Here you have to fix the positionier with some attached allen screw and the suitable spanner.

2. Adjust of the Crimp Tong for the cable cross section



Please turn the adjustment wheel onto the right position. If the adjustment is done, so please fix the wheel with the attached safety pin.

Now the tong is ready adjusted. You can start with the crimp process

Adjustment of the Crimp Tong 080.000.014.000.000

(see page 49)

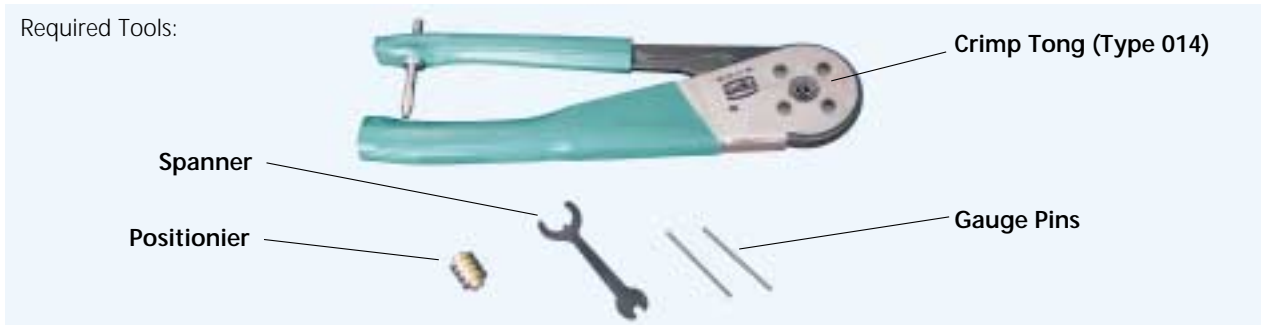

1. Fasten the Positionier on the Crimp Tong



Please insert the positionier into the tong.

Attention: The positionier is labeled with a "S" (=Socket) on the one, and with a "P" (=Pin) on the other side. So if your contact is a socket, so please insert the S-face into the tong. If your contact is a pin, so please insert the P-face into the tong.



Now you have to insure the positionier with a clamp. Fix the clamp with the screw driver.

2. Adjustment of the Crimp Tong for the cable cross section



At first you have to loose the securing nut of the setscrew. Therefore please use the attached spanner.

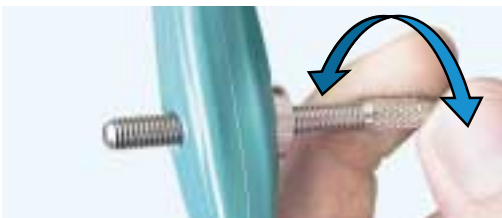

With turning on the setscrew you can adjust the cable cross section. Therefore you have to close the crimp tong completely.



With the gauge pins you have to prove the cable cross section. If the smaller gauge pin fit trough the hole in the crimp dies, and the bigger one not, the the tong is ready adjusted. Please insure the adjustment with the securing nut.

Now you can start with the crimp process.

Crimp Termination
According to DIN IEC 352

Pull-out forces diagram of a crimp termination
according to the wire cross-section
(Extract of DIN 352 – part 2)

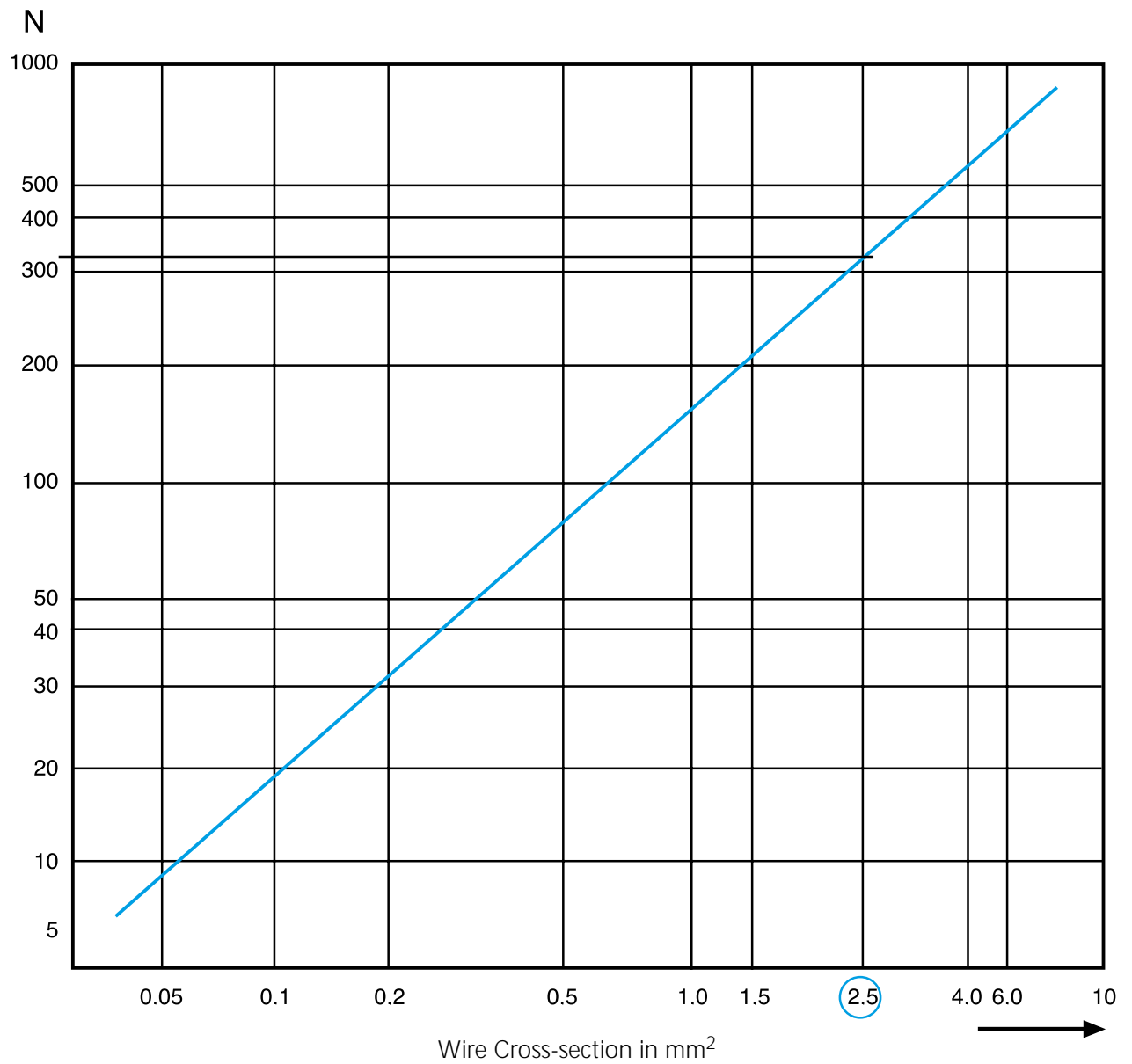

Example: For a 2.5 mm² wire a minimum pull-out force of appr. 320 N is required

Explanations of voltage information in compliance with VDE

Standards applied:

DIN EN 60664-1 (VDE 0110 – Part 1)
 DIN EN 61984 (VDE 0627)

General information: :

A connector cannot be chosen by taking into consideration only functionality, number of contacts and current or voltage characteristics. The consideration of the place where it will be used and the installation conditions that prevail there are essential. Depending on the installation conditions and local conditions, the connector can be used in different voltage and current ranges, according to the standardization.

All voltage information listed in this catalog refers to use of insulators in ODU MAC DIN solid frames or ODU MAC aluminum frames.

The most important influencing quantities and the electrical characteristics tuned to them are explained in more detail in the following. If you have further questions, we would happy to provide support.

The following texts and tables are excerpts from the specified standards. The originals, DIN EN 60664-1 from Nov. 2003 and DIN EN 61984 from Sep. 2002, remain authoritative for all technical information given.

Overvoltage category

Using the overvoltage category, the necessary rated surge voltage is defined according to Table 1 and the nominal voltage used. The particular overvoltage category for the device, depending on the installation location, is selected according to the criteria listed below.

- **Overvoltage category I:**
 Devices for connection to electric circuits in which measures have been taken to limit transient overvoltages to a suitable low level.
 For example: Connectors for the power supply of computer hardware that is permanently connected to a power pack with electronic overvoltage limiting.
- **Overvoltage category II:**
 VDevices that consume energy and that are supplied from the fixed wiring system.
 For example: Household appliances, portable tools and similar devices
- **Overvoltage category III:**
 Devices in fixed wiring systems and for those cases in which particular demands are placed on the reliability and availability of the devices.
 For example: Switches in fixed wiring systems and devices for industrial use with permanent connection to the fixed wiring system.
- **Overvoltage category IV:**
 Devices for use at the wiring system connecting point.
 For example: Electric meters and primary overvoltage protective devices

Nominal voltage of the electric power supply system according to IEC 60038, in V		Voltage line to neutral derived from nominal voltages a.c. or d.c. up to and including V	Rated impulse voltage V			
			Overvoltage category			
Three-phase-system	Single-phase-system with midpoint		I	II	III	IV
	120-240	50	330	500	800	1500
		100	500	800	1500	2500
		150	800	1500	2500	4000
230/400 277/480		300	1500	2500	4000	6000
400/690		600	2500	4000	6000	8000
1000		1000	4000	6000	8000	12000

Pollution degree:

Combined with moisture, any pollution that may arise can influence the insulating property on the surface of the connector. For defining the different rated values, a pollution degree must be selected for the device, according to the criteria listed below.

For a connector with a degree of protection of at least IP 54 (to IEC 60529), the insulating parts inside the encapsulation may be measured for a lower pollution degree according to the standard. This also applies to inserted connectors where the encapsulation is ensured by the connector housing and that are detached only for testing and maintenance purposes.

- **Pollution degree 1:**

There is either no pollution or only dry, non-conductive pollution; the pollution has no influence.
For example: Measuring instruments and hardware in computer systems

- **Pollution degree 2:**

Only non-conductive pollution occurs.

Transient conductivity caused by dewfall must be expected occasionally, however.

For example: Devices in laboratories and in living areas and sales and other commercial areas.

- **Pollution degree 3:**

Conductive pollution occurs or dry, non-conductive pollution that becomes conductive because of dewfall must be expected.

For example: Devices in industrial, commercial and agricultural operations, unheated storage areas and workshops.

- **Pollution degree 4:**

Continuous conductivity occurs, caused by conductive dust, rain or wetness.

For example: Devices in open-air plants and on construction machines

Operating voltage (VDE: rated voltage)

The level of a voltage that is specified by the manufacturer for a component, device or piece of equipment and to which the operating and performance parameters apply.

The rated voltage depends on the connector's insulating material group and the respective creepage distances between the separate contacts, according to the specified pollution degree.

By using empty modules and by differing the positioning of the contacts in the insulators, it is possible to influence the rated voltage considerably.

(Devices are permitted to have more than one value for the rated voltage or to have a range of rated voltages).

Nominal voltage:

A suitable rounded voltage level, which is specified for a device by the manufacturer for labeling or identification.

In these explanations, the term nominal voltage is used for the value of the output voltage specified by the power company or the manufacturer of the voltage source for classification of the overvoltage category.

Rated impulse voltage

Value of the impulse test voltage that is specified by the manufacturer for a device or a part thereof and that indicates the defined staying power of its accompanying insulation against transient (short-term, lasting a few milliseconds) overvoltages. The impulse test voltage here is the highest level of the impulse voltage of a defined shape and polarity that is not permitted to lead to any insulation disruptive discharge under defined conditions.

The rated impulse voltage depends on the clearance distance between the separate contacts, according to the specified pollution degree.

By using empty modules and by differing the positioning of the contacts in the insulators, it is possible to influence the rated impulse voltage considerably.

Impulse test voltage/power-frequency test voltage

Highest value of the impulse voltage of a defined shape and polarity that is not permitted to lead to any insulation disruptive discharge or sparkover under defined conditions.

Clearance distance:

Shortest distance between two conductive parts, through the air.

Creepage distance:

Shortest distance between two conductive parts, along the surface of an insulating material. (The creepage distance is influenced by the pollution degree used).

Test Voltage:

The connector's electric strength is tested to the standard according to the specified rated impulse voltage by applying the test voltage (impulse test voltage or power-frequency test voltage according to Table 2) over a defined time period.

Table 2

Rated impulse voltage kV	Test voltages		
	Impulse test voltage kV (1,2/50 μ s)		Power frequency test voltage kV (50/60 Hz)
	up to 2000 m	Sea level	
0,5	0,5	0,55	0,37
0,8	0,8	0,91	0,50
1,5	1,5	1,75	0,84
2,5	2,5	2,95	1,39
4	4	4,8	2,21
6	6	7,3	3,31
8	8	9,8	4,26
12	12	14,8	6,60

A interpolation of the rated impulse voltage is acceptable, if the testing laboratory ist between sea level and 2000 m.

Explanations of voltage information in compliance with MIL:

Standards applied:

SAE AS 13441-method 3001.1
 MIL-Std 1344-method 3001
 IEC 60512-2, Test 4a

General information:

The values according to SAE AS 13441-method 3001.1 correspond to those of MIL-Std 1344- method 3001. The specified values were determined in accordance with IEC 60512-2, Test 4a.

Each insert was tested when inserted, whereby the test voltage was applied to the male insert.

All tests were conducted at normal room climate and are valid to an altitude of 2000 meters.

If there are deviations, the reduction factors according to the relevant standards should be taken into consideration.

Test Voltage:

The test voltage is defined as 75% of the disruptive discharge voltage established according to the standard.

$$\rightarrow \text{Test Voltage} = \text{disruptive discharge voltage} \times 0,75$$

Operating voltage:

According to the standard, the operating voltage is defined as 1/3 of the established test voltage.

$$\rightarrow \text{Operating voltage} = \text{disruptive discharge voltage} \times 0,75 \times 0.33$$

Please note:

For some applications, the safety requirements for electric devices are very strict with regard to the operating voltage. In these cases, the operating voltage is correspondingly defined according to the clearance and creepage distances between exposed parts. When making a selection for these connectors, please contact us and tell us the safety standard with which the product must comply.

Testsystem for Airbus



Before being built into an aeroplane, every single electrical component of an aeroplane must be thoroughly tested.

This company develops and builds test and simulation systems for the aviation industrie.

ODU MAC handles the signal distribution in the test simulation system (for control computers) that was developed for the the new Airbus A340/600. Around 3,500 signals pass through the ODU connectors. Such a system has 30 ODU MAC connectors



!SHORTINFO!

- ODU MAC in DIN housing
- Size 2 and 4
- Spindle locking
- Signal and Power contacts

ODU MAC Assembly Robots



The fast-change system, allows fast reconfiguration of the basic system with product neutral components and interface with product-specific workstation. This innovative approach results in about 1/3 of the cost savings and significant increased flexibility in fabrication. The ODU MAC in the aluminium frame is used as an electropneumatic I/O interface. The ODU MAC in DIN housing is installed on the handling and supply modules on the upper assembly level. It is worth mentioning that the ODU MAC is used here to its full capability with fiberoptic contacts, compressed-air couplings, power, signal and coax contacts.

!SHORTINFO!

- ODU MAC in DIN housing
- Locking Latch
- Pneumatic-, Signal- and Powercontacts
- ODU MAC in Alu frame
- Pneumatic-, Signal- and fiber optic contacts

OP of the future

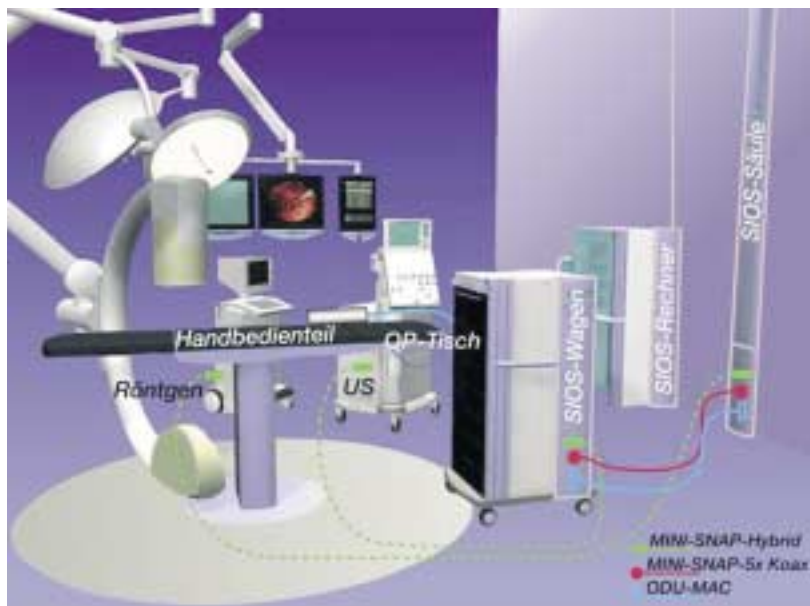

For the first time, the surgical team using this system can control all functions which are necessary in the working environment within the sterile area.

All important image informations (e.g. X-Ray) can be displayed on the monitor.

This System will allow to connect operating rooms in a network – worldwide.

!SHORTINFO!

- ODU MAC in DIN housing - white
- Spindle locking
- Signal- and coax contacts

ODU MAC in Aluminium Frame,
 mixed contact configuration in „Quick-Change Head Technology“
 for extremely high mating cycles - mating part exchangeable

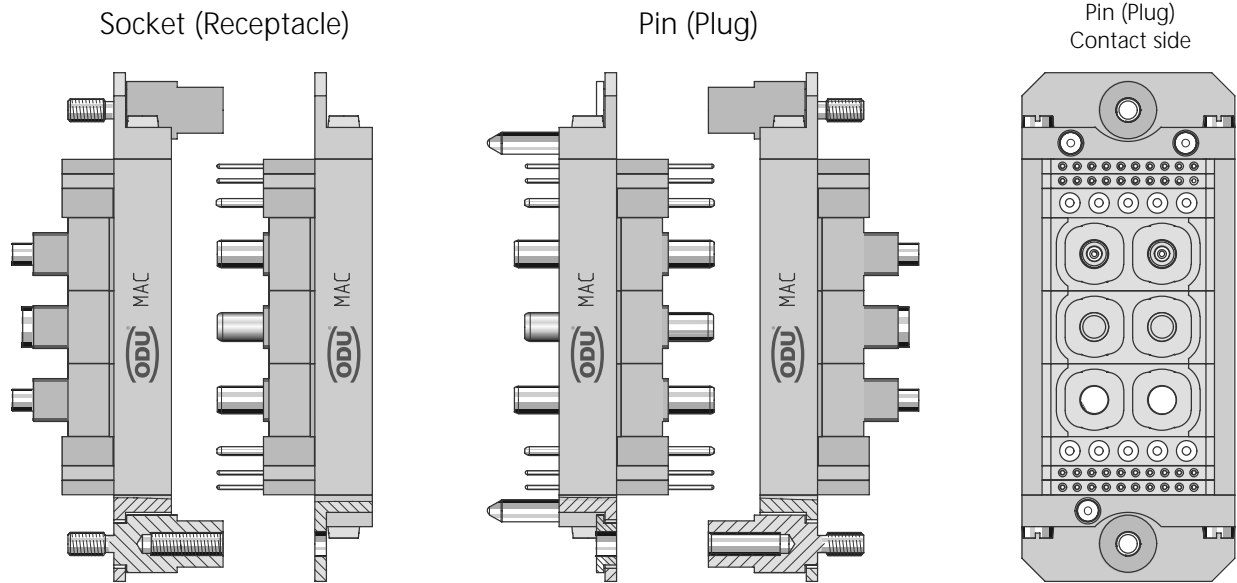

in mating condition

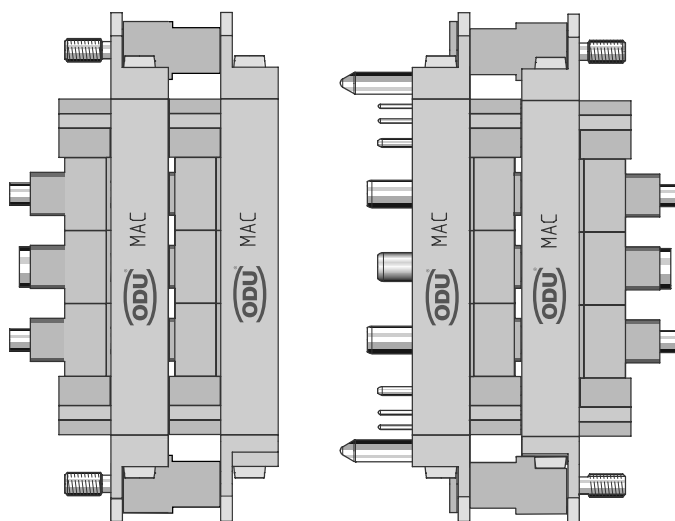

Connection during the testing of mass-produced electronic articles

Car radios, video recorders, mobile telephones, fuel injection pumps, motor controllers, printers, printed circuit boards, video screens, frequency converters, microwave ovens, ABS systems, automobile motors, electric scales:

all of these products are produced in large-scale manufacturing and must be tested.

This requires that the products (test pieces) be connected and attached to a test computer.

The test requires:

1. connection to the product and,
2. in most cases, an interface (a connector) between the test piece and the computer.

ODU has developed special products that are being used worldwide for both tasks.

1. Connection to the product

Let's take as an example a through-hole plated printed circuit board: it has a huge number of soldering points, i.e., contact points. It can be effectively connected using spring-loaded pins (pogo pins). The pins are usually attached to so-called needle beds, which naturally appear different for different printed circuit board geometries (layouts).

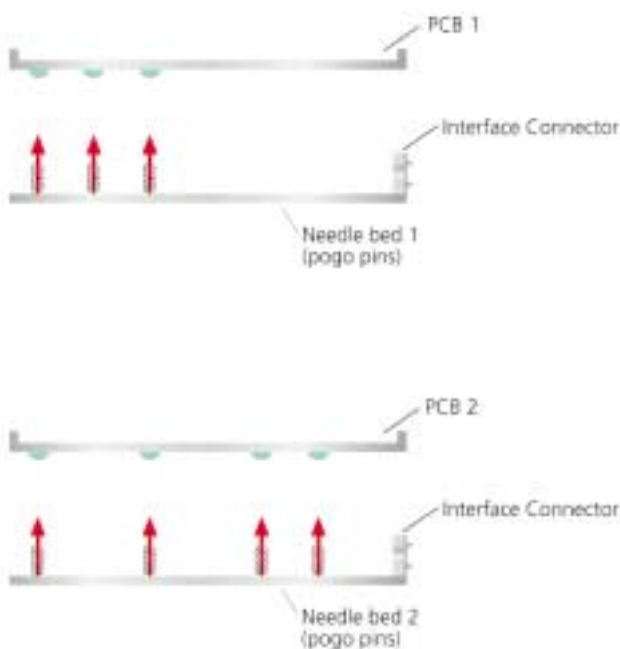

Connection of printed circuit boards with spring-loaded pins on needle bed.

Figure 1

Let's take as an additional example a product from the automobile electronics field, for example, a motor controller. These products usually have flat pins as contacts (for example, 0.8 x 2.8 mm). The connection could be done using appropriate mating connectors (sockets), as used in series production. But the problem here is that the socket contacts of the mating connectors for the series usually have only a very limited lifetime.

After 500 or at most 1000 insertion/withdrawal cycles, the failure probability rises sharply. A remedy for this is to use special test adaptors with special springwire flat contacts, such as ODU has developed. These contacts tolerate several hundred thousand insertion/withdrawal cycles with a very high degree of reliability.



ODU springwire socket for the connection of flat contacts (for example, 0.8 x 2.8 mm). The socket permit many hundred thousand insertion/withdrawal cycles.

Figure 2

Likewise, ODU has developed special springwire contacts for very high insertion/withdrawal cycles for square pins (for example, 0.64 x 0.64) and for round pins (for Ø from 0.7 to over 10 mm).



ODU springwire sockets for the connection of round contacts (from Ø= 0.7 to over 10 mm) and square contacts (for example, 0.64 x 0.64). Under ideal conditions, over 1 million insertion/withdrawal cycles are possible.

Figure 3

2. The interface

Basically, it is possible to connect the product and insert the values directly into the test computer. However it can very quickly be seen that it's expedient to provide an interface (a connector) between the test piece and the computer. This can be explained by an example.

Example: Testing car radios – an absolutely typical case!

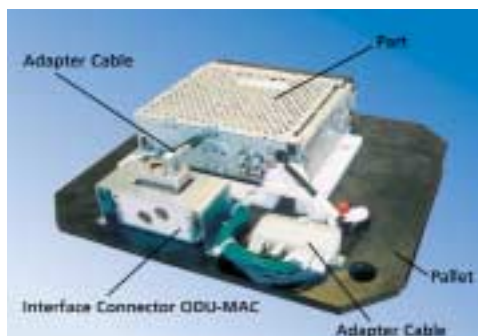

Carrier rack for test line with test piece (car radio) and ODU-MAC (socket part)

Figure 4

In Figure 4 one sees a carrier rack with an interface connector (ODU-MAC) permanently mounted on it, a car radio and 2 adaptor cables, which produce the connection from the car radio to the ODU-MAC. The adaptor cables are permanently connected to the ODU-MAC while on the side of the car radio they are freshly inserted for every test piece. The interface connector (ODU-MAC) is then docked within the framework of the test step in the test line so that the signals can be transmitted over the mating connector to the computer side and can then be processed in the computer.

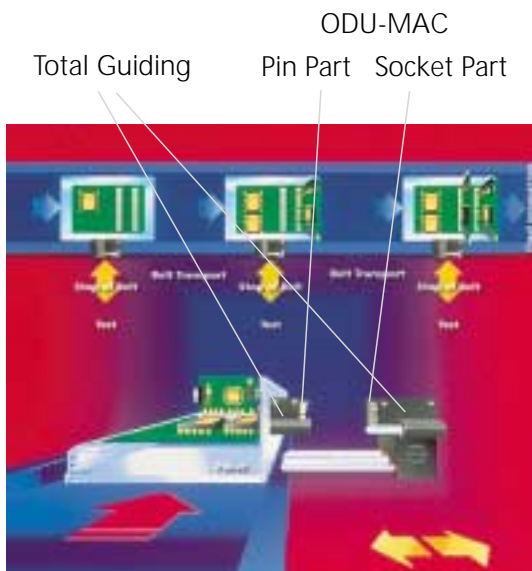

Test line with racks for multiple testing.
Docking system with total guiding and ODU-MAC with guiding for the connector.

Figure 5

In this case the adapter connectors are worked with every tested radio. Especially high demands are placed on the ODU-MAC: the connector on the computer side is worked at least 10,000 times for 10,000 radios per day, and proportionately more in the case of multiple tests. This means at least approximately 3 million insertion/withdrawal cycles a year! In addition, in this case the ODU-MAC must be equipped with power contacts, signal contacts and high frequency (HF) contacts with 75 Ω characteristic impedance.

Here one can – rightfully – ask the question: why provide an expensive interface connector when the adaptor cable connector still has to be plugged in – usually manually – anyway?

There are different, mutually independent reasons for this:

- Program change

Multiple test on the same test piece (Figure 5)

Without interface connectors, the adaptor cables would have to be repeatedly plugged by hand, which would mean multiple time required and also that the adaptor connector would wear out earlier.

The high number of insertion/withdrawal cycles is shifted to the ODU-MAC, which is suitable for this.

- Better utilization of the expensive test computers

The attachment of the adaptor cable is often truly time-consuming since several different connectors must be multiply plugged – mostly by hand. So it is expedient to plug the adaptor cable to the racks in a decentralized manner at a great distance from the test computer and then to run the racks quickly through the test line.

- Buffer stock

This reason is closely related to the one above. With decentralized preparation, the adaptor cables can be plugged in the 2nd and 3rd shift, for example, while the test line and test computer run only during the main shift under the presence of the permanent staff.

In the following, the use of interface connectors in the case of program changes and for additional examples is explained.

Program change

Example: Testing printed circuit boards

Let's assume that a factory produces the different printed circuit boards Nr. 1, 2 and 3. Then it needs the needle beds Nr. 1, 2 and 3 as adapters for the connecting the printed circuit boards. In order to connect needle bed Nr. 1 with the test computer, the interface Nr. 1 is provided, for needle bed Nr. 2 the interface Nr. 2, etc.

It's expedient to execute the mating connector on the computer side in such a way that it covers interfaces 1, 2 and 3.

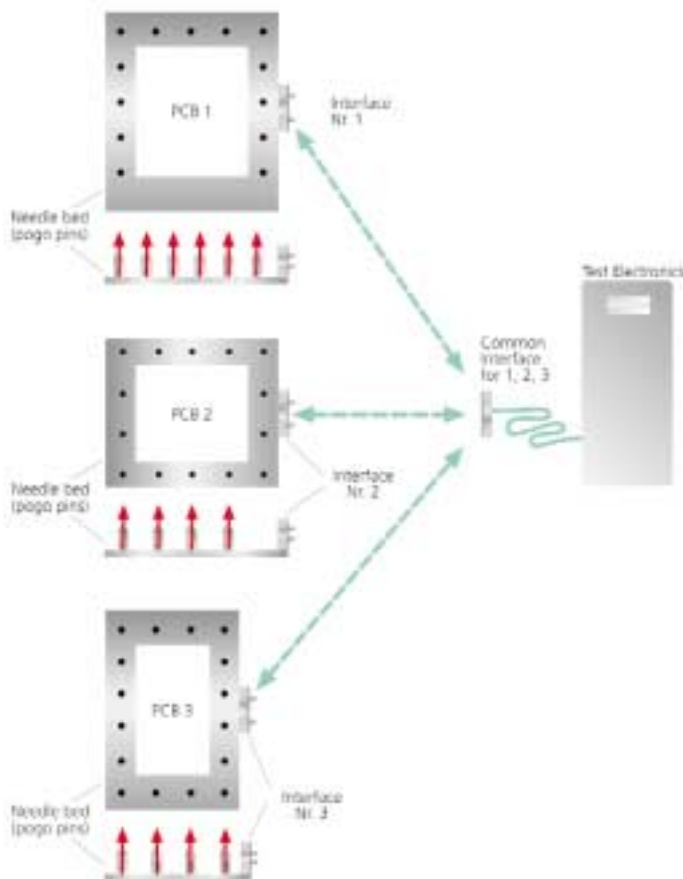

Connection of different printed circuit boards with different needle beds and uniform interface on test computer for program change.

Abbildung 6

In practice, it happens that a special test machine is used, for example, through which the printed circuit boards run on a conveyor.

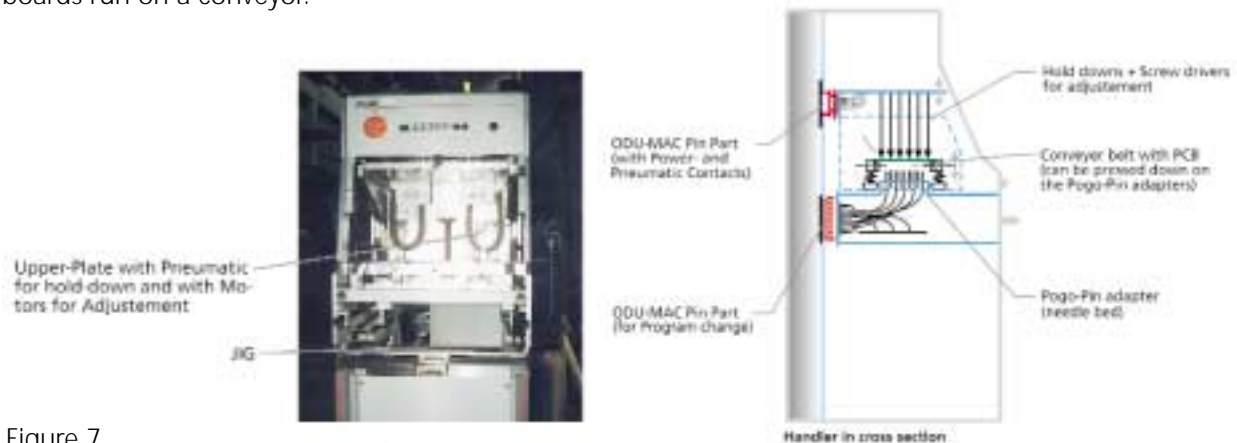

Figure 7

Testing of printed circuit boards for ICCT and function test

The printed circuit boards are thereby pressed against the needle bed from above during a short conveyor stop and the signals run over the interface connector to the computer. If the production program is changed every week, for example, then the interface connector is worked at least once every week.

The demands on the ODU-MAC's insertion/withdrawal cycles are not very great here, because the insertion/withdrawal cycles accumulate on the spring-loaded pins on the needle bed. On the other hand, the ODU-MAC, under certain circumstances, must have a very high number of poles (certainly several hundred).

As the interface connector for such applications, the ODU-MAC, developed by ODU, has gained acceptance all around the world.



ODU-MAC – the modularly attachable connector system which can be strung together.

Figure 8

Example: Testing mobile telephones

In principle, everything is the same as for the testing of auto radios, which was outlined above. The differences are: the connection of the mobile telephones doesn't take place over adaptor cables but instead over their outer connectors in connection beds and 4 telephones are always tested simultaneously.



Docking station for testing 4 mobile telephones (demo model). The 4 coaxial contacts for 50 Ω (4 GHz), the 4 x 10 signal contacts and the 4 x 2 power contacts can be seen.

Abbildung 9

Example: Testing electric motors in a testing stand

Here the racks don't run along a conveyor, but instead are mounted in a test stand and are pushed back and forth in the test stand. As is the case for the mobile telephones, the adaptor cables are replaced by direct connection on the rack.

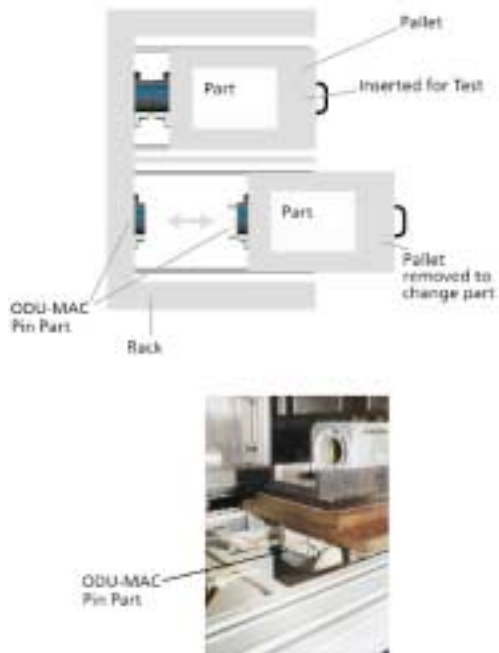

High voltage testing (3 kV) of electric motors. The adapter cable is replaced by direct connection to the rack.

Figure 10

Example: Climate and temperature test

Figure 11 shows transport wagon with 2 x 9 frames for the seating of 18 racks, each with a test piece. Each rack has an ODU-MAC; the 18 ODU-MAC mating connectors can be seen in the transport wagon. The 18 racks with the test pieces are plugged in the wagon by hand and the wagon is driven in to the climatic chamber.

The signal and power contacts are joined together and guided out of the climatic chamber.

They are joined together in one ODU-MAC connector in double DIN housing.

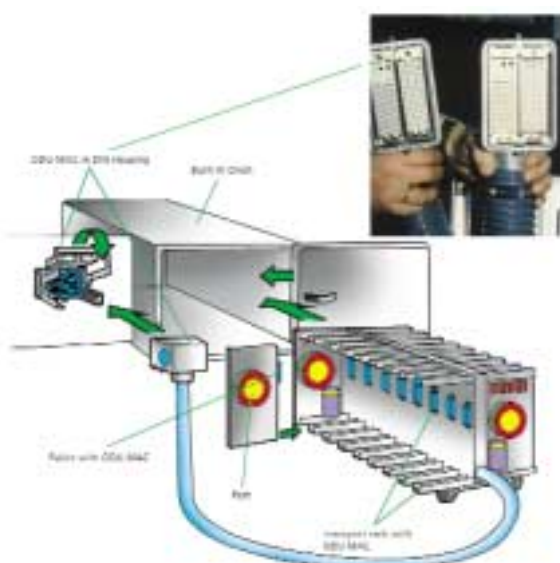

Climatic test of frequency converters.

Abbildung 11

Example: Testing injection vents

The opening and closing of injection vents is today increasingly controlled electrically using magnetic vents. These magnetic vents have flat contacts. Here the ODU springwire flat socket has proven itself for the adapting, and the ODU-MAC has also proven itself as an interface connector. Otherwise the conditions are as described above for the car radio.

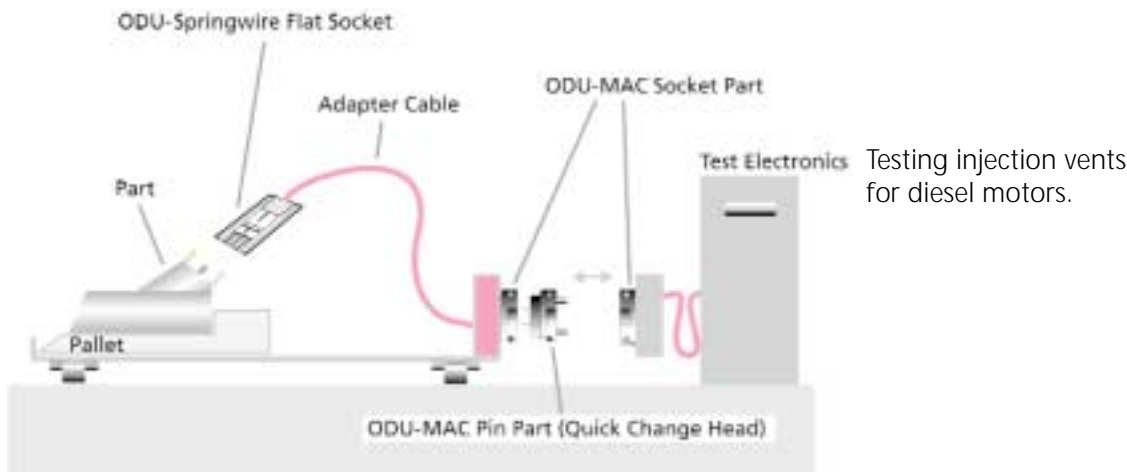

Figure 12

Remarks about the interface connector ODU-MAC

In Figure 8, the modularly-built connector ODU-MAC can be recognized: a pin part and a socket part, each made up of an aluminium frame and the module, i.e., the insulating body with the contacts. The aluminium frame is made of an end piece, 2 rails and an end piece. The total length of the assembly can be freely selected up to approximately 25 cm: power contacts, signal contacts, HF contacts up to 4 GHz, fiber optic contacts, pneumatic elements. All together, over 50 different modules are available. The contacts are supplied for crimp, solder and print connection.

All contacts are assembled according to the ODU springwire principle and allow many hundred thousand or even a million insertion/withdrawal cycles. In addition, they offer constant contact resistance – which is very important in test situations – and an extremely high degree of contact reliability.

For docking tasks, ODU-MAC is set into aluminium frames as described above. In addition, ODU-MAC is offered in DIN housing for manual connection with locking system.

Remarks about the installation of interface connectors and docking systems

Special attention should be given to the guiding system. The guide pins and sockets of the ODU-MAC serve **exclusively to guide the connector!** The guiding system when docking (between the docking system and the rack) must take place separately!

The standard version of the ODU-MAC is intended for a floating mounting of ± 0.6 mm. This means that the docking system guide must be selected so that the tolerance lies under ± 0.6 mm. One possible solution for a docking system with a built-in ODU-MAC can be seen in Figure 13.

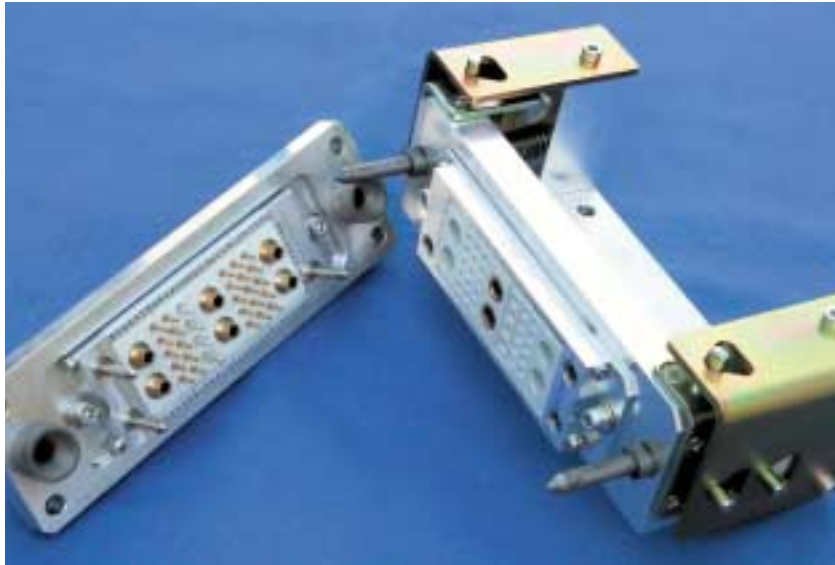

Docking system with total guiding and ODU-MAC.

Figure 13

Under some circumstance, several hundred racks are in circulation in test lines. These are usually docked to only a few docking stations in order to produce the connection to the test computer. If 100 racks are in circulation and if every rack is docked to 2 test stations, the result is that the ODU-MAC on the computer side carries out 50 times as many insertion/withdrawal cycles as the ODU-MAC on the racks. It is recommended to provide the pin parts on the racks and the socket parts on the docking station, because the socket parts permit approximately 10 times as many insertion/withdrawal cycles as the pin parts. Additionally, they are more expensive.

As a rule, the working of docking systems in test lines is done using pneumatic cylinders. Although the ODU springwire contacts have low insertion and withdrawal forces, large forces can still result in the case of connectors with a large number of poles; under certain circumstances the forces are greater than 100 N. The theoretically required insertion force according to the catalogue should be raised by a safety factor of three for the layout of the device doing the working.

Some remarks about the profitability. References.

Test equipment is expensive. The costs must be seen in connection with the use. **In no case should costs be saved on the connection!**

In addition to the costs for the test computers, the test equipment /line and the docking system must be taken into consideration. In addition to the costs for the adaptation, costs for the interface connector ODU-MAC arise as well as, under some circumstances, considerable costs for their mass production.

On the other hand it needs to be taken into consideration that not only insufficiently tested products can lead to failure and dissatisfaction. In addition, bad test equipment leads time and time again to error messages, especially due to bad connection.

Under some circumstances, flawless products are rejected. This can lead to entire factories being brought to a standstill.

Some of the customers who have chosen the adaptor contact from ODU and the ODU-MAC are: Alcatel, Bosch, Daimler-Chrysler, Ericsson, Matsushita, Mitsubishi, Nokia, Oki, Philips, Samsung, Siemens, Sony, Wabco.

Approximately 100 million mobile telephones alone are currently being tested with ODU-MAC every year!

In addition to testing situations, ODU-MAC is being used in machine construction (pick and place machines, automatic assembly machines) and in medical technology, among other applications.

Documentation is available in German, English, French, Japanese and Korean.



ODU's headquarters and factory are located in Mühldorf, at the river Inn, approximately 50 miles east of Munich, at the foothills of the Bavarian Alps.



Bild der Stadt Mühldorf am Inn

Mühldorf, an idyllic small town with its typical Inn-Salzach architecture.

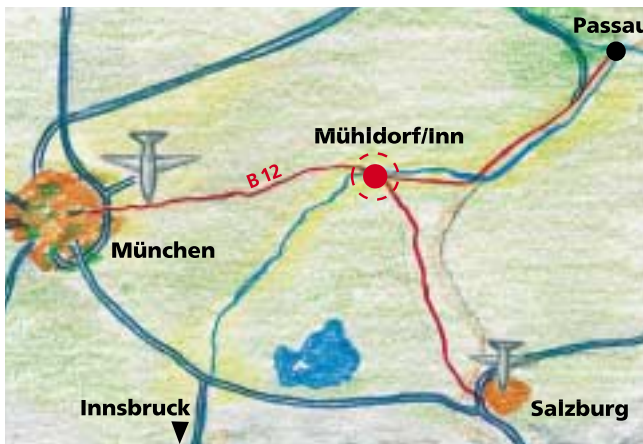

Steckverbindingssysteme

ODU Steckverbindingssysteme GmbH & Co. KG
Otto Dunkel GmbH

Pregelstraße 11 · D-84453 Mühldorf/Inn
Phone +49/86 31/61 56-0
Fax +49/86 31/61 56 49
Internet: <http://www.odu.de>
E-Mail: zentral@odu.de

ODU France
Téléphone: 01.39.35.46.90
Télécopie: 01.39.35.46.91
E-Mail:
jean-nicolas.vikelas@odu.fr

ODU USA Inc.
Tel. 805.484.0540
Fax 805.484.7458
E-Mail:
raif.eberlein@odu-usa.com
<http://www.odu-usa.com>

ODU UK Ltd.
Tel. 01509 266 433
Fax 01509 266 777
E-Mail:
sales@odu-uk.co.uk

ODU (Shanghai) Int. Trading Co. Ltd
Tel. +86/21-5834 78 28
Fax +86/21-5834 44 39
E-Mail:
oduchina@odu.com.cn
<http://www.odu-china.com>

ODU Scandinavia AB
Tel. +46/176-1 82 61
Fax +46/176-1 82 62
E-Mail:
peter.biloch@odu.se

ODU (Shanghai) Connectors Manufacturing Co. Ltd
Tel. +86/21-5834 78 28
Fax +86/21-5834 44 39
E-Mail:
markus.bernhuber@odu.com.cn
<http://www.odu-china.com>