



ODU MINI-SNAP

Miniature Cylindrical Connectors
with
Push-Pull-Locking
Series F



The latest version of this catalogue
is posted on our websites:
www.odu.de
www.odu-usa.com

More Push-Pull series see page 87

UL-File E110586 00 RT03566: see page 81
MIL-Specification: see page 82

All data and specifications subject
to change without notice.
All dimensions in mm.
All pictures are illustrations.

ODU MINI-SNAP Product Description	5
Applications	7
Important Issues At A Glance	8
Compatibility	9
Turned contact	10
ODU MINI-SNAP Series F	11
-The FP Locking Concept	12
-Sizes	14
-Part Number Key (see also cover)	15
-Housings	16
-Details for the Part Number Key	25
-Coding	26
-Housing Materials/Surfaces	26
-Insulation Body Material	27
-Inserts Series F	28
-Size 0	28
-Size 1	29
-Size 1,5	30
-Size 2	31
-Size 3	32
-Contact Type / Contact Surface-Contact Diameter	33
-Contact Termination Cross Section	34
-Collet System	36
-Right-Angled Print Contacts in the Receptacle	37
-Cable Bend Relief	38
-Drilling Patterns for PCB-contacts	39
Variations and Special Designs of the ODU MINI-SNAP	41
Accessories	45
Tools	55
Crimping Tools / Assembly Tools	56
Assembly Tools for Crimp Contacts (037 and 038)	57
Assembly Tools for Crimp Contacts (014)	58
Instruction Crimp Tool	59
Crimping Instruction	61
Spanner Wrench	62
Nutdriver for Slotted Mounting Nut	62
Assembly Instructions and Packing Information	63
Assembly Instructions	64
Cable Preparation	67
Torque	67
Packing Information	68

See next page



Technical Information	69
International Protection (IP) Classes (DIN EN 60 529)	70
Watertightness of the ODU MINI-SNAP	71
Insulation Groups / Nominal Voltage / Test Voltage	72
Nominal Voltage acc. to SAE AS 13441-method 3001.1	73
Current Load – Contacts	74
Termination Styles	75
Conversion Table AWG to Metric	76
Housing Materials / Surfaces	77
Electromagnetic Compatibility (EMC).	78
ODU MINI-SNAP in Signal Bus Applications	79
Autoclaving of ODU MINI-SNAP	80
Quality Management.	81
Tests	82
Technical Terms & Definitions.	83
Inquiry Form (Fax)	91

Product Description

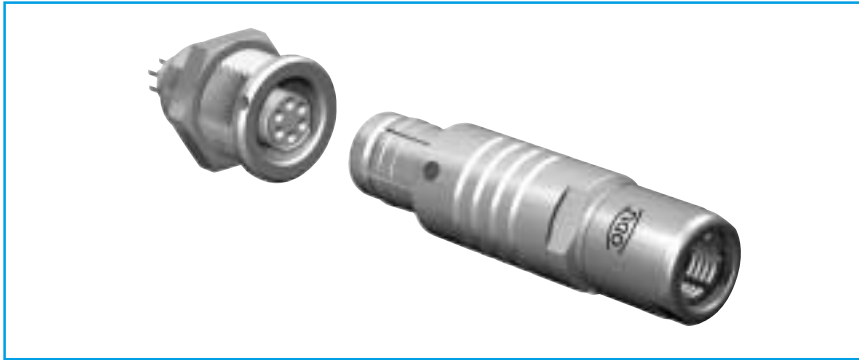

The ODU MINI-SNAP family of Miniature Cylindrical Connectors features Push-Pull-Locking

Cylindrical Connectors are generally available with several locking mechanisms.

The most frequently used are:

- Threaded-Locking Sleeve
- Bayonet-Locking
- Push-Pull-Locking

Push-Pull-Connectors have a very simple locking mechanism:

- As the plug is pushed into the receptacle, locking fingers on the plug snap into the receptacle creating a reliable connection between plug and receptacle.
- Pulling on the cable or the rear of plug causes the locking fingers to grab harder and a separation of plug and receptacle is almost impossible. Pulling on the outer plug housing causes the locking fingers to retract and the plug and receptacle separate easily.

The Advantages of Push-Pull-Connectors:

- Quick and easy mating and demating
- Quick and easy separating
- Easy blind mating in difficult-to-reach places
- Less panel space required
- Definite and secure locking condition
- Less mating required
- Robotic mating and demating possible
- Easy cleaning of housing possible

Important Applications for Push-Pull Connectors:

- Medical Electronics
- Test and Laboratory
- Measurement Instrumentation
- Data and Telecom Systems
- Audio and Video Applications
- Military and Aerospace
- Industrial Controls

Applications



Medical



Consumer electronics

Test and Measurement



Telecommunication

Industrial and Automation

Important Issues At A Glance:

- The series is certified acc. **UL** and VDE.
- **Connector with metal shells available in 5 sizes**
 Outside diameter between 9,4 mm and 18 mm
 Number of contact positions: 2 to 27 position, mixed insert arrangements
- **Plugs and inline receptacles** are offered with solder and crimp termination.
Receptacles are available for solder, crimp, and PCB termination.
- **Applications and Contact Material**

	Insulation PBT	Body Material PEEK	Contact Material Ms
General Application requirements ¹⁾ (-40 °C +120 °C)	●	●	●
Connectors which are autoclavable (+134 °C, see page 80)		●	●

- **Termination Style**
 - Crimp Termination ● ● *
 - Solder Termination ● ●
 - Printed Circuit Board
 (PCB) Termination ● ●

- **Environmental Protection Classification**
 IP 50 and IP 68 are available

* = Crimp-Clip Contacts with 0,7 mm diameter are available.

➔ What we don't have yet, we can build for you!

Compatibility

ODU MINI-SNAP compatibility with our connectors is defined as:

➔ Mounting and mating compatible

What does that mean for ODU®?

Most of our connectors are mounting and mating compatible with current products offered by W.W.Fischer™.

We can only provide a guarantee against reference parts.

Mating compatible implies that connectors from ODU® and W.W.Fischer™ can be mated and will function electrically and mechanically. This is especially important if the user switches from one supplier to another during ongoing production.

Mounting compatible means that the mechanical mounting parameters from ODU® and W.W.Fischer™ are identical. The connectors can be mounted into the same panel cutout or into the same PCB layout.

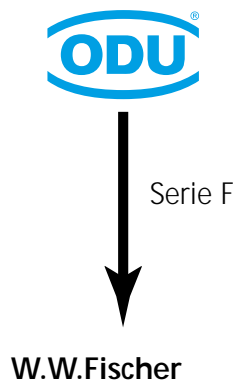

Most of the ODU MINI-SNAP connectors can be mated with products made by W.W.Fischer™.

➔ **There's no licence contract or cooperation with W.W.Fischer™**

ODU series F can be mated to different series of **W.W.Fischer™**

The ODU Series F

	Locking Principle	IP
Series F	FP with Halfshells	IP 50 and IP 68

Turned contact

Turned contacts are available from the metal version ODU MINI-SNAP in the diameters 0.5 to 1,3 mm.

The contacts are available with following terminations:

- Solder
- Crimp
- Print

Standard Pin Contacts

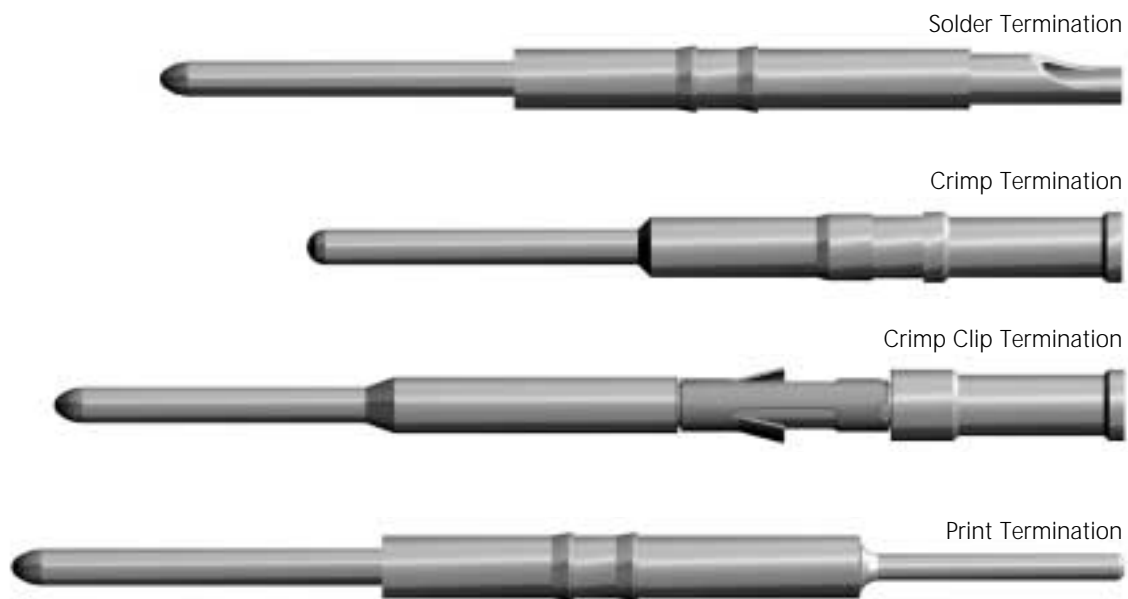

Mating cycles:	> 5000
Material:	Brass
Treatment processing:	At least. 1.25 µm Ni; at least. 0.75 µm Au

For information regarding diameter, termination style and current load please see the Contact Configuration section.

ODU MINI-SNAP



Series F - IP 50 and IP 68
FP-Locking Concept
Keying with Halfshells

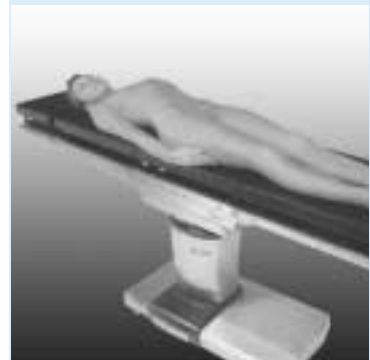

The Push-Pull Locking Principle: FP

with Halfshells

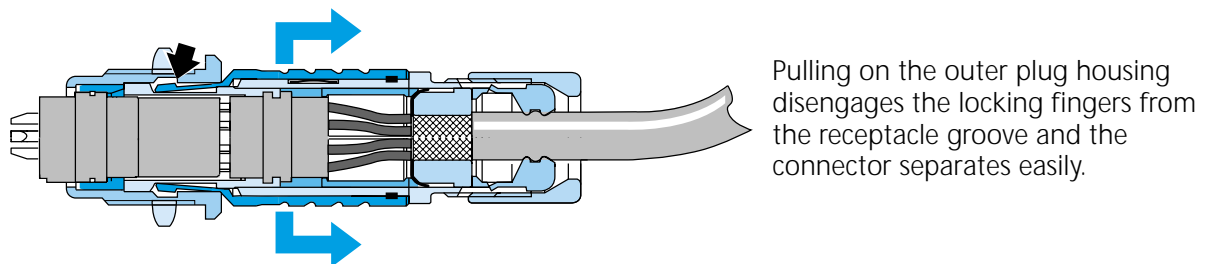
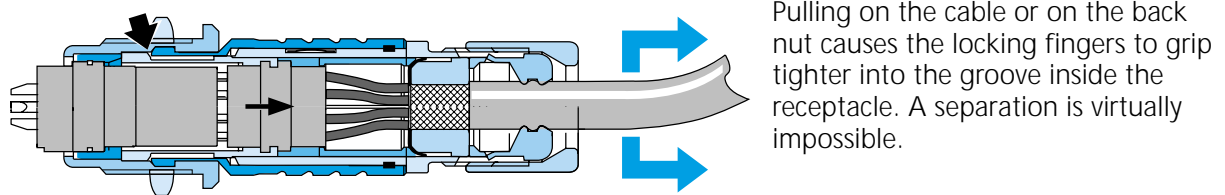
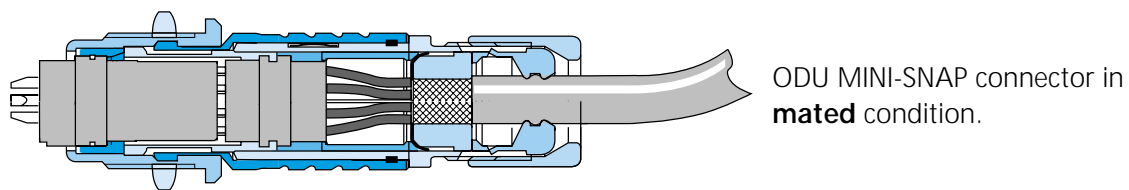
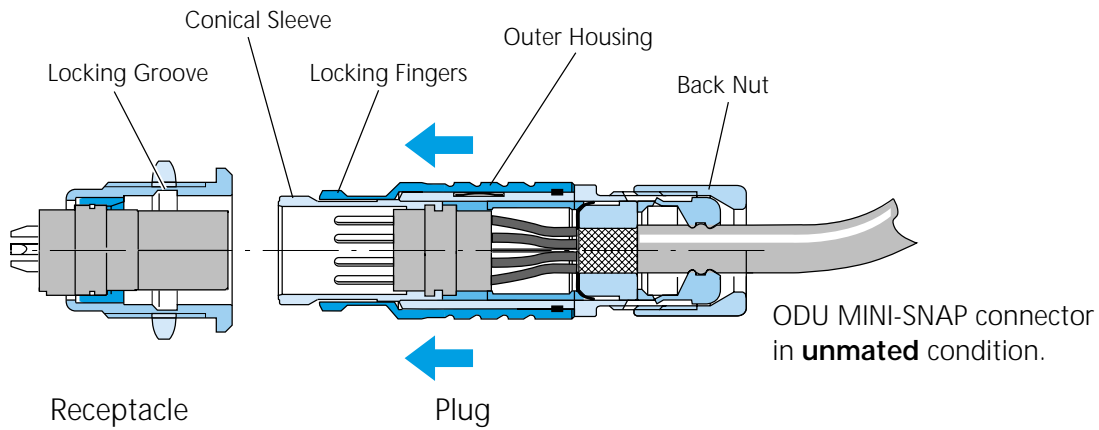

ODU MINI-SNAP

with FP-Locking Scheme in Cross Section

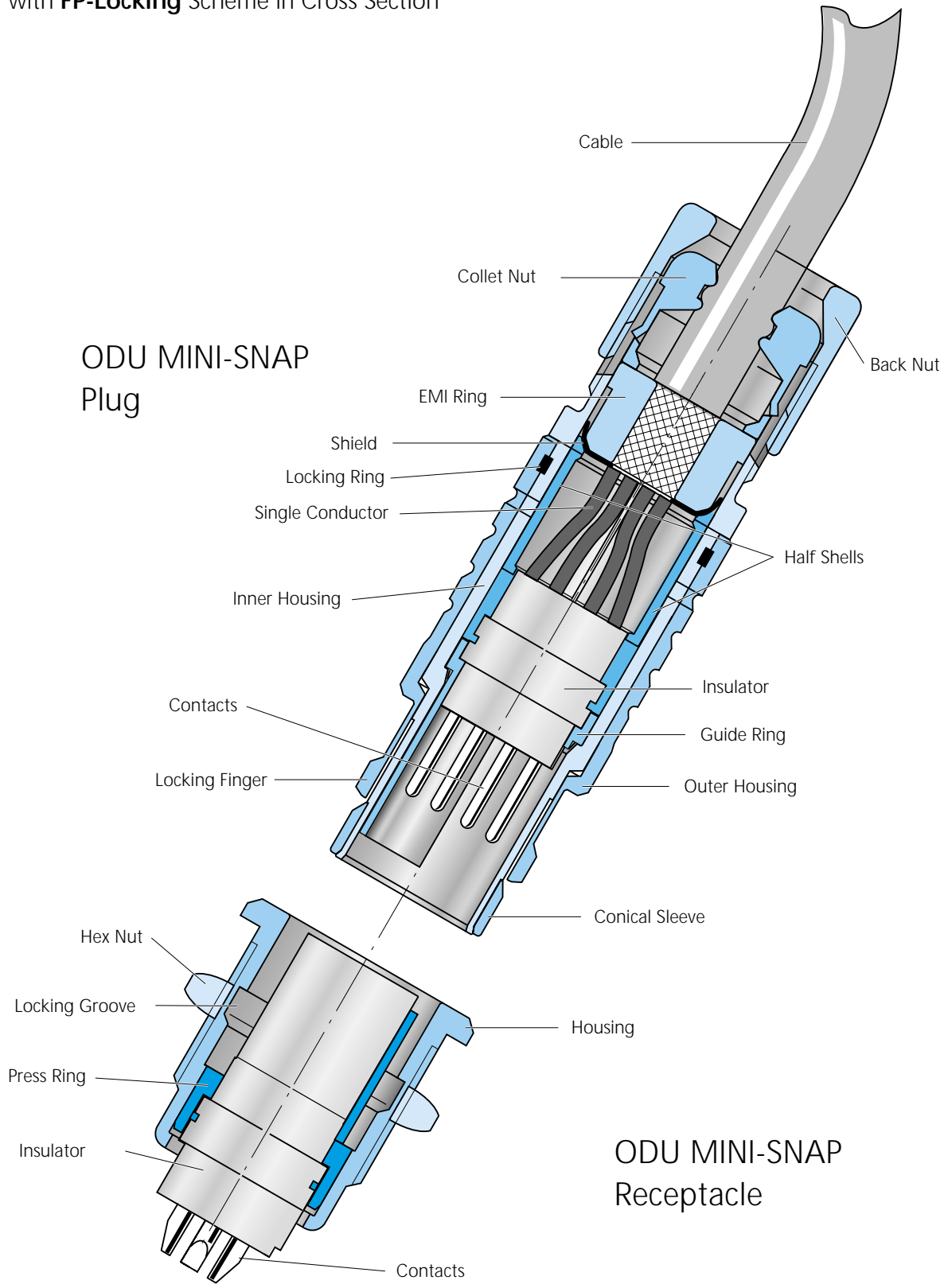

Available Housing Sizes

(Scale 1 : 1)

OD = Outside Diameter (Plug)

S = Size

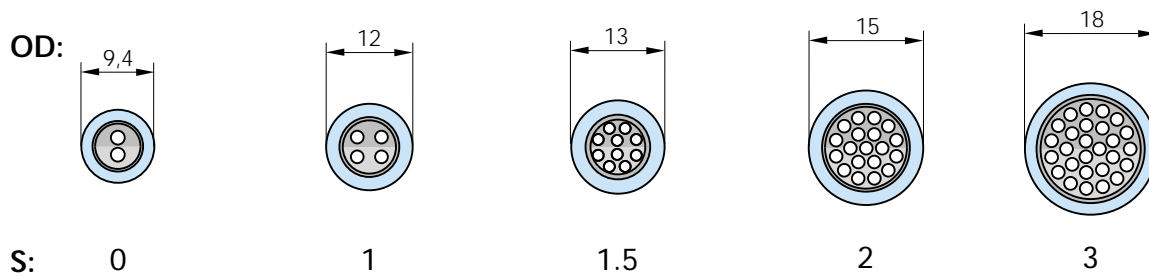

The Part Number Key

Part number key

1	2	3	4	5	6	7	8	9	10	11	12	13	14	15	16	17	18	19
			F			-								-				

1. Type
 - A** = Break-Apart-Plug
Panel Mounted Plug
 - G** = Receptacle
 - K** = In-Line Receptacle
 - S** = Straight Plug
 - W** = Right-Angle Plug
2. Style
 - 1 - 9** and **A**
 - X** = Special
3. Size
 - 0 - 3** and **A**
 - A** = 1,5
4. Series
 - F**
5. Coding (Page 26)
6. Material/Surface - Housing (page26)
7. empty
8. Material - Insulator (Page 27)
9. + 10. Contact Insert (Page 28 - 32)
 - e.g. 18-way = **18**
11. Contact Type/Surface (Page 33)
12. Contact Diameter (Page 33)
 - M** = mixed arrangement
13. + 14. Term. Cross Section (Page 34-35)
 - 14. for special Contact **9**
15. empty
16. + 17. Collet System (Page 36)
18. + 19. Cable Bend Relief (Page 38)

Example:

1	2	3	4	5	6	7	8	9	10	11	12	13	14	15	16	17	18	19
G	5	2	F	1	C	-	T	1	6	L	F	D	0	-	0	0	0	0

Receptacle - Style 5 - Size 2 - Series F - Coding 1 - Brass matt chromate Housing - PBT Insulator - 16pos. - Socket (solder) 0,75 µm Au -Term. Cross Section AWG24/26

1	2	3	4	5	6	7	8	9	10	11	12	13	14	15	16	17	18	19
S	2	2	F	1	C	-	P	1	6	M	F	D	0	-	7	5	E	S

Plug - Style 2 - Size 2 - Series F - Coding 1 - Brass matt chromate Housing - PEEK Insulator - 16pos. - Pin (solder) 0,75 µm Au - Term. Cross Section AWG24/26 - Cable Diameter 7,1-7,5 -Blue Cable Bend Relief - Material Silicone

Part number key

1	2	3	4	5	6	7	8	9	10	11	12	13	14	15	16	17	18	19
			F			-								-				



Straight Plug

(Suitable for all following receptacles and in-line receptacles)

- S 1** - IP 50 – with Standard Back Nut
- S 2** - IP 50 – with Back Nut for Cable Bend Relief*
- S 3** - IP 68 – watertight with Standard Back Nut
- S 4** - IP 68 – watertight with Back Nut for Cable Bend Relief*

contact configuration from page 28

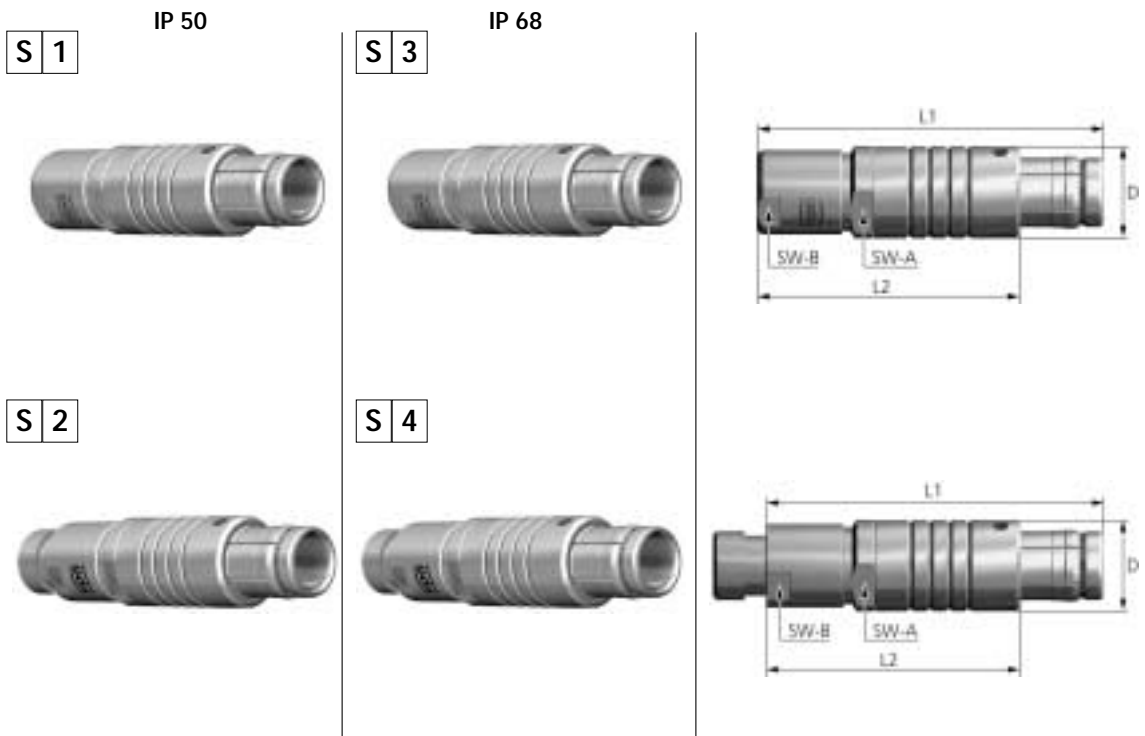

Size	Dimensions in mm				
	L1	L2	D	SW-A	SW-B
0	~ 37	~ 28	9,4	8	7
1	~ 47	~ 35	12	10	10
1,5	~ 48	~ 38	13	11	12
2	~ 50	~ 38	15	13	12
3	~ 60	~ 46	18	16	15

Size	Dimensions in mm				
	L1	L2	D	SW-A	SW-B
0	~ 40	~ 30	9,4	8	7
1	~ 49	~ 38	12	10	10
1,5	~ 50	~ 40	13	11	12
2	~ 53	~ 40	15	13	12
3	~ 62	~ 47	18	16	15

* **Cable Bend Reliefs**
(see page 38)

Part number key

1	2	3	4	5	6	7	8	9	10	11	12	13	14	15	16	17	18	19
			F			-								-				

Right-Angle Plug

(Suitable for all following receptacles and in-line receptacles)

- W 1** - IP 50 – with Standard Back Nut
- W 2** - IP 50 – with Back Nut for Cable Bend Relief*



W 1

contact configuration from page 28



W 2

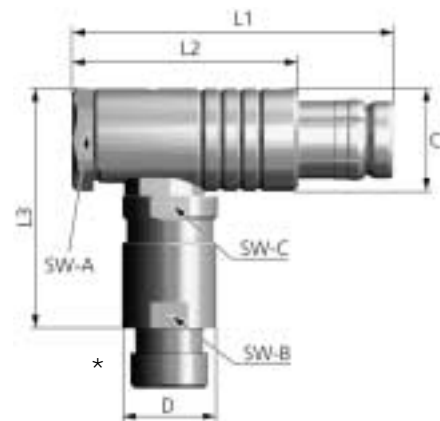

Size	Dimensions in mm							
	L1	L2	L3	C	D	SW-A	SW-B	SW-C
0	~ 33	~ 23	~ 25	10	9	9	7	8
1	~ 37	~ 26,5	~ 33	12	11	11	10	10

* Cable Bend Reliefs
(see page 38)

Part number key

1	2	3	4	5	6	7	8	9	10	11	12	13	14	15	16	17	18	19
			F			-								-			0	0

Break-Apart-Plug (without latching)

(Suitable for all following receptacles and in-line receptacles)

- A 5** - IP 68 – with Standard Back Nut
- A 6** - IP 68 – with Back Nut for Cable Bend Relief*

A 5



contact configuration from page 28

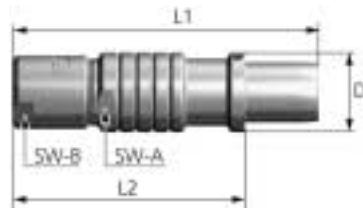

A 6

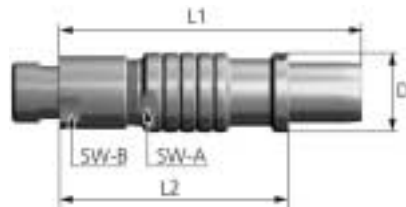

Size	Dimensions in mm				
	L1	L2	D	SW-A	SW-B
3	~ 62	~ 46	17,5	16	15

- A 7** - IP 50 – with Standard Back Nut
- A 8** - IP 50 – with Back Nut for Cable Bend Relief*

A 7



contact configuration from page 28



A 8

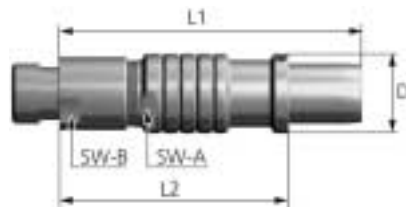

Size	Dimensions in mm				
	L1	L2	D	SW-A	SW-B
0	~ 45,5	~ 35	12	10	10
2	~ 50,5	~ 38	15	13	12

Connector can be separated by pulling the cable.

* **Cable Bend Reliefs**
(see page 38)

Part number key

1	2	3	4	5	6	7	8	9	10	11	12	13	14	15	16	17	18	19
			F			-								-			0	0

Panel mounted plug

(Suitable for all following receptacles and in-line receptacles)

A A - IP 50 – with hex nut, non-latching, installation from front of panel

A A

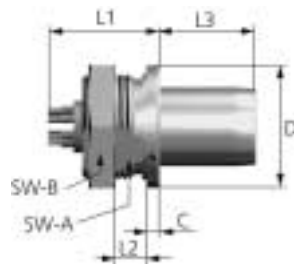

Technical Data

- IP 50
- Anti-rotation feature
- Contact configuration from Page 28 PCB-Layouts from Page 39

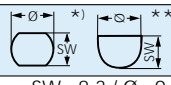
Size	Dimensions in mm							 Panel Cut-Out
	L1	L2 max.	L3	C	D	SW-A	SW-B	
0	12	4	10	1,5	10	8,2	11	SW 8,3 / Ø 9,1 ^{*)}
1	15,5	4,2	10,8	1,5	14	11,1	14	SW 11,2 / Ø 12,1 ^{**)}
2	17,5	3,4	12	2	18	14,1	17	SW 14,2 / Ø 15,1 ^{**)}

Created to build up a docking connection between 2 instruments (E.g. a charging station)

A D - IP 68 – with hex nut, non latching, installation from front of panel

A D

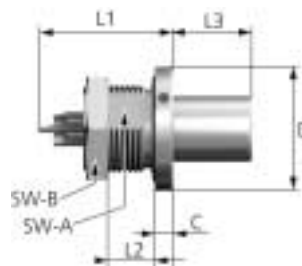

Technical Data

- IP 68
- Anti-rotation feature
- Contact configuration from Page 28 PCB-Layouts from Page 39

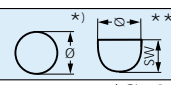
Size	Dimensions in mm							 Panel Cut-Out
	L1	L2 max.	L3	C	D	SW-A	SW-B	
0	13	4,5	10	3	13	9	11	- / Ø 9,1 ^{*)}
1	18,5	6,5	10,8	2,5	17	-	14	SW 11,2 / Ø 12,1 ^{**)}
2	19,7	7	12,1	3	22	-	19	SW 15,3 / Ø 16,1 ^{**)}

Created to build up a docking connection between 2 instruments (E.g. a charging station)

Part number key

1	2	3	4	5	6	7	8	9	10	11	12	13	14	15	16	17	18	19
			F			-								-				



In-Line Receptacle

- K 1** - IP 50 – with Standard Back Nut
- K 2** - IP 50 – with Back Nut for Cable Bend Relief*
- K 3** - IP 68 – watertight with Standard Back Nut
- K 4** - IP 68 – watertight with Back Nut for Cable Bend Relief*

contact configuration from page 28

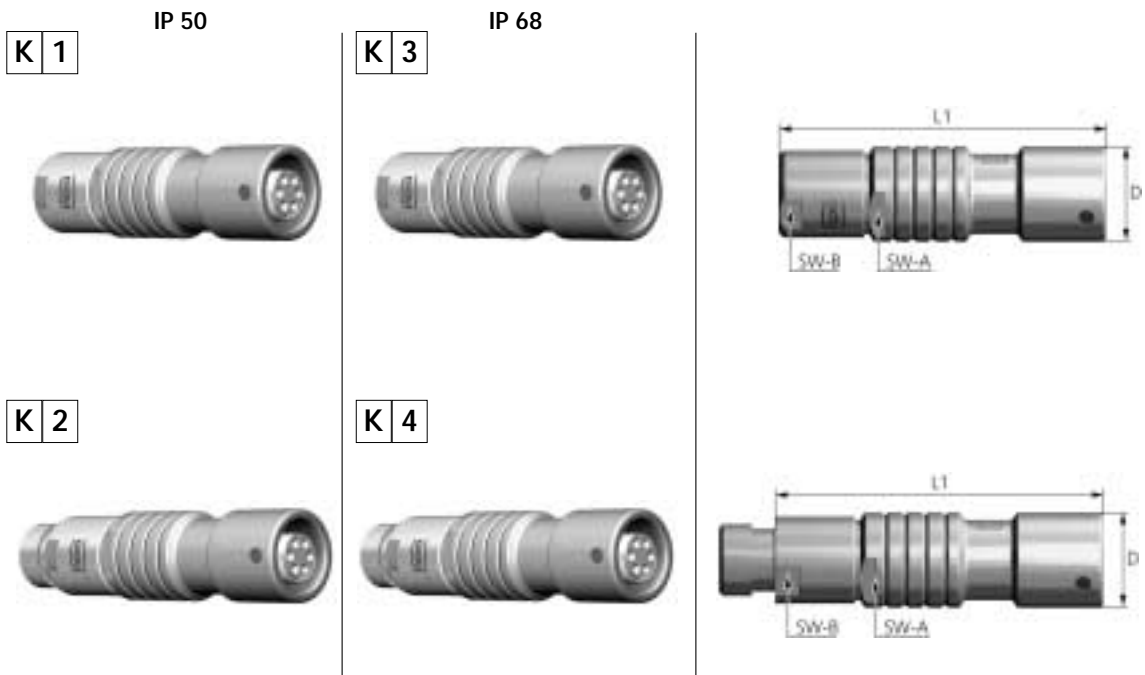

IP 50

Size	Dimensions in mm			
	L1	D	SW-A	SW-B
0	~ 35	9,5	8	7
1	~ 43	12	10	10
2	~ 49	15	13	12
3	~ 58	18	16	15

IP 68

Size	Dimensions in mm			
	L1	D	SW-A	SW-B
0	~ 39	10	8	7
1	~ 47	13	10	10
2	~ 50	16	13	12

* Cable Bend Reliefs
(see page 38)

ODU MINI-SNAP In-line Receptacle connect to plug for cable-to-cable connection.

Part number key

1	2	3	4	5	6	7	8	9	10	11	12	13	14	15	16	17	18	19
			F			-								-				

¹⁾ L1 = Maximum Length incl. Contact Insert
²⁾ L3 = Length of Housing
³⁾ =min. wallthickness without using a distance ring

Receptacle

G 1 **Style 1** – ODU MINI-SNAP RECEPTACLE IP 50, installation from front of panel

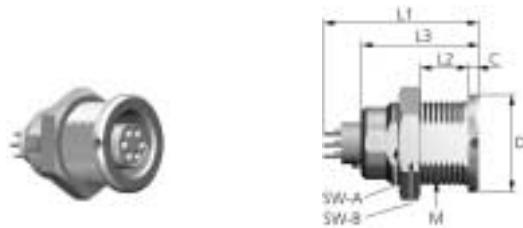

Technical Data

- IP 50
- Anti-rotation feature
- Contact configuration from Page 28
PCB-Layouts from Page 39

Size	Dimensions in mm									Panel Cut-Out
	¹⁾ L1	L2 max.	²⁾ L3	M	D	SW-A	SW-B	C		
0	~ 20,0	~ 9,0	14,5	9x0,5	10,0	8,2	11,0	1,5		SW 8,3 / Ø 9,1 [*]
1	~ 24,0	~ 8,0	16,5	12x1	14,0	10,0	14,0	1,5		SW 10,1 / Ø 12,1 [*]
2	~ 27,0	~ 10,0	18,5	15x1	18,0	14,1	17,0	2,0		SW 14,2 / Ø 15,1 ^{**}
3	~ 30,5	~ 13,0	22,5	18x1	22,0	16,5	22,0	2,0		SW 16,6 / Ø 18,1 [*]

G 2 **Style 2** – ODU MINI-SNAP WATERTIGHT RECEPTACLE IP 68*, installation from front of panel

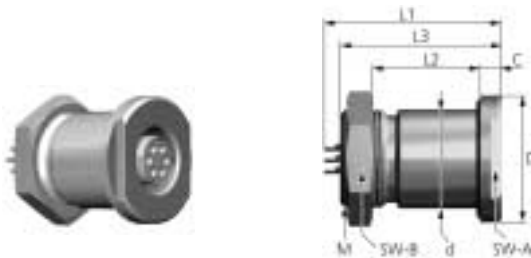

Technical Data

- IP 68
- Contact configuration from Page 28
PCB-Layouts from Page 39
- Distance ring for wall-thickness adjustment, see accessories page 52

Size	Dimensions in mm										Panel Cut-Out
	¹⁾ L1	³⁾ L2max.	²⁾ L3	M	D	SW-A	SW-B	C	d		
0	~ 22,5	8,0	18,5	9x0,5	14,5	11,0	11,0	3,0	10,0		Ø 10,1
1	~ 26,0	9,0	22,5	14x1	18,0	14,0	17,0	3,0	14,0		Ø 14,1
2	~ 29,0	8,0	23,0	16x1	22,0	17,0	19,0	4,0	16,0		Ø 16,1
3	~ 32,0	~ 32,0	26,5	20x1	26,0	24,0	25,0	4,0	20,0		Ø 20,1

G 4 **Style 4** – ODU MINI-SNAP WATERTIGHT RECEPTACLE IP 68*, installation from front of panel with low rear profile

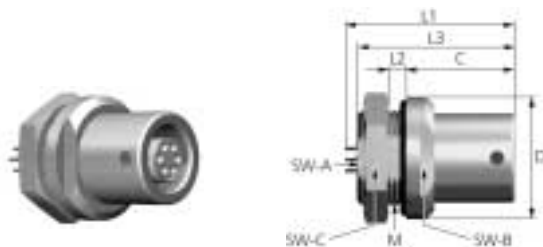

Technical Data

- IP 68
- Anti-rotation feature
- Contact configuration from Page 28
PCB-Layouts from Page 39

Size	Dimensions in mm										Panel Cut-Out
	¹⁾ L1	L2max.	²⁾ L3	M	D	SW-A	SW-B	SW-C	C		
0	~ 22,5	~ 5,0	17,5	9x0,5	14,5	8,2	12,0	11,0	11,0		SW 8,3 / Ø 9,1
1	~ 26,0	~ 4,0	22,5	14x1	18,0	12,0	14,0	17,0	15,5		SW 12,1 / Ø 14,1
1,5	~ 28,0	~ 5,0	21,6	14x1	19,0	12,0	15,0	17,0	13,6		SW 12,1 / Ø 14,1

*Reference: Potted Receptacle please see page 71 III

Part number key

1	2	3	4	5	6	7	8	9	10	11	12	13	14	15	16	17	18	19
			F			-								-				

¹⁾ L1 = Maximum Length incl. Contact Insert
²⁾ L3 = Length of Housing

Receptacle

G 5 Style 5 – ODU MINI-SNAP RECEPTACLE IP 50, CONTINUOUS THREAD, installation from rear or front of panel. Front extension adjustable

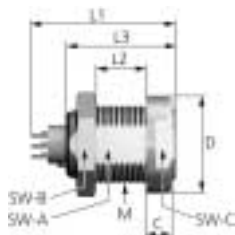

Technical Data

- IP 50
- Anti-rotation feature
- Contact configuration from Page 28
PCB-Layouts from Page 39

Size	Dimensions in mm									Panel Cut-Out
	¹⁾ L1	L2 max.	²⁾ L3	M	D	SW-A	SW-B	SW-C	C	
0	~ 20,0	~ 8,0	14,5	9x0,5	11,5	8,0	11,0	10,0	2,5	SW 8,1 / Ø 9,1
1	~ 24,0	~ 8,0	16,5	12x1	15,0	10,0	14,0	13,0	4,0	SW 10,1 / Ø 12,1
1,5	~ 24,0	~ 8,0	15,5	14x1	19,0	12,0	17,0	17,0	3,0	SW 12,1 / Ø 14,1
2	~ 27,5	~ 10,0	18,5	15x1	20,0	13,5	17,0	17,0	4,0	SW 13,6 / Ø 15,1
3	~ 30,5	~ 14,0	22,5	18x1	23,0	16,5	22,0	20,0	5,0	SW 16,6 / Ø 18,1

Receptacle

G 8 Style 8 – ODU MINI-SNAP WATERTIGHT RECEPTACLE IP 68*, with slotted nut, installation from rear of panel

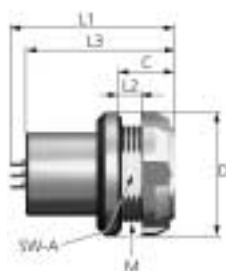

Technical Data

- IP 68
- Anti-rotation feature
- Contact configuration from Page 28
PCB-Layouts from Page 39
- nutdriver for slotted mounting nut, see page 62

Size	Dimensions in mm							Panel Cut-Out
	¹⁾ L1	L2 max.	²⁾ L3	M	D	C	SW-A	
0	~ 22,0	~ 3,5	17,0	9x0,5	14,0	6,5	8,2	SW 8,3 / Ø 9,1 **)
1	~ 27,5	~ 4,0	21,0	14x1	18,0	8,0	12,0	SW 12,1 / Ø 14,1 *)
1,5	~ 24,0	~ 3,0	19,5	14x1	19,0	7,0	12,0	SW 12,1 / Ø 14,1 *)
2	~ 29,0	~ 3,0	23,0	16x1	21,0	8,0	14,3	SW 14,6 / Ø 16,1 *)
3	~ 33,0	~ 6,0	26,5	20x1	26,0	11,0	18,0	SW 18,1 / Ø 20,1 *)

*Reference: Potted Receptacle please see page 71 III.

Part number key

1	2	3	4	5	6	7	8	9	10	11	12	13	14	15	16	17	18	19
			F			-								-				

¹⁾ L1 = Maximum Length incl. Contact Insert
²⁾ L3 = Length of Housing

Receptacle

G B **Style B** – ODU-MINI-SNAP RECEPTACLE IP 50 (similar style 1), with grounding tab, installation from front of panel

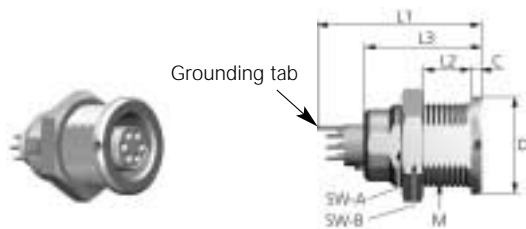

Technical Data

- IP 50
- Anti-rotation feature
- Contact configuration from Page 28 PCB-Layouts from Page 39

Size	Dimensions in mm								Panel Cut-Out
	¹⁾ L1	L2 max.	²⁾ L3	M	D	SW-A	SW-B	C	
0	~20,7	~ 9,0	14,5	9x0,5	10,0	8,2	11,0	1,5	SW 8,3 / Ø 9,1
1	~24,2	~10,0	16,5	12x1	14,0	10,0	14,0	1,5	SW 10,1 / Ø 12,1

G C **Style C** – ODU-MINI-SNAP RECEPTACLE IP 50, installation from rear of panel

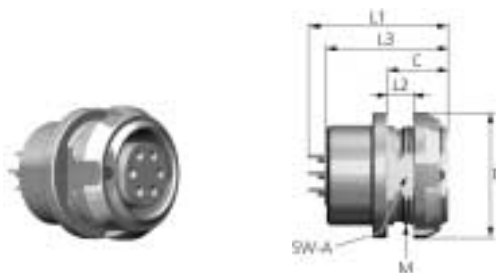

Technical Data

- IP 50
- Anti-rotation feature
- Contact configuration from Page 28 PCB-Layouts from Page 39
- nutdriver for slotted mounting nut, see page 62

Size	Dimensions in mm							Panel Cut-Out	
	¹⁾ L1	L2 max.	²⁾ L3	M	D	SW-B	C	Ø*	Ø***)
1,5	~22,5	~ 3,0	17,0	14x1	18,0	12,0	7,0	SW 12,1 / Ø 14,1*)	
2	~26,9	~ 5,0	18,0	15x1	19,0	14,0	9,0	SW 14,35 / Ø 15,1***)	
3	~31,3	~12,0	22,0	18x1	23,0	17,2	17,0	SW 17,3 / Ø 18,1***)	

G D **Style D** – ODU-MINI-SNAP RECEPTACLE IP 68*, with round nut, installation from rear of panel

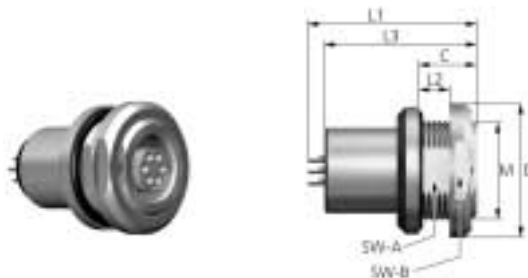

Technical Data

- IP 68
- Anti-rotation feature
- Contact configuration from Page 28 PCB-Layouts from Page 39

Size	Dimensions in mm								Panel Cut-Out
	¹⁾ L1	L2 max.	²⁾ L3	M	D	SW-A	SW-B	C	
1	~27,0	~ 5,0	21,0	14x1	19,0	12,0	17,0	8,0	SW 12,1 / Ø 14,1

*Reference: Potted Receptacle please see page 71 III.

Part number key

1	2	3	4	5	6	7	8	9	10	11	12	13	14	15	16	17	18	19
			F			-									-			

¹⁾ L1 = Maximum Length incl. Contact Insert
²⁾ L3 = Length of Housing

Receptacle

G H **Bauform H** – ODU MINI-SNAP RECEPTACLE IP 50, installation from front of panel

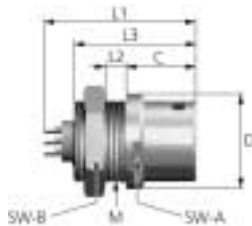

Technical Data

- IP 50
- Anti-rotation feature
- Contact configuration from Page 28
PCB-Layouts from Page 39

Size	Dimensions in mm								Panel Cut-Out
	¹⁾ L1	L2 max.	²⁾ L3	M	D	SW-A	SW-B	C	
0	~19,3	~ 3,0	16,0	9x0,5	10,9	-	11,0	10,0	SW 8,2 / Ø 9,1
1	~24,0	~ 4,5	17,5	12x1	14,0	12,0	14,0	7,5	SW 10,4 / Ø 12,1
1,5	~26,0	~ 5,0	17,0	14x1	18,0	15,0	17,0	9,0	SW 12,1 / Ø 14,1
2	~27,0	~ 5,5	19,5	16x1	19,0	17,0	19,0	11,0	SW 13,6 / Ø 16,1

G Q **Style Q** – ODU-MINI-SNAP RECEPTACLE IP 50, CONTINUOUS THREAD, (see Style 5, but 2 special nuts) installation from rear or front of panel. Extension in front of panel is adjustable

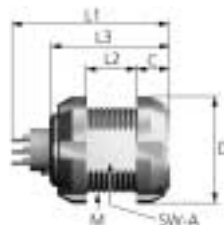

Technical Data

- IP 50
- Anti-rotation feature
- Contact configuration from Page 28
PCB-Layouts from Page 39
- Nutdriver Page 62

Size	Dimensions in mm							Panel Cut-Out
	¹⁾ L1	L2 max.	²⁾ L3	M	D	SW-A	C	
0	~20,0	~ 7,0	14,5	9x0,5	12,0	8,0	3,0	SW 8,1 / Ø 9,1
1	~24,0	~ 7,0	16,5	12x1	15,0	10,0	4,0	SW 10,1 / Ø 12,1
1,5	~24,7	~ 7,0	15,5	14x1	18,0	12,0	4,0	SW 12,1 / Ø 14,1

Details for the Part Number Key Series F

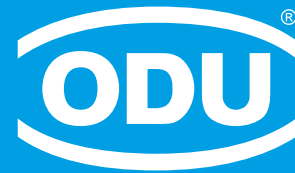
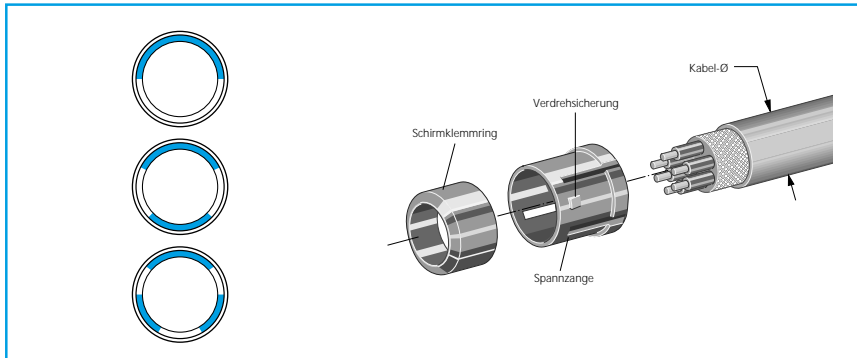

Keying
Housing Materials / Surfaces
Inserts
Collet System
Bend Protection Sleeves



Coding

Part number key

1	2	3	4	5	6	7	8	9	10	11	12	13	14	15	16	17	18	19
			F			-								-				



Serie F

Angle	Receptacle Front View	Size				
		0	1	1,5	2	3
1		●	●	●	●	●
2		●	●	●	●	●
3				●	○	●

● Standard
○ On request

Housing Materials / Surfaces

Part number key

1	2	3	4	5	6	7	8	9	10	11	12	13	14	15	16	17	18	19
			F			-								-				

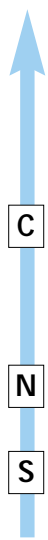

Standard

C Cu-alloy / matt chromate

Special materials and surfaces on request.

N

Cu-alloy / nickel

S

Cu-alloy / black chromate

Insulation Body Material

Part number key

1	2	3	4	5	6	7	8	9	10	11	12	13	14	15	16	17	18	19
			F			-								-			0	0



T PBT

P PEEK

Additional materials on request

Turned Contacts

Article Number	PBT	PEEK
Solder Termination	✓	✓
Crimp Termination	✓	✓*
PCB Termination	✓	✓

✓ = available

* = Crimp-Clip contacts with 0,7 mm diameter are available.

Advice for insulation body selection regarding PCB termination:

wave-solder: PBT or PEEK insulation body.

All other methods: only PEEK insulation body.

Size 0

Part number key

1	2	3	4	5	6	7	8	9	10	11	12	13	14	15	16	17	18	19
			F				-								-			

Standard Contact Configuration	Size	Positions		Contact Ø mm	Nominal Signal Contact Current Load in A (Derating factor see page 74)	Test Voltage acc. VDE 0627:1986-06 (kVeff)	Test Voltage acc. SAE AS13441:1998 method 3001.1 (kVeff)	Nominal Voltage acc. SAE AS13441:1998 method 3001.1 (kVrms) ¹⁾	Termination			View on termination side	
		0	2						Solder	Crimp (Tools for assembling see page 56)	Print (PCB layout see page 39)	Pin part	Socket
	0	0	2	0,9	10	1,000	1,500	0,500	●	●	●		
	0	0	3	0,9	10	0,875	1,200	0,400	●	●	●		
	0	0	4	0,7	7	0,875	0,900	0,300	●	●	●		
	0	0	5	0,7	7	0,750	1,100	0,366	●	●	●		
	0	0	7	0,5	5	1,000	0,900	0,300	●	●	●		

1) Nominal Voltage acc. SAE AS 13441:1998 method 3001.1 meet the MIL-STD 1344, method 3001, Test acc. IEC 60512 test 4a.
Method of calculation, utilization warning and Proposals see page 73.
2) only in PEEK available.
3) Crimp-Clip inserts are only available in PEEK.

Size 1

Part number key

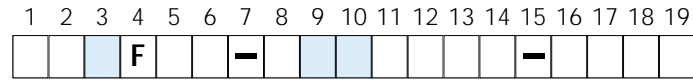

Standard Contact Configuration	Size	Positions		Contact Ø mm	Nominal Signal Contact Current Load in A (Derating factor see page 74)	Test Voltage acc. VDE 0627:1986-06 (kVeff)	Test Voltage acc. SAE AS13441:1998 method 3001.1 (kVeff)	Nominal Voltage acc. SAE AS13441:1998 method 3001.1 (kVrms) ¹⁾	Termination			View on termination side	
		0	2						Solder	Crimp (Tools for assembling see page 56)	Print (PCB layout see page 39)	Pin part	Socket
	1	0	2	1,3	14	1,250	1,650	0,550	●	●	●		
	1	0	3	1,3	14	1,000	1,500	0,500	●	●	●		
	1	0	4	0,9	10	1,000	1,500	0,500	●	●	●		
	1	0	5	0,9	10	0,875	1,350	0,450	●	●	●		
	1	0	6	0,7	7	0,875	1,200	0,400	●	●	●		
	1	0	7	0,7	7	0,875	1,200	0,400	●	●	●		
	1	1	2	0,5	5	0,750	1,100	0,366	●		● ²⁾		

1) Nominal Voltage acc. SAE AS 13441:1998 method 3001.1 meet the MIL-STD 1344, method 3001, Test acc. IEC 60512 test 4a.
Method of calculation, utilization warning and Proposals see page 73.

2) Only socket part available.

3) Crimp-Clip inserts are only available in PEEK

Size 1,5

Part number key

1	2	3	4	5	6	7	8	9	10	11	12	13	14	15	16	17	18	19
		F				-								-				

Standard Contact Configuration	Size	Positions	Positions	Contact Ø mm	Nominal Signal Contact Current Load in A (Derating factor see page 74)	Test Voltage acc. VDE 0627:1986-06 (kVeff)	Test Voltage acc. SAE AS13441:1998 method 3001.1 (kVeff)	Nominal Voltage acc. SAE AS13441:1998 method 3001.1 (kVrms) ¹⁾	Termination			View on termination side	
									Solder	Crimp (tools for assembling see page 56)	Print (PCB layout see page 39)	Pin part	Socket
A		1	0	0,7	7	0,875	1,200	0,400	●		●		
A		1	2	0,7	7	0,875	1,200	0,400	●	●	●		
A		1	9	0,5	14	0,750	1,000	0,333	●	●	●		

1) Nominal Voltage acc. SAE AS 13441:1998 method 3001.1 meet the MIL-STD 1344, method 3001, Test acc. IEC 60512 test 4a.

Method of calculation, utilization warning and Proposals see page 73.

2) Crimp-Clip inserts are only available in PEEK

Size 2

Part number key

1	2	3	4	5	6	7	8	9	10	11	12	13	14	15	16	17	18	19
		F				-								-				

Standard Contact Configuration	Size	Positions		Contact Ø mm	Nominal Signal Contact Current Load in A (Derating factor see page 74)	Test Voltage acc. VDE 0627:1986-06 (kVeff)	Test Voltage acc. SAE AS13441:1998 method 3001.1 (kVeff)	Nominal Voltage acc. SAE AS13441:1998 method 3001.1 (kVrms) ¹⁾	Termination			View on termination side	
		0	5						Solder	Crimp (Tools for assembling see page 56)	Print (PCB layout see page 40)	Pin part	Socket
	2	0	5	1,3	14	1,000	1,500	0,500	●	●	●		
	2	0	6	0,9	10	1,250	1,800	0,600	●	●	●		
	2	1	1	0,9	10	0,875	1,350	0,450	●	●	●		
	2	1	6	0,7	7	0,875	1,350	0,450	●	●	●		
	2	1	9	0,7	7	0,750	1,200	0,400	●	●	●		

1) Nominal Voltage acc. SAE AS 13441:1998 method 3001.1 meet the MIL-STD 1344, method 3001, Test acc. IEC 60512 test 4a. Method of calculation, utilization warning and Proposals see page 73.

2) Crimp-Clip inserts are only available in PEEK

Size 3

Part number key

1	2	3	4	5	6	7	8	9	10	11	12	13	14	15	16	17	18	19
		F				-								-				

Standard Contact Configuration	Size	Positions		Contact Ø mm	Nominal Signal Contact Current Load in A (Derating factor see page 74)	Test Voltage acc. VDE 0627:1986-06 (kVeff)	Test Voltage acc. SAE AS13441:1998 method 3001.1 (kVeff)	Nominal Voltage acc. SAE AS13441:1998 method 3001.1 (kVrms) ¹⁾	Termination			View on termination side	
		1	2						Solder	Crimp (Tools for assembling see page 56)	Print (PCB layout see page 40)	Pin part	Socket
3	3	1	2	1,3	14	0,875	1,350	0,450	●	●	●		
3	3	1	5	0,9	10	0,875	1,350	0,450	●	●	●		
3	3	2	4	0,7	7	0,750	1,000	0,333	●	●	●		
3	3	2	7	0,7	7	0,750	1,000	0,333	●	●	●		

1) Nominal Voltage acc. SAE AS 13441:1998 method 3001.1 meet the MIL-STD 1344, method 3001, Test acc. IEC 60512 test 4a.

Method of calculation, utilization warning and Proposals see page 73.

2) Crimp-Clip inserts are only available in PEEK

Contact Type / Contact Surface - Contact Diameter

Part number key

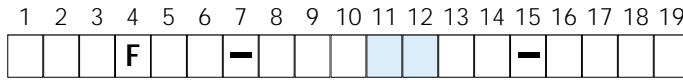

Type	Surface
Socket	L - 0,75 µm Au (min.)
Pin	L - 0,75 µm Au (min.)
Socket	C- 0,75 µm Au (min.)
Pin	C - 0,75 µm Au (min.)
Socket	P - 0,75 µm Au (min.)
Pin	P - 0,75 µm Au (min.)

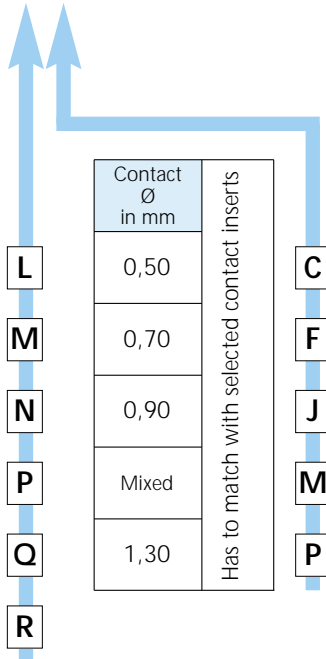

Contact Ø in mm	Has to match with selected contact inserts
0,50	
0,70	
0,90	
Mixed	
1,30	

- L = Solder termination
- C = Crimp termination
- P = PCB termination

Contact Termination Cross Sections

Part number key

1	2	3	4	5	6	7	8	9	10	11	12	13	14	15	16	17	18	19
			F			-								-			0	0

Crimp Contact

Contact Ø	Size	AWG	mm ²	
0,7	0	24/26	0,25/0,15	D 0
0,7	0	22	0,38	G 0
0,9	0	24/26	0,25/0,15	D 0
0,9	0	22	0,38	G 0
0,7	1	24/26	0,25/0,15	D 0
0,7	1	22	0,38	G 0
0,9	1	24/26	0,25/0,15	D 0
0,9	1	20/22	0,50/0,38	H 0
1,3	1	18	1,0	L 0
0,7	1,5	24/26	0,25/0,15	D 0
0,7	1,5	22	0,38	G 0
0,7	2	24/26	0,25/0,15	D 0
0,7	2	22	0,38	G 0
0,9	2	24/26	0,25/0,15	D 0
0,9	2	20/22	0,50/0,38	H 0
1,3	2	18	1,0	L 0
0,7	3	24/26	0,25/0,15	D 0
0,7	3	22	0,38	G 0
0,7	3	28/30	0,08/0,05	C 0
0,9	3	24/26	0,25/0,15	D 0
0,9	3	20/22	0,50/0,38	H 0
1,3	3	18	1,0	L 0



Tools for crimping and adjustments
see page 56 to 61

Contact Termination Cross Sections

Part number key

1	2	3	4	5	6	7	8	9	10	11	12	13	14	15	16	17	18	19
			F			-								-			0	0

Solder Contact

Contact Ø	Term. Ø	Term. Cross	
		AWG	mm ²
0,5	0,4	28	0,08
0,7	0,6	26	0,15
0,7	0,85	22	0,38
0,9	0,85	22	0,38
1,3	1,1	20	0,50



C	0
D	0
G	0
G	0
H	0

PCB Contact

Contact Ø	Term. Ø
0,5	0,5
0,7	0,5
0,9	0,7
1,3	0,7

0	0
0	0
0	0
0	0

Please see the PCB-layouts on page 39-40.

For mixed inserts

0	0
---	---

(Please provide details of termination cross section!)

Collet System

Part number key

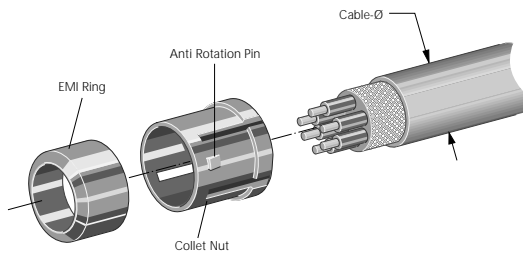

1	2	3	4	5	6	7	8	9	10	11	12	13	14	15	16	17	18	19
			F			-								-				

Insert: for all Plugs and In-Line receptacles.

Application: **Collet nut** for strain relief, **EMI ring** for conductive path between shield and housing.

Cable diameter in mm	Size				
	0	1	1,5	2	3
> 1,0 - 1,5	●	●			
> 1,5 - 2,0	●	●			
> 2,0 - 2,5	●	●		●	
> 2,5 - 3,0	●	●	●	●	
> 3,0 - 3,5	●	●	●	●	●
> 3,5 - 4,0	●	●	●	●	●
> 4,0 - 4,5	●	●	●	●	●
> 4,5 - 5,0	●	●	●	●	●
> 5,0 - 5,5		●	●	●	●
> 5,5 - 6,0		●	●	●	●
> 6,0 - 6,5		●	●	●	●
> 6,5 - 7,0		●	●	●	●
> 7,0 - 7,5		●	●	●	●
> 7,5 - 8,0				●	●
> 8,0 - 8,5				●	●
> 8,5 - 9,0				●	●
> 9,0 - 9,5				●	●
> 9,5 - 10,0					●
> 10,0 - 10,5					●
> 10,5 - 11,5					●
without collet system					

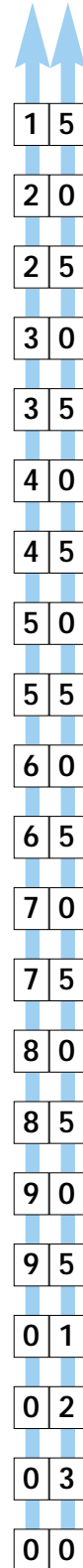

Right-Angled Print Contacts in the Receptacle

Part number key

1	2	3	4	5	6	7	8	9	10	11	12	13	14	15	16	17	18	19
			F			-								-			0	0

Right-Angled Print Contact

A

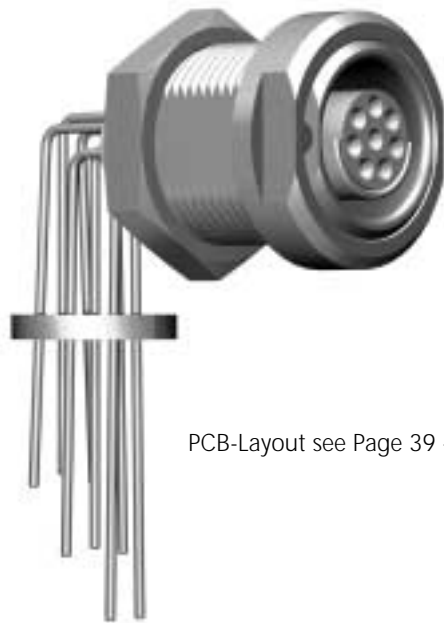

PCB-Layout see Page 39 - 40

Cable Bend Reliefs



PUR

Temperature range
PUR -40 °C up to +80 °C
short term up to +120 °C

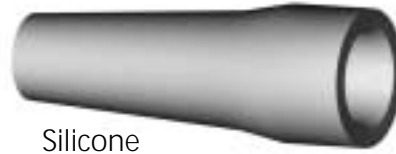

Silicone

Temperature range
Silicone -50 °C up to +200 °C
short term up to +230 °C
autoclavable

Part number key

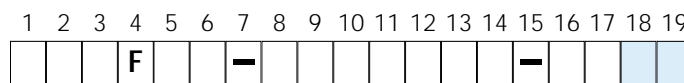

Color of the Cable Bend Relief

Color / RAL-number (similar)	
red	RAL 3020
white	RAL 9010
yellow	RAL 1016
green	RAL 6029
blue	RAL 5002
grey	RAL 7005
black	RAL 9005
* orange	RAL 2004
* purple	RAL 4005
* brown	RAL 8016
* light green	RAL 6018
* light blue	RAL 5012
without cable bend relief	

* = only available in PUR





Material of the Cable Bend Relief

Material/Substance
Silicone
PUR
without cable bend relief

A
B
C
D
E
F
G
H
J
K
L
M
O

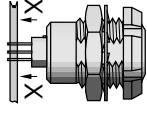
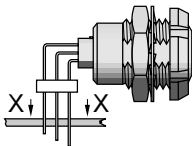
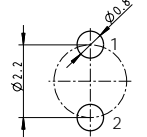
S
P
O

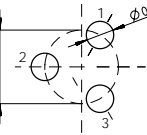
Drilling Patterns for PCB-contacts

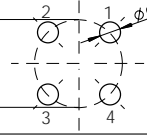
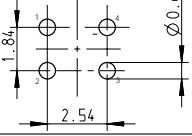
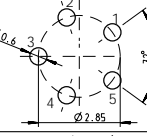
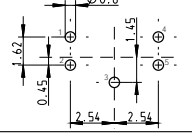
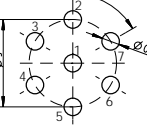
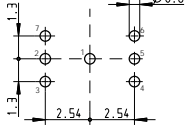
	Straight	90° right-angled
Size 0		
2-way		
3-way		
4-way		
5-way		
7-way		

Drilling Patterns for PCB-contacts

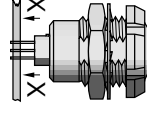
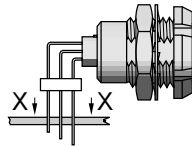
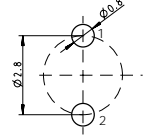
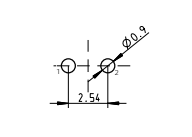
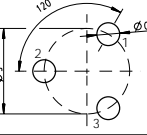
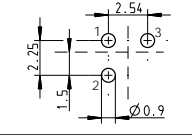
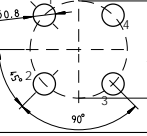
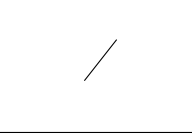
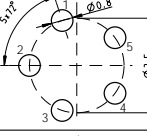
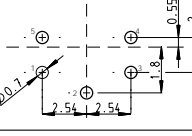
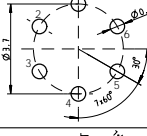
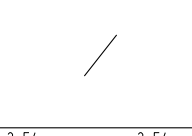
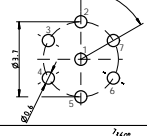
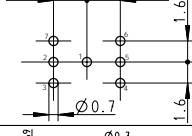
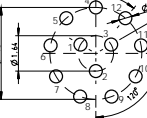
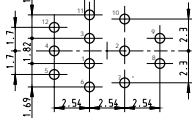
	Straight	90° right-angled
Size 1		
2-way		
3-way		
4-way		
5-way		
6-way		
7-way		
12-way		

All declarations are legal for socket inserts. Pin inserts on request.

Drilling Patterns for PCB-contacts

	Straight	90° right-angled
Size 1,5		
10-way		
12-way		
19-way		

Drilling Patterns for PCB-contacts

	Straight	90° right-angled
Size 3		
12-way		/
15-way		/
24-way		/
27-way		/

Drilling Patterns for PCB-contacts

	Straight	90° right-angled
Size 2		
6-way		/
8-way		/
11-way		
16-way		

All declarations are legal for socket inserts. Pin inserts on request.

Special Solutions



Customer specific solutions for ODU MINI-SNAP

ODU as a specialist for customized solutions have all main competences under one roof.

Development, an own tool shop, stamping, molding, surface plating, manufacturing of complete assembly machines etc. etc. .

With all these possibilities we are able to offer "Custom tailored" solutions for our customers.

When do we actively pursue customer specific solutions?

First we have to study the customers requirements. Here we would appreciate a precise technical specification and figures on quantities!

With all these informations we decide whether we take this project or not.

Most important is that the project potential will justify all the effort we have to put in!

After all these questions are clarified we are ready to go.

Custom Specific Inserts



Special insulators and special assemblings for High-Voltage applications



Custom specific PCB assembling

Special overmouldings and insulation sleeves



Also different locking mechanisms are possible (picture: Bajonett and Threaded Locking)



Accessories

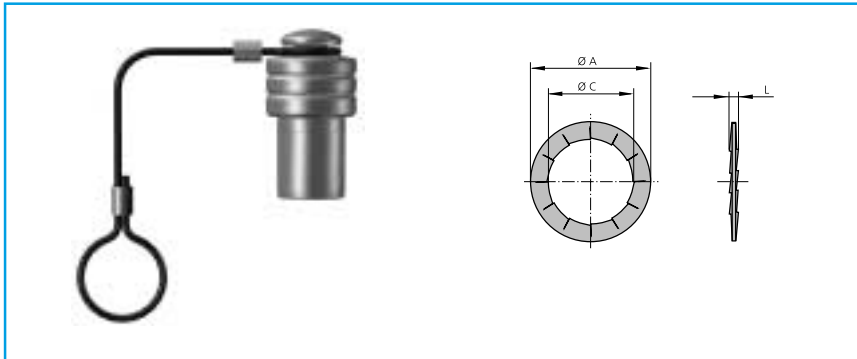

Color Coding Ring

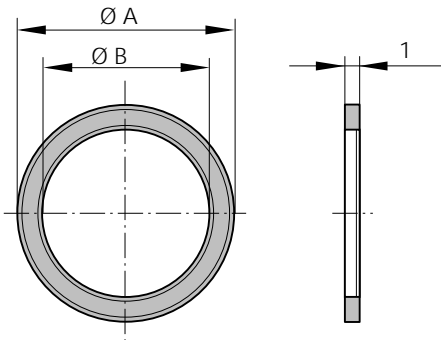

Mounting Example:

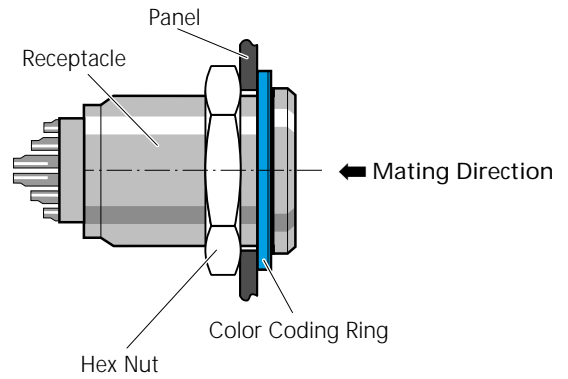

Order Example

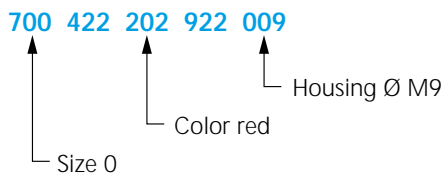

* = In ... please indicate color code

Size

Size	Part Number with Colour	Ø A	Ø B
0	700 422 ... 922 009	13,5	9,1
0	700 422 ... 922 010	16,5	10,1
1	701 422 ... 922 012	17,0	12,1
1	701 422 ... 922 014	20,0	14,1
1,5	715 422 ... 922 014	21,0	14,1
2	702 422 ... 922 015	22,0	15,1
2	702 422 ... 922 016	23,0	16,1
3	703 422 ... 922 018	25,0	18,1
3	703 422 ... 922 020	28,0	20,1

Color

Part Number with color	Color	RAL-No. (similar)
202	red	3020
203	white	9010
204	yellow	1016
205	green	6029
206	blue	5002
207	grey	7005
208	black	9005
209	orange	2004
210	violet	4005
212	brown	8016
215	light green	6018
216	light blue	5012

Because of different raw materials the colors may slightly differ from RAL numbers.

Protective Covers for Receptacles (IP 50)

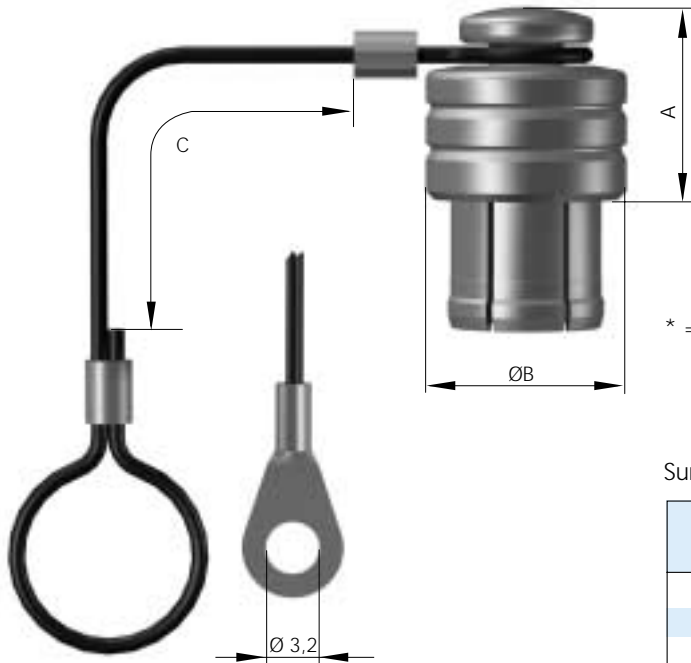

* = With . please, register desired lanyard material
 0 = Polyamide lanyard with loop
 1 = Stainless steel lanyard with loop
 2 = Polyamide lanyard solder lug
 3 = Stainless steel lanyard solder lug

Surface: Matt chromate

Size	Part Number*	Dimensions in mm		
		A	B	C
0	700 097 003 215 .00	9,55	10	70
1	701 097 003 215 .00	11,5	12	75
1,5	715 097 003 215 .00	13,0	13	80
2	702 097 003 215 .00	14,85	15	85
3	703 097 003 215 .00	17,1	18	100

Protective Covers for Receptacles (IP 68)

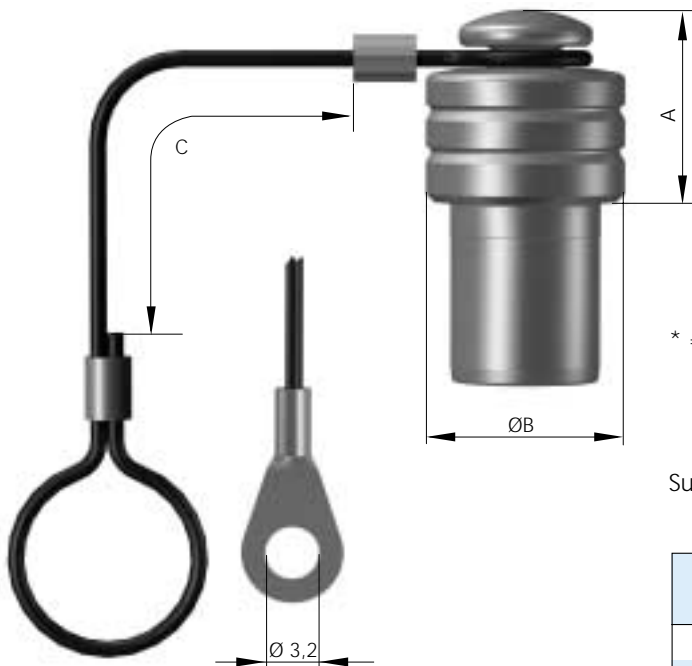

* = With . please, register desired lanyard material
 0 = Polyamide lanyard with loop
 1 = Stainless steel lanyard with loop
 2 = Polyamide lanyard solder lug
 3 = Stainless steel lanyard solder lug

Surface: Matt chromate

Size	Part Number*	Dimensions in mm		
		A	B	C
0	700 097 006 215 .00	9,5	10	70
1	701 097 006 215 .00	11,5	12	75
1,5	715 097 006 215 .00	13,0	13	80
2	702 097 006 215 .00	14,85	15	85
3	703 097 006 215 .00	17,1	18	100

Protective Covers for Plugs (IP 50)

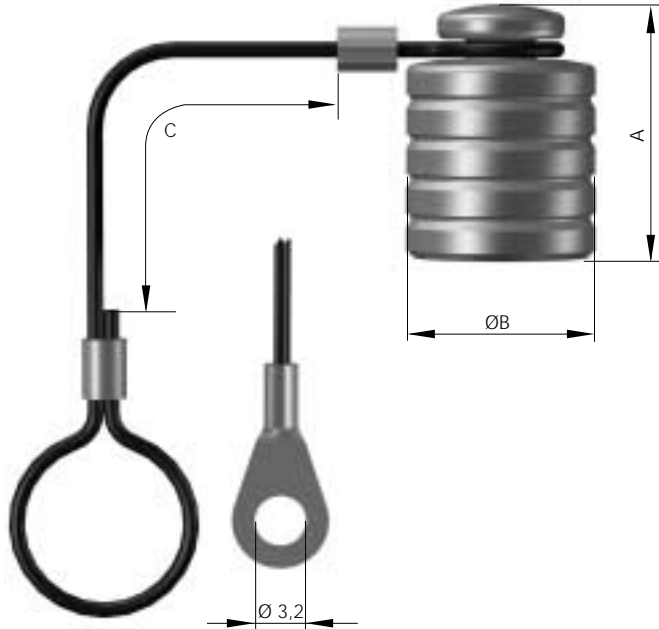

* = With . please, register desired lanyard material
 0 = Polyamide lanyard with loop
 1 = Stainless steel lanyard with loop
 2 = Polyamide lanyard solder lug
 3 = Stainless steel lanyard solder lug
 Surface: Matt chromate

Size	Part Number*	Dimensions in mm		
		A	B	C
0	700 097 005 215 .00	15	10	70
1	701 097 005 215 .00	16	12	75
1,5	715 097 005 215 .00	15	13	80
2	702 097 005 215 .00	18	15	85
3	703 097 005 215 .00	21	18	100

Protective Covers for Plugs (IP 68)

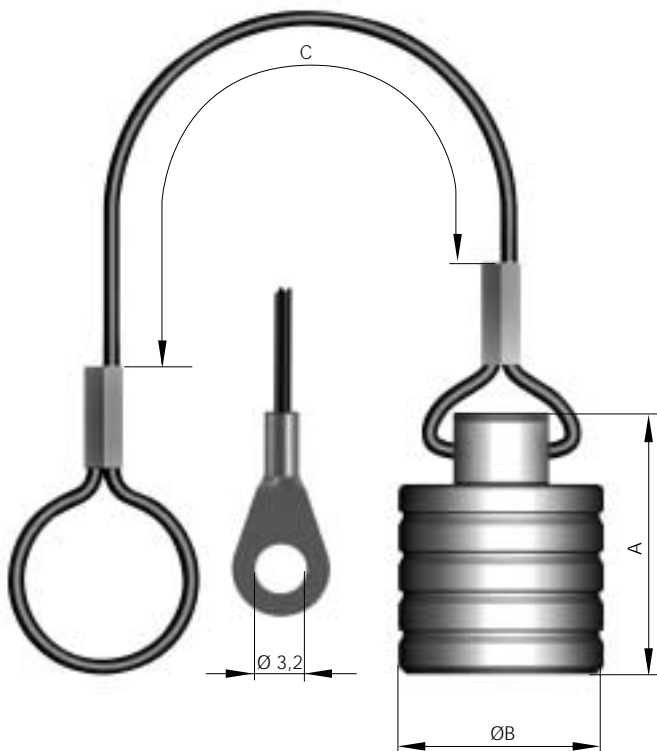

* = With . please, register desired lanyard material
 0 = Polyamide lanyard with loop
 1 = Stainless steel lanyard with loop
 2 = Polyamide lanyard solder lug
 3 = Stainless steel lanyard solder lug
 Surface: Matt chromate

Size	Part Number*	Dimensions in mm		
		A	B	C
0	700 097 004 215 .00	15	10,5	70
1	701 097 004 215 .00	16	13	75
1,5	715 097 004 215 .00	15	13,5	80
2	702 097 004 215 .00	18	16	85
3	703 097 004 215 .00	21	19	100

Silicone-Cable Bend Relief

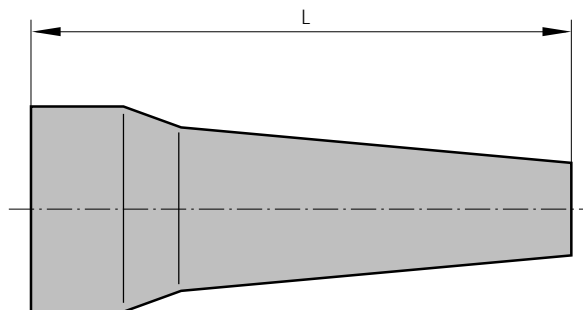

* = In ... please indicate color code

Size	Part Number*	Dim. L	Cable O.D.	
			min.	max.
0	700 023 ... 965 020	27	> 2,0	2,5
0	700 023 ... 965 025	27	> 2,5	3,0
0	700 023 ... 965 030	27	> 3,0	3,5
0	700 023 ... 965 035	27	> 3,5	4,0
0	700 023 ... 965 040	27	> 4,0	4,5
0	700 023 ... 965 045	27	> 4,5	5,0
1	701 023 ... 965 025	30	> 2,5	3,0
1	701 023 ... 965 030	30	> 3,0	3,5
1	701 023 ... 965 035	30	> 3,5	4,0
1	701 023 ... 965 040	30	> 4,0	5,0
1	701 023 ... 965 050	30	> 5,0	6,0
1	701 023 ... 965 060	30	> 6,0	6,5
1	701 023 ... 965 070	30	> 6,5	7,5
2	702 023 ... 965 030	36	> 3,0	3,5
2	702 023 ... 965 035	36	> 3,5	4,0
2	702 023 ... 965 040	36	> 4,0	5,0
2	702 023 ... 965 050	36	> 5,0	6,0
2	702 023 ... 965 060	36	> 6,0	7,0
2	702 023 ... 965 070	36	> 7,0	8,0
2	702 023 ... 965 080	36	> 8,0	9,0
3	703 023 ... 965 040	42	> 4,0	5,0
3	703 023 ... 965 050	42	> 5,0	6,0
3	703 023 ... 965 060	42	> 6,0	7,0
3	703 023 ... 965 070	42	> 7,0	8,0
3	703 023 ... 965 080	42	> 8,0	9,0
3	703 023 ... 965 090	42	> 9,0	10,0
3	703 023 ... 965 100	42	> 10,0	11,0
3	703 023 ... 965 110	42	> 11,0	12,0

Color Code	Color	RAL-Nr. (similar)
202	red	3020
203	white	9010
204	yellow	1016
205	green	6029
206	blue	5002
207	grey	7005
208	black	9005

Because of different raw materials the colors may slightly differ from RAL numbers.

Temperature range

Silicone -50°C up to +200°C
Short-term up to +230°C
autoclavable

PUR Cable Bend Relief

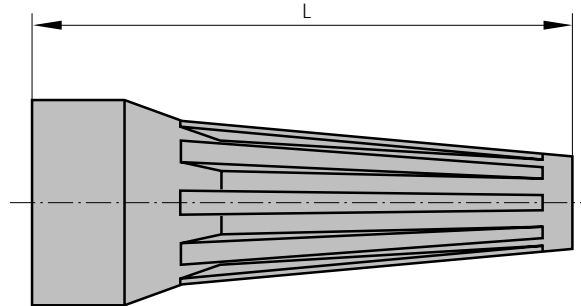

* = In ... please indicate color code

Size	Part Number*	Dim. L	Cable O.D.	
			min.	max.
0	700 022 ... 960 020	27	> 2,0	2,5
0	700 022 ... 960 025	27	> 2,5	3,0
0	700 022 ... 960 030	27	> 3,0	3,5
0	700 022 ... 960 035	27	> 3,5	4,0
0	700 022 ... 960 040	27	> 4,0	4,5
0	700 022 ... 960 045	27	> 4,5	5,0
1	701 022 ... 960 025	30	> 2,5	3,0
1	701 022 ... 960 030	30	> 3,0	3,5
1	701 022 ... 960 035	30	> 3,5	4,0
1	701 022 ... 960 040	30	> 4,0	5,0
1	701 022 ... 960 050	30	> 5,0	6,0
1	701 022 ... 960 060	30	> 6,0	6,5
1	701 022 ... 960 070	30	> 6,5	7,5
1,5	715 022 208 960 040	36	> 4,0	5,0
1,5	715 022 208 960 060	36	> 6,0	5,0
2	702 022 ... 960 030	36	> 3,0	3,5
2	702 022 ... 960 035	36	> 3,5	4,0
2	702 022 ... 960 040	36	> 4,0	5,0
2	702 022 ... 960 050	36	> 5,0	6,0
2	702 022 ... 960 060	36	> 6,0	7,0
2	702 022 ... 960 070	36	> 7,0	8,0
2	702 022 ... 960 080	36	> 8,0	9,0
3	703 022 ... 960 040	42	> 4,0	5,0
3	703 022 ... 960 050	42	> 5,0	6,0
3	703 022 ... 960 060	42	> 6,0	7,0
3	703 022 ... 960 070	42	> 7,0	8,0
3	703 022 ... 960 080	42	> 8,0	9,0
3	703 022 ... 960 090	42	> 9,0	10,0
3	703 022 ... 960 100	42	> 10,0	11,0
3	703 022 ... 960 110	42	> 11,0	12,0

Color Code	Color	RAL-Nr. (similar)
202	red	3020
203	white	9010
204	yellow	1016
205	green	6029
206	blue	5002
207	grey	7005
208	black	9005
209	orange	2004
210	violet	4005
212	brown	8016
215	light green	6018
216	light blue	5012

Because of different raw materials the colors may slightly differ from RAL numbers.

Temperature range
 PUR -40 °C up to +80 °C
 Short-term up to +120 °C

Locking Washers

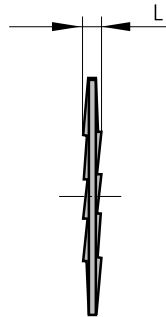
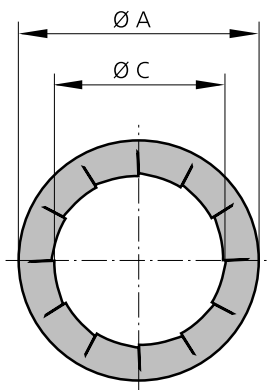

Mounting example:

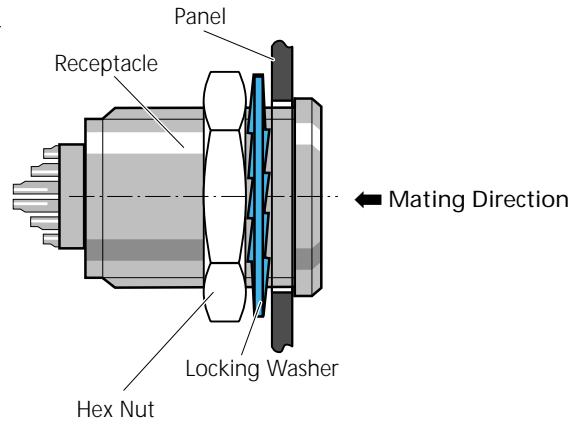

Nickel-plated surface

Size	Part number	Dimensions in mm		
		A	C	L*
M9	945 000 001 000 046	12,5	9,1	0,6
M12	945 000 001 000 047	15,8	12,2	0,6
M14	945 000 001 000 070	19,5	14,2	0,6
M15	945 000 001 000 048	19,5	15,1	0,6
M18	945 000 001 000 049	25,0	18,1	0,8
M25	945 000 001 000 086	32,0	25,2	0,8

*) Measurement under pressure

Solder Lugs for Series L and B

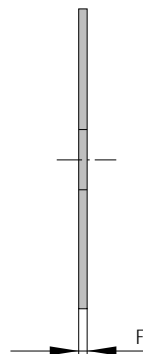
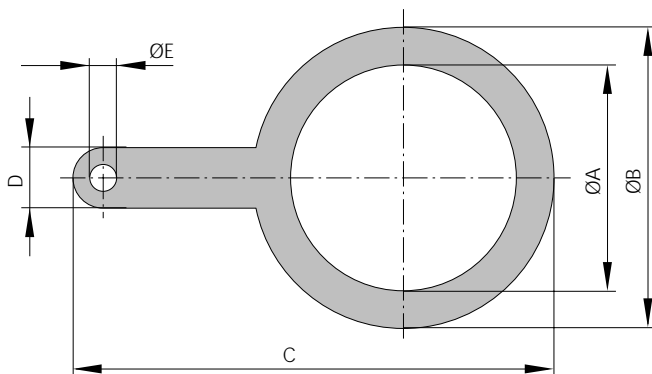

Mounting example:

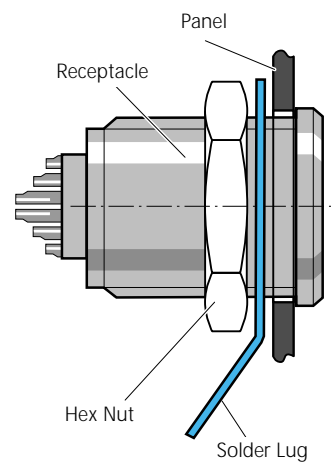

Silver-plated surface

Thread	Part number	Dimensions in mm					
		A	B	C	D	E	F
M9	700 140 246 301 000	9,7	13,2	21,6	4	1,6	0,5
M12	701 140 246 301 000	12,2	17,0	27,5	4	1,6	0,5
M14	715 140 246 301 000	14,05	18,0	27,0	4	2,0	0,5
M15	702 140 246 301 000	15,2	20,0	32,0	4	1,6	0,5
M16	721 140 246 301 000	16,2	20,0	32,0	4	1,6	0,5
M18	703 140 246 301 000	18,2	25,0	39,0	4	1,6	0,5
M25	704 140 246 301 000	25,6	35,0	51,0	5	2,1	0,6

Distance Ring for Wall Thickness Adjustment for style 2

(see page 21)

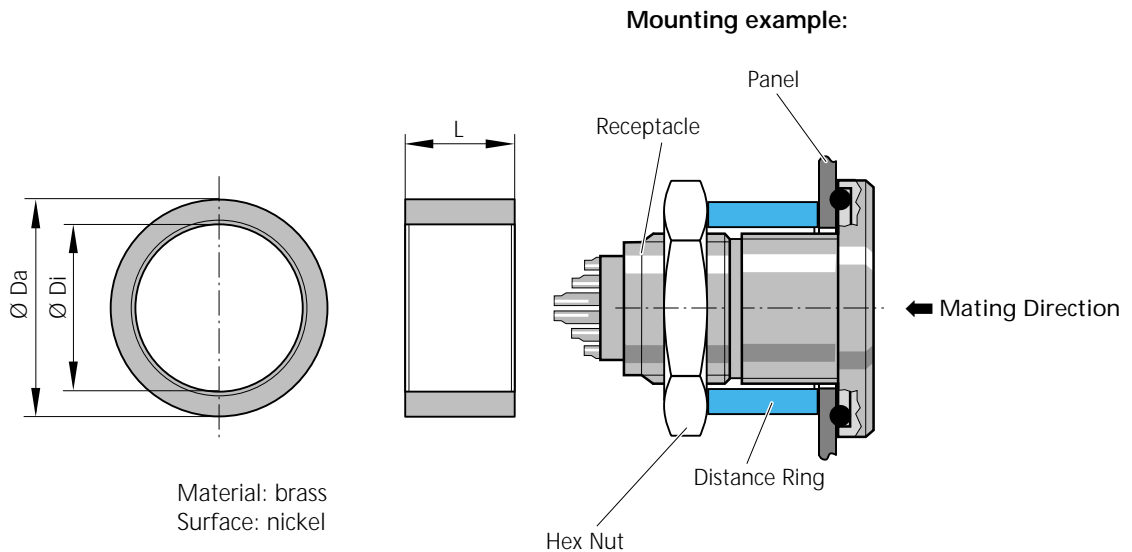

*: Wall Thickness: 0.5 mm - 6 mm
 **: Wall Thickness: 6 mm - 16 mm

Part number	Size	Da	Di	L
700 123 102 304 000	0	13	10,3	7
701 123 102 304 000*	1	17	14,3	12
701 123 102 304 001**	1	17	14,3	6
702 123 102 304 000	2	21	16,3	8

Backnut for Silicone-Cable Bend Relief

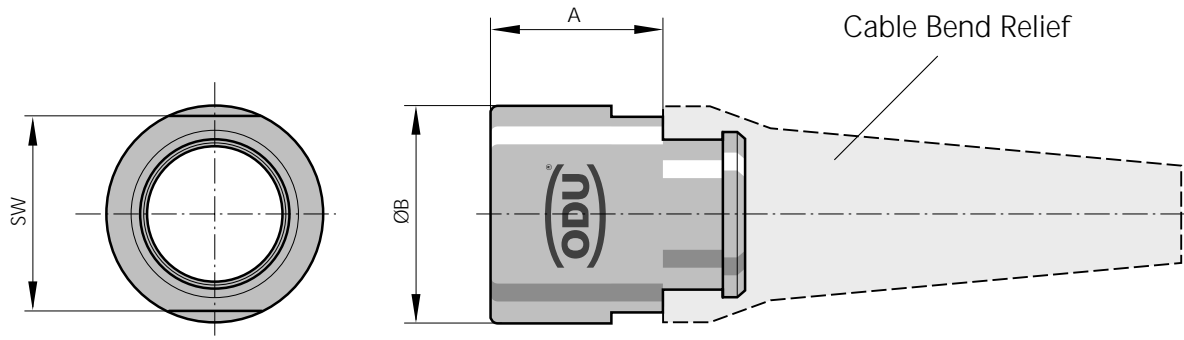

* = In .. please indicate surface finish:
 15 = Cu-alloy / matt chromate
 11 = Cu-alloy / black chromate
 04 = Cu-alloy / nickel

Size	Part number	Dimensions in mm		
		A	ØB	SW
0	700 022 117 3.. 002	8,0	8,9	7
1	701 022 117 3.. 002	10,0	11,2	10
2	702 022 117 3.. 002	11,5	13,9	13
3	703 022 117 3.. 002	11,5	16,9	15

Backnut for PUR-Cable Bend Relief

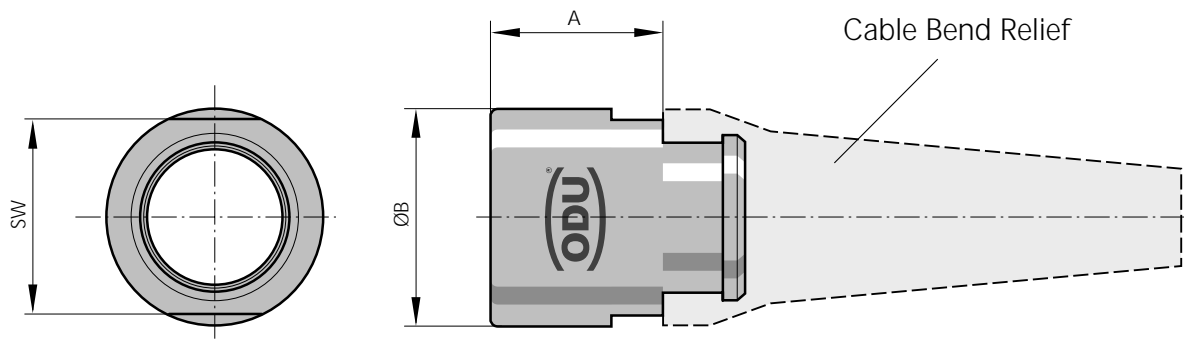

* = In .. please indicate surface finish:
 15 = Cu-alloy / matt chromate
 11 = Cu-alloy / black chromate
 04 = Cu-alloy / nickel

Size	Part number	Dimensions in mm		
		A	ØB	SW
0	700 022 117 3.. 000	8,0	9,0	7
1	701 022 117 3.. 000	10,0	11,0	10
1,5	715 022 117 3.. 000	10,3	12,9	12
2	702 022 117 3.. 001	11,5	13,9	13
3	703 022 117 3.. 001	11,5	16,9	15



Tools



Crimping Tongs and Assembling Tools for Turned Contacts

1. The 037 and 038 Tongs

These both 8-point-crimptongs are new in the catalogue. They will be the standard version in the future.

The 037 Tong

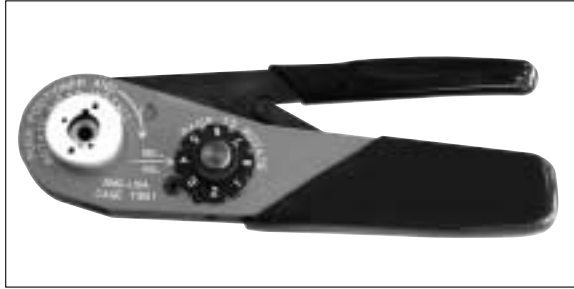

Order number: 080.000.037.000.000
Suitable for our Crimp Contacts with diameter **0,7 – 0,9 mm**.

The 038 Tong

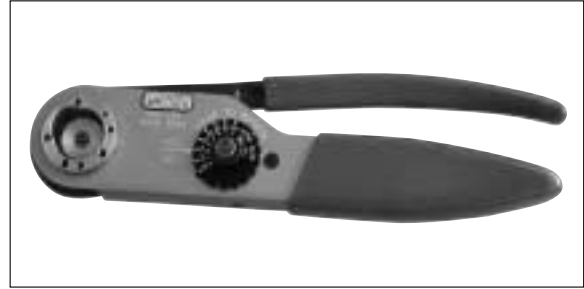

Order number: 080.000.038.000.000
Suitable for our Crimp Contacts with diameter **1,3 mm**.

These both tongs will replace in the early future our 014 tong below. The advantages of these tongs are the easy handling and of course the very good price. All order informations for the equipment of these tongs you can find on page 57.

2. The 014 Tong

This is the precursor version of the above shown tongs. Also here is a 8-point-crimp the result.



Order number: 080.000.014.000.000

Suitable for all available diameters of our ODU MINI-SNAP Crimp Contacts. All order informations for the equipment of these tongs you can find on page 58

3. The 032 Tong

This 032 Tong is a pneumatic 8-point-crimptool. Please contact our Sales Team for Datasheets about this tong

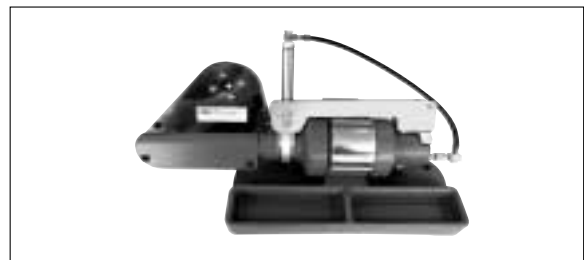

Assembly Jig for the assembling of our Crimp Contacts into the insulation body (see page 61)



Size	Part number
0	700 098 004 300 000
1	701 098 004 300 000
1,5	715 098 004 300 000
2	702 098 004 300 000
3	703 098 004 300 000

Crimping and Assembly Tools for Crimp Contacts (037 and 038)

Position	Size	AWG	mm ²	Adjustment 037 Crimptool 080.000.037.000.000	Adjustment 038 Crimptool 080.000.038.000.000	Positionierer		Insertion Tool
						Socket	Pin	
4	0	24/26 22	0.25/0.15 0.38	4 4	- -	081 700 001 748 037	081 700 001 848 037	085 180 676 000 000
5	0	24/26 22	0.25/0.15 0.38	4 4	- -	081 700 004 748 037	081 700 004 848 037	085 180 676 000 000
3	1	18	1.00/0.75	-	5	081 701 001 744 038	081 701 001 844 038	085 180 955 000 000
4	1	24/26 20/22	0.25/0.15 0.50/0.38	4 7	- -	081 701 001 749 037	081 701 001 849 037	085 180 689 000 000
5	1	24/26 20/22	0.25/0.15 0.50/0.38	4 7	- -	081 701 001 749 037	081 701 001 849 037	085 180 689 000 000
6	1	24/26 22	0.25/0.15 0.38	4 4	- -	081 701 002 748 037	081 701 002 848 037	085 180 676 000 000
7	1	24/26 22	0.25/0.15 0.38	4 4	- -	081 701 002 748 037	081 701 002 848 037	085 180 676 000 000
10	1,5	24/26 22	0.25/0.15 0.38	4 4	- -	081 701 001 748 037	081 701 001 848 037	085 180 677 000 000
12	1,5	24/26 22	0.25/0.15 0.38	4 4	- -	081 701 001 748 037	081 701 001 848 037	085 180 677 000 000
5	2	18	1.0	-	5	081 702 001 744 038	081 702 001 844 038	085 180 955 000 000
6	2	24/28 20/22	0.25/0.08 0.50/0.38	4 7	- -	081 702 001 744 037	081 702 001 849 038	085 180 689 000 000
11	2	24/28 20/22	0.25/0.08 0.50/0.38	4 7	- -	081 702 001 749 037	081 702 001 849 037	085 180 689 000 000
16	2	24/26 22	0.25/0.15 0.38	4 4	- -	081 702 002 748 037	081 702 002 848 037	085 180 677 000 000
19	2	24/26 22	0.25/0.15 0.38	4 4	- -	081 702 002 748 037	081 702 002 848 037	085 180 677 000 000
15	3	24/28 20/22	0.25/0.08 0.50/0.38	4 7	- -	081 702 001 749 037	081 702 001 849 037	085 180 689 000 000
24	3	24/26 22	0.25/0.15 0.38	4 4	- -	081 703 003 748 037	081 702 002 848 037	085 180 677 000 000
27	3	24/26 22	0.25/0.15 0.38	4 4	- -	081 703 003 748 037	081 702 002 848 037	085 180 677 000 000

Order example for the tongs type 037 and 038:

Assumed Connector: S12F1C-T06PJH0-7500

In this size 2 connector is a 6-way Pin Insert used.

The contact diameter is 0,9 mm.
The cable cross section is AWG 20/22

Therefore you have to order following tools:

080.000.037.000.000 Crimp Tong 037 (Adjustment 7)
081.702.001.849.038 Positionier for Pin Contacts
085.180.689.000.000 Insertion tool
702.098.004.300.000 Assembly Jig (see page 56)

You can find all informations about adjustment and using of this tools on the page 59 to 61.

Crimping and Assembly Tools for Crimp Contacts (014)

Position	Size	AWG	mm ²	Adjustment Crimp Tool 080.000.014.000.000	Positionier for Socket / Pin	Gauge pin		Insertion Tool
						min.	max.	
4	0	24/26 22	0.25/0.15 0.38	> 0.65 < 0.70 > 0.65 < 0.70	021 345 184 300 000	080 000 014 000 065	080 000 014 000 070	085 180 676 000 000
5	0	24/26 22	0.25/0.15 0.38	> 0.65 < 0.70 > 0.65 < 0.70	021 345 186 300 000	080 000 014 000 065	080 000 014 000 070	085 180 676 000 000
3	1	18	1.0/0.75	> 1.10 < 1.15	021 345 189 300 000	080 000 014 000 110	080 000 014 000 115	085 180 955 000 000
4	1	24/26 20/22	0.25/0.15 0.50/0.38	> 0.65 < 0.70 > 0.90 < 0.95	021 345 192 300 000	080 000 014 000 065 080 000 014 000 090	080 000 014 000 070 080 000 014 000 095	085 180 689 000 000
5	1	24/26 22/22	0.25/0.15 0.50/0.38	> 0.65 < 0.70 > 0.90 < 0.95	021 345 192 300 000	080 000 014 000 065 080 000 014 000 090	080 000 014 000 070 080 000 014 000 095	085 180 689 000 000
6	1	24/26 22	0.25/0.15 0.38	> 0.65 < 0.70 > 0.65 < 0.70	021 345 175 300 000	080 000 014 000 065	080 000 014 000 070	085 180 676 000 000
7	1	24/26 22	0.25/0.15 0.38	> 0.65 < 0.70 > 0.65 < 0.70	021 345 175 300 000	080 000 014 000 065	080 000 014 000 070	085 180 676 000 000
10	1.5	24/26 22	0.25/0.15 0.38	> 0.65 < 0.70 > 0.65 < 0.70	021 345 187 300 000	080 000 014 000 065	080 000 014 000 070	085 182 677 000 000
12	1.5	24/26 22	0.25/0.15 0.38	> 0.65 < 0.70 > 0.65 < 0.70	021 345 187 300 000	080 000 014 000 065	080 000 014 000 070	085 182 677 000 000
5	2	18	1.0	> 1.10 < 1.15	021 345 188 300 000	080 000 014 000 110	080 000 014 000 115	085 180 955 000 000
6	2	24/28 20/22	0.25/0.08 0.50/0.38	> 0.65 < 0.70 > 0.90 < 0.95	021 345 174 300 000	080 000 014 000 065 080 000 014 000 090	080 000 014 000 070 080 000 014 000 095	085 180 689 000 000
11	2	24/28 22/22	0.25/0.15 0.50/0.38	> 0.65 < 0.70 > 0.90 < 0.95	021 345 174 300 000	080 000 014 000 065 080 000 014 000 090	080 000 014 000 070 080 000 014 000 095	085 180 689 000 000
16	2	24/26 22	0.25/0.15 0.38	> 0.65 < 0.70 > 0.65 < 0.70	021 345 190 300 000	080 000 014 000 065	080 000 014 000 070	085 180 677 000 000
19	2	24/26 22	0.25/0.15 0.38	> 0.65 < 0.70 > 0.65 < 0.70	021 345 190 300 000	080 000 014 000 065	080 000 014 000 070	085 180 677 000 000
15	3	24/28 20/22	0.38 1.0	> 0.65 < 0.70 > 0.90 < 0.95	021 345 172 300 000	080 000 014 000 065 080 000 014 000 090	080 000 014 000 070 080 000 014 000 095	085 180 689 000 000
24	3	24/26 22	0.25/0.15 0.38	> 0.65 < 0.70 > 0.65 < 0.70	021 345 190 300 000	080 000 014 000 065	080 000 014 000 070	085 180 677 000 000
27	3	24/26 22	0.25/0.15 0.38	> 0.65 < 0.70 > 0.65 < 0.70	021 345 190 300 000	080 000 014 000 065	080 000 014 000 070	085 180 677 000 000

Order example for the tong type 014:

Assumed Connector: S12F1C-T06PJH0-7500

In this size 2 connector is a 6-way Pin Insert used.

The contact diameter is 0,9 mm.

The cable cross section is AWG 20/22

Therefore you have to order following tools:

080.000.014.000.000 Crimp Tong Type 014
021.345.174.300.000 Positionier for Pin Contacts
080.000.014.000.090 Gauge Pin (smallest diameter)
080.000.014.000.095 Gauge Pin (biggest diameter)
085.180.689.000.000 Insertion Tool

You can find all informations about adjustment and using of this tools on the page 59 to 61.

Adjustment of the Crimp Tongs 080.000.037.000.000 and 080.000.038.000.000 (see page 56)



1. Fasten the Positionier on the Crimp Tong



Please fasten the Positionier under consideration of the guiding into the tong



037: Therby push the positionier down and turn it right at the same time.
038: You don't have to do this with this tong.



037: To fix the positionier in this position, you have to use the attached safety pin.
038: Here you have to fix the positionier with some attached allen screw and the suitable spanner.

2. Adjust of the Crimp Tong for the cable cross section



Please turn the adjustment wheel onto the right position. If the adjustment is done, so please fix the wheel with the attached safety pin.

Now the tong is ready adjusted. You can start with the crimp process

Adjustment of the Crimp Tong 080.000.014.000.000

(see page 56)

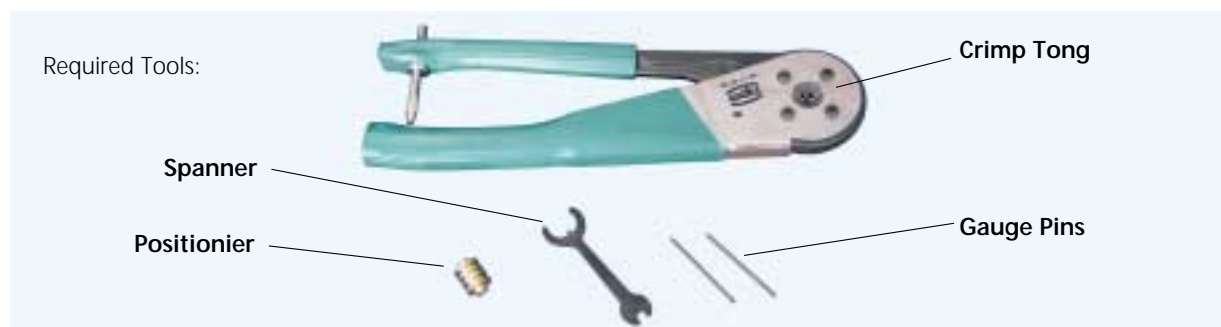

1. Fasten the Positionier on the Crimp Tong



Please insert the positionier into the tong.

Attention: The positionier is labeled with a "S" (=Socket) on the one, and with a "P" (=Pin) on the other side. So if your contact is a socket, so please insert the S-face into the tong. If your contact is a pin, so please insert the P-face into the tong.



Now you have to insure the positionier with a clamp. Fix the clamp with the screw driver.

2. Adjustment of the Crimp Tong for the cable cross section



At first you have to loose the securing nut of the setscrew. Therefore please use the attached spanner.



With turning on the setscrew you can adjust the cable cross section. Therefore you have to close the crimp tong completely.



With the gauge pins you have to prove the cable cross section. If the smaller gauge pin fit through the hole in the crimp dies, and the bigger one not, the tong is ready adjusted. Please insure the adjustment with the securing nut.

Now you can start with the crimp process.

ODU MINI-SNAP Crimp Instruction

Suitable for the tongs 080.000.014.000.000, 080.000.037.000.000, 080.000.038.000.000,



1. Crimp the Wire into the Contact.



Insert the contact in the tong. Put the stripped wire into the termination funnel (stripping length see page 67).



Close the tong completely and the crimp is done. Now you can pull out the crimped contact.

2. Press the crimped Contact into the insulation body.



Put the contacts under consideration of the pos. numbering into the insulation body. Therefore please use the assembly jig.



With the corresponding insertion tool (order information see page 56 - 58) you can press in the contacts into the insulation body until it snap in.



Now the assembled insert is ready.

Spanner Wrench

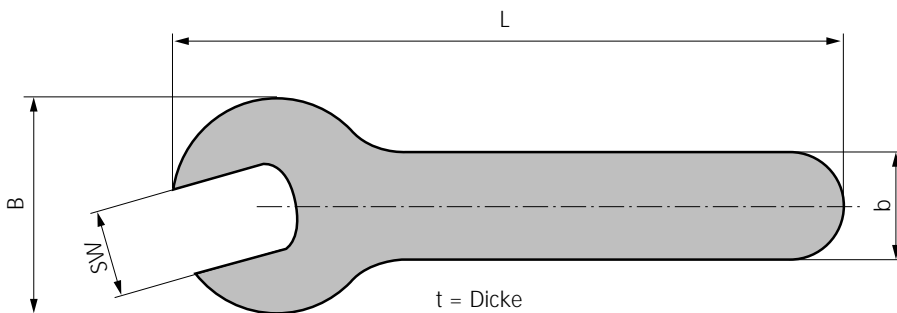

Order No.	SW	t	B	L	b
598.700.001.016.000	5	1,5	18,5	92	8
598.700.001.015.000	5,5	1,5	18,5	92	8
598.700.001.021.000	6	2	18,5	92	8
598.700.001.011.000	7	2	18,5	92	8
598.700.001.001.000	8	2	18,5	92	8
598.700.001.022.000	9	2	21,5	102	9
598.700.001.002.000	10	2	21,5	102	9
598.700.001.012.000	11	2	24,5	115	10
598.700.001.003.000	12	2,5	24,5	115	10
598.700.001.017.000	12,5	4	24,5	115	10
598.700.001.004.000	13	2,5	30,5	98	16,5
598.700.001.005.000	14	2,5	30,5	98	16,5
598.700.001.006.000	15	3	35,5	145	15
598.700.001.007.000	16	3	35,5	145	15
598.700.001.008.000	17	3	35,5	145	15
598.700.001.023.000	18	3	42	172	16
598.700.001.013.000	19	3	42	172	16
598.700.001.009.000	20	3	42	172	16
598.700.001.018.000	21	3	42	172	16
598.700.001.010.000	22	3	47	119	23,5
598.700.001.014.000	24	3	47	119	23,5
598.700.001.019.000	30	3	50	150	25
598.700.001.020.000	31	3	50	150	25

Nutdriver for Slotted Mounting

suitable for style 8 , C , Q

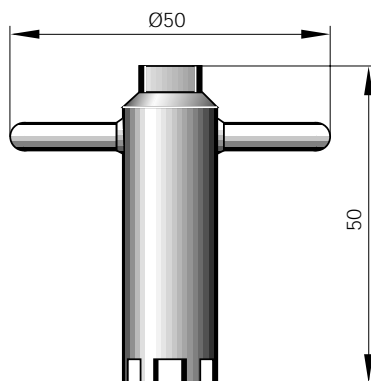

Nutdriver	Thread
700 098 002 000 000	M 9x0,5
700 098 001 000 000	M 10x0,5
700 098 001 000 000	M 12x1
701 098 002 000 000	M 14x1
701 098 001 000 000	M 15x1
702 098 001 000 000	M 16x1
702 098 001 000 000	M 18x1
703 098 001 000 000	M 20x1

Assembly Instructions



Assembly Instruction

For unsealed connectors (IP 50)

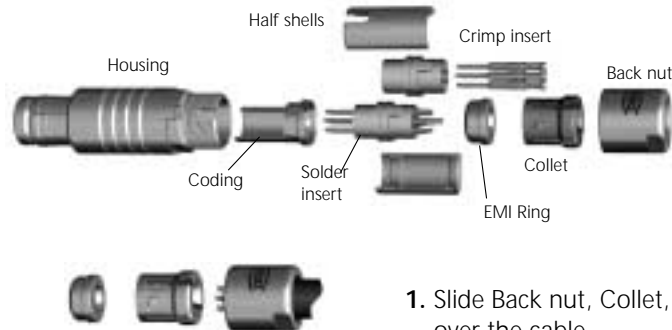

1. Slide Back nut, Collet, and EMI-Ring over the cable.

Crimp termination

Detail information see page 56 - 61



Part number see page 56

2. Strip cable and wire.
3. Fit wire into the contact barrel and crimp.



Part number see page 57 - 58

4. insert contacts into insulator, use the insertion tool to push them in.



Half shells

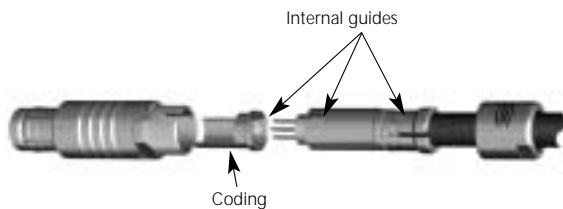

Coding



A

Solder termination



2. Strip cable and wire.
3. Pre-tinning of strands recommended.



Solder iron

4. Solder each wire to the corresponding contact.

5. Bend cable shield outwards.

6. Slide the EMI-ring against the sleeve and clamp the shield against it.

7. Now you can put the coding and the assembled cable into the plug housing.

8. Screw back nut on the plug and fasten cable in the housing.
Hold against with flat spanner at flat A* (**Torque see page 67**).
Now the plug is assembled.

* ODU-Spanner-Wrench: see page 62

Assembly Instruction

For sealed connectors (IP 68)

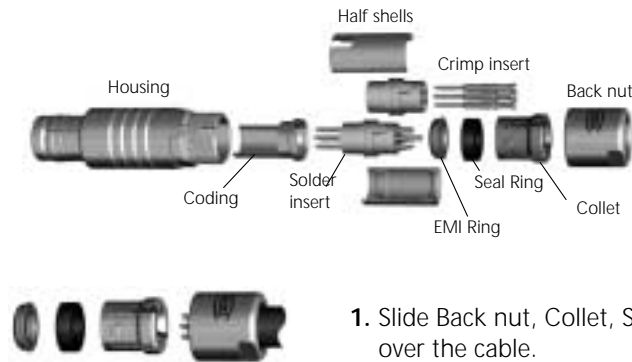

1. Slide Back nut, Collet, Seal Ring and EMI-Ring over the cable.

Crimp termination

Detail information see page 56 - 61



Part number see page 56

2. Strip cable and wire.
3. Fit wire into the contact barrel and crimp.



Part number see page 57 - 58

4. insert contacts into insulator, use the insertion tool to push them in.



Half shells

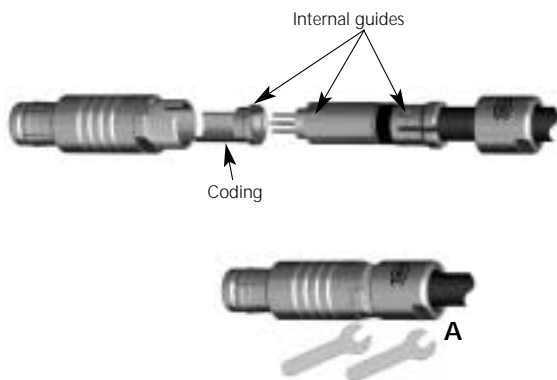

Coding

A

Solder termination



2. Strip cable and wire.
3. Pre-tinning of strands recommended.



Solder iron

4. Solder each wire to the corresponding contact.

5. Bend cable shield outwards.

6. Slide the EMI-ring against the sleeve and clamp the shield against it.

7. Now you can put the coding and the assembled cable into the plug housing.

8. Screw back nut on the plug and fasten cable in the housing. Hold against with flat spanner at flat A* (**Torque see page 67**). Now the plug is assembled.

* ODU-Spanner-Wrench: see page 62

Watertight connectors require a grommet seal designed for the intended cable. We require either the exact specification or a sample of the cable.

Assembly Instruction

for unsealed right-angled plugs (IP 50)

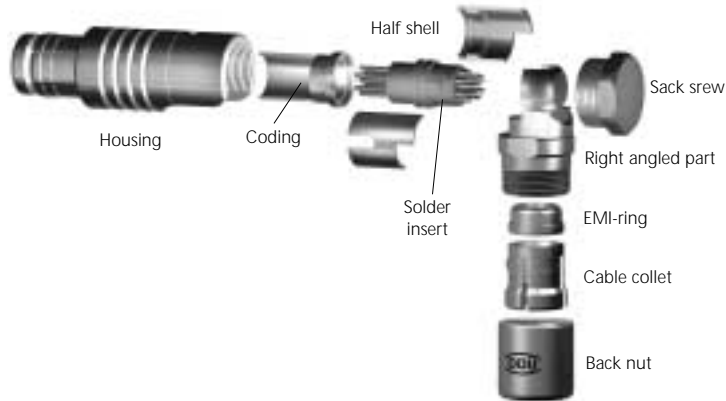

1. Slide back nut, collet nut, EMI-ring and right-angled-part over the cable.



2. Strip cable and wire.
3. Pre-tinning of strands recommended.



4. Solder each wire to the corresponding contact (Crimp version see straight connector on page 64).



5. Pull cable back, bend cable shield outwards, place half shells over insulator.



6. Slide collet nut and EMI-ring against the right-angled-part and clamp shield between EMI-ring and right-angled-part. Install back nut.

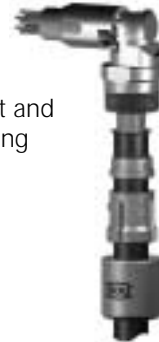

7. Now you can put the coding and the assembled cable into the plug housing.

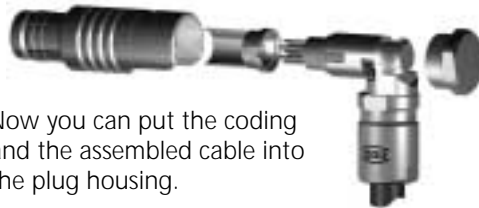

8. Mount sack screw on the plug and fasten cable in the housing. Hold against with flat spanner at flat A* (**Torque see page 67**). Now the plug is assembled.



* ODU-Spanner-Wrench: see page 62

Torque for back-nuts

Torque for styles

- Straight plug S1; S2; S3; S4
- Right-angled-plug W1; W2
- Break-apart-plug A5; A6; A7; A8
- In-line-receptacle K1; K2; K3; K4
- Receptacle G6; G7

Style	0	1	1,5	2	3
Torque	0,6 Nm	1,0 Nm	1,5 Nm	2,0 Nm	3,5 Nm

1 Nm = 8,85 inch-pounds

Cable preparation:

The following table provides recommended guidelines for cable preparation:

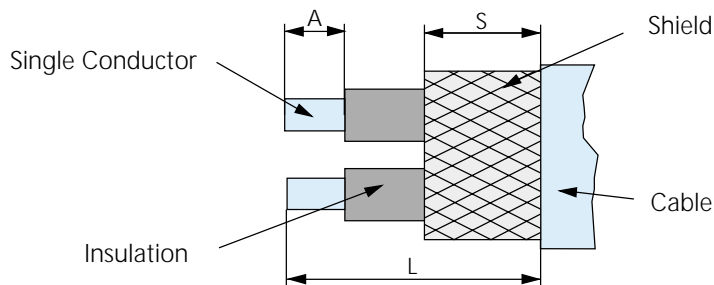

A = Stripping length single conductor
 L = Stripping length cable jacket
 S = Stripping length braided shield

Size	Contact Ø	Solder Termination			Crimp Termination		
		L	A	S	L	A	S
Size 0	0.5	6	2	2,5	-	-	-
	0.7	6	2,5	2,5	6	3	2,5
	0.9	6	2,5	2,5	6	3	2,5
Size 1	0.5	9	2	2,5	-	-	-
	0.7	9	2,5	2,5	13	4	2,5
	0.9	9	2,5	2,5	13	4	2,5
Size 1,5	1.3	9	3	2,5	13	4	2,5
	0.5	12	2	2,5	-	-	-
	0.7	12	2,5	2,5	16	4	2,5
Size 2	0.7	11	2,5	2,5	15	4	2,5
	0.9	11	2,5	2,5	15	4	2,5
	1.3	11	2	2,5	15	4	2,5
Size 3	0.7	14	2,5	2,5	18	4	2,5
	0.9	14	2,5	2,5	18	4	2,5
	1.3	14	3	2,5	18	4	2,5

All dimensions in mm Tolerance: + 10 %

Exceptions are noted on special instructions.
 Right-angle plugs have special instructions.

Standard Packing

- Plug

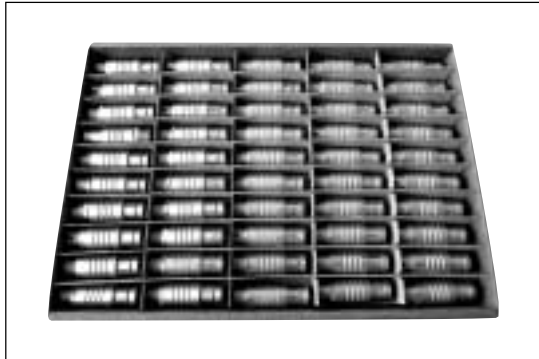

Housing

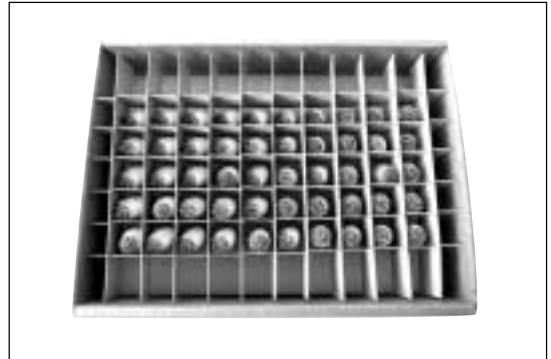

Contact Inserts



Back Nut



Accessories (Collet nuts, Cable Bend Reliefs etc.)

- Receptacles



Receptacles with Solder- Crimp- and PCB-Contacts

There are different packings possible, due to different sizes, quantities, styles ect.

Technical Information

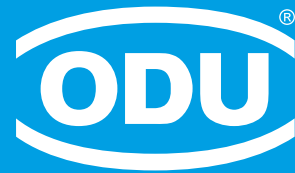
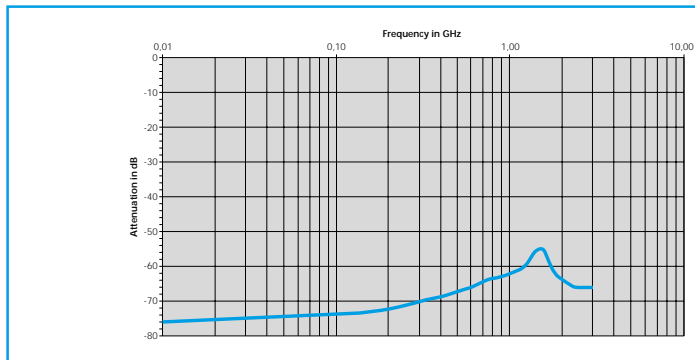

INDEX:

International Protection (IP) Classes (DIN EN 60 529)	70
Watertightness of the ODU MINI-SNAP	71
Insulation Groups / Nominal Voltage / Test Voltage	72
Normal Voltage acc. to SAE AS 13441-method 3001.1	73
Current Load - Turned Contacts	74
Termination Styles	75
Conversion Table AWG to Metric	76
Housing Materials / Surfaces	77
Electromagnetic Compatibility (EMC)	78
ODU MINI-SNAP in Signal Bus Applications	79
Autoclaving of ODU MINI-SNAP	80
Quality Management	81
Tests acc. to MIL	82
Technical Terms & Definitions	83



International Protection (IP) Classes DIN EN 60 529 (respectively IEC 529 / VDE 0470 T1)

The housing and the locking system of the ODU MINI-SNAP protect the contacts against outside mechanical influence, such as impact shocks, impurities, dust, unintended contact and penetration of moisture, water or other liquids (coolants, oils, etc.).

Protection classification is indicated with the letters **IP** and two numbers.

IP: International Protection

All IP 68 submersible ODU MINI-SNAP Connectors are rated to 2 m water depth (0,2 bar) for 24 hours in accordance with DIN EN 60529.

A watertight plug requires a cable grommet in the collet. The grommet has to fit tightly over the cable.

The cable jacket must be smooth, cylindrical and free of grooves.

The plug should be potted for watertightness in unmated condition.

(Higher requirements for Watertightness on request)

Code letters (International Protection)		First Index Figure (Foreign bodies protection)	Second Index Figure (Water protection)	
IP		6	8	
Index	Degree of protection	Index	Degree of protection	
0	No protection against accidental contact, no protection against intrusion of solid foreign bodies	0	No protection against water	
1	Protection against contact with any large area by hand and against large solid foreign bodies with Ø > 50 mm	1	Protection against vertical water drips	
2	Protection against contact with the fingers, protection against large solid foreign bodies with Ø > 50 mm	2	Protection against water drips (up to a 15° angle)	
3	Protection against tools, wires or similar objects with Ø > 2.5 mm. Protection against small foreign solid bodies with Ø > 2,5 mm	3	Protection against diagonal water drips (up to a 60° angle)	
4	As 3 however Ø > 1 mm	4	Protection against splashed water from all directions	
5	Full protection against contact. Protection against interior detrimental dust deposition.	5	Protection against water spray from all directions	
6	Total protection against contact. Protection against intrusion of dust	6	Protection against temporary flooding	
		7	Protection against temporary immersion	
		8	Protection against water pressure	

In accordance with DIN VDE 0470, DIN EN 60 529, IEC 529
Source: ZVEI = German Association of the Electrotechnical and Electronic Industry e.V.

Watertightness of the ODU MINI-SNAP

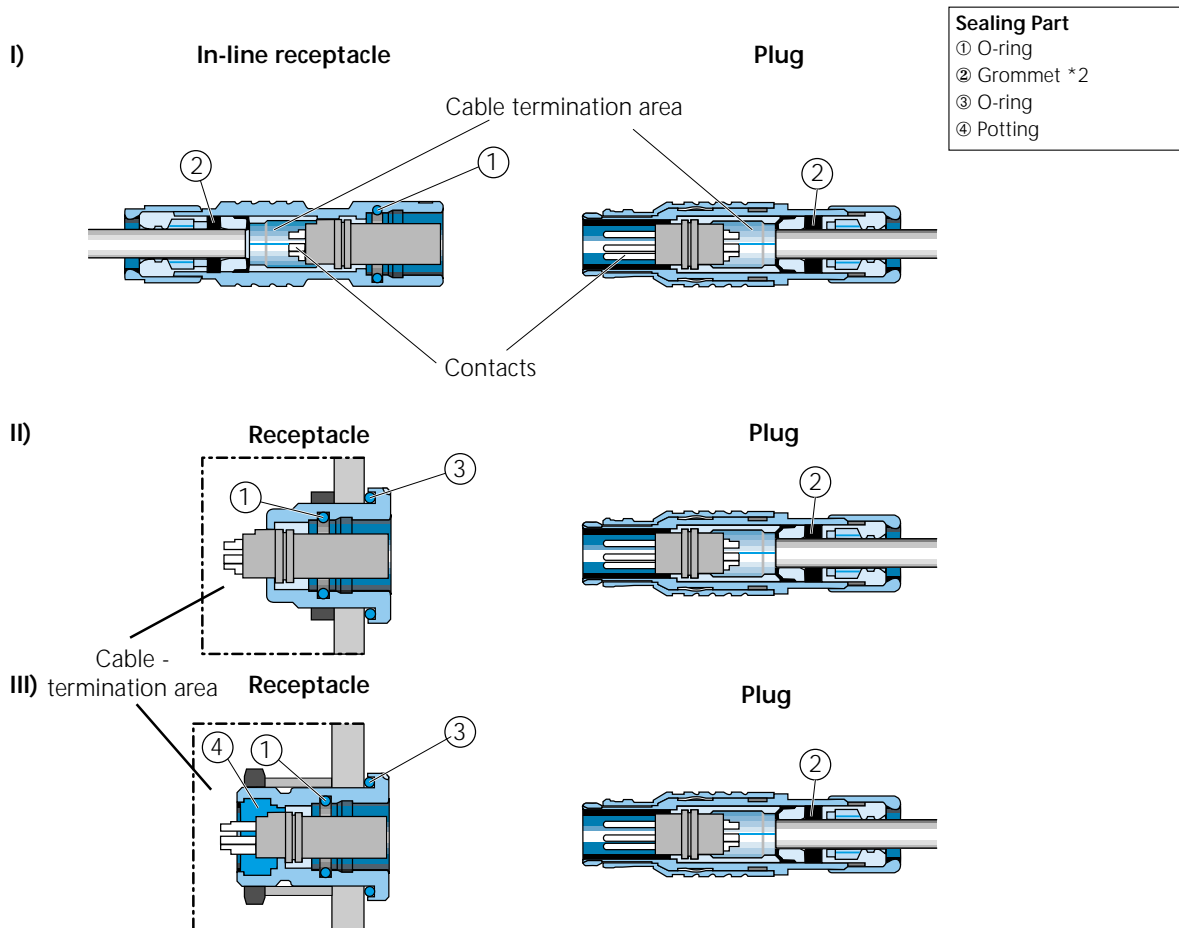

Protection against Water through following seals: *1

		mated	unmated
I	Cable – Cable termination area	Yes ① + ②	No
II	Device – Cable termination area	Yes ① + ③ + ②	No
III	Device – Cable termination area	Yes ① + ③ + ②	Yes ③ + ④

*1 Contacts: in mated condition the contacts are protected (in cases I, II, III). In unmated condition the contacts can be protected using a protective cover (see page 47 - 48). The cover must be removed before mating the plug with the receptacle.

*2 The elastic grommet acts as the cable seal. It requires exact knowledge of the cable dimension.
Important factors: Diameter tolerance, roundness, cable design and cable jacket hardness.

Insulation Groups / Nominal Voltage / Test Voltage

Insulation Groups in accordance with DIN VDE 0110 T1/2.79

Groups of connectors based on ambient and operating conditions.

Example :

A connector used in a shop environment falls into Group B. (Laboratory environment would fall into Group A).

Insulation Group A0 :

For low power equipment in climate-controlled and dry rooms with only minimal heat rise when subjected to short circuit conditions.

Insulation Group A :

For equipment operated in climate-controlled and dry rooms.

Insulation Group B :

For equipment operated in living quarters, offices, and other commercial environments. Also for clean machine shops, laboratories, test stands, and medical environments.

Insulation Group C :

Equipment primarily operated in industrial, commercial, and agricultural establishments. Non climate-controlled warehouses, workshops, boiler rooms, and manufacturing floors.

Insulation Group D :

Equipment operated on vehicles subjected to dirt, brake dust, and splash water or snow. Unprotected by housing.

Determination of Nominal Voltage from Test Voltage in accordance with VDE 0627

The following explains how to derive the nominal voltage from the test voltage. (For practical purposes nominal voltage, rated voltage, and reference voltage are the same.)

The operating voltage must be less than the nominal voltage. A clear definition can be found in DIN VDE 0110, page 83.

Example :

The selected connector has a test voltage of 1,000 VAC and will be operated in a clean mechanical shop environment (Insulation Group B)

According the Table 3 below, the connector has a nominal voltage of 150 VDC. (The example shows both printed in **bold**.)

Notice: According to MIL-STD-1344, Method 3001 higher Test Voltages are acceptable (see next page).

Table 3 from DIN VDE 0627

Reference Voltage / Nominal Voltage in Volt		Test Voltage in Volt (AC 50 Hz)				
in Volt (DC)	in Volt (AC)	Insulation Group				
		A0	A	B	C	D
15	12	375	500	750	875	1250
36	30	500	500	750	1000	1500
75	60	500	625	875	1000	1500
150	125	625	750	1000	1250	1750
300	250	750	875	1250	1750	2250
450	380	875	1000	1750	2250	3000
600	500	1000	1250	2000	2750	3500
800	660	1250	1750	2500	3500	4000
900	750	1500	1750	2750	3500	4500
1200	1000	1750	2250	3500	4500	5500

Operating voltage acc. to SAE AS 13441-method 3001.1

The values acc. to SAE AS 13441-method 3001.1 comply with MIL-Std. 1344 – method 3001.

The chart values results are acc. to IEC 60512-2. The inserts have been tested in mated condition and the test voltage was applied to the pin insert.

75% of the measured break-down voltage is the basic for the further calculation. 1/3 of this value is the corresponding operating voltage.

All tests were performed at standard environment conditions (room temperature) and can be applied up to an altitude of 2000 m.

For any deviations one has to consider the reduction factor acc. to the relevant standards.

Test voltage: Break-down voltage x 0,75

Operating voltage: Break-down voltage x 0,75 x 0,33

Caution:

Electrical appliances: for various applications the safety requirements regarding the operating voltage is even more severe!

The relevant data in such cases for the operating voltage are the creepage and clearance distances. For any advise how to chose the proper connector please consult us and indicate the safty standard which your product has to meet.

Current Load - Contacts

Nominal Single Contact Current Load for pin / slotted socket

(Nominal Diameter 0.5 mm - 1.6 mm)

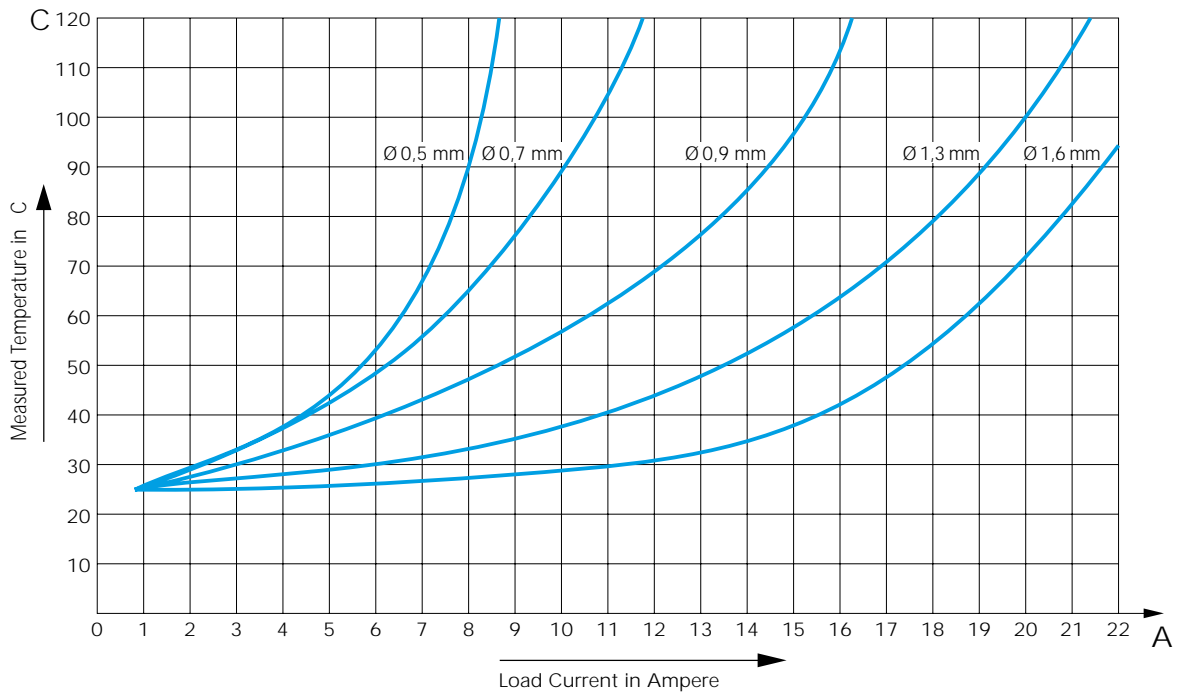

➔ **Upper Maximum Temperature for Standard Contacts:** + 120 °C

Test contact was terminated to largest possible conductor.

Connectors or cables with more than one contact or conductor generate a higher heat than a single contact. Therefore, a **Derating Factor** must be applied. For connectors the Derating Factor is applied according to DIN IEC 60512-3 / VDE 0276-1000. The Derating Factor is used starting with 5 loaded wires.

Derating Factor:

Number of loaded wires	Derating Factor
5	0,75
7	0,65
10	0,55
14	0,50
19	0,45
24	0,40

Termination Styles

Contact blocks (insulation bodies with contacts) are interchangeable between receptacle and plug. As a rule the socket contact blocks are mounted in the part under power.

ODU offers the following contact termination styles:

- Solder
- Crimp
- PCB

Termination Styles for Turned Contacts

Solder Termination:

The contacts come mounted by the factory. The insulation body and the pre-assembled contacts are called a contact block.



Crimp Termination

A single contact is crimped to a single conductor. Subsequently, the crimped contact is pushed into the insulation body. Crimp contacts and insulation bodies are shipped separately.

Crimping creates a reliable, corrosion-free and durable connection between the contact and the conductor.

Crimping causes the crimp barrel of the contact and the conductor material to cold flow. It creates a gas-tight connection between contact and conductor.

The ODU MINI-SNAP generally requires the industry-standard 8-point crimp tool .



Printed Circuit Board (PCB) Termination:

PCB pins are used only for receptacles which are mounted directly to the PCB. The contacts are permanently installed in the insulation body.



Conversion / AWG

AWG = American Wire Gauge

The AWG system describes the cross section of a wire using a gauge number for every 26 % increase in conductor cross section. With larger wire diameters, the AWG gauge numbers decrease; as the wire sizes increase, the AWG gauge numbers decrease.

Most wires are made with **stranded conductors**. Compared to solid conductors stranded wires offer higher durability, higher flexibility and better performance under bending and vibration.

Stranded wires are made from wires with smaller gauge sizes (higher AWG gauge number). The AWG gauge number of the stranded wire is equal to that of a solid conductor of the same size wire. The cross section of the stranded conductor is the sum of cross sections of the single conductors.

For example, a AWG-20 stranded wire of 7 AWG-28 conductors has a cross section of 0.563 mm²; an AWG-20 stranded wire with 19 AWG-32 conductors has a cross section of 0.616 mm².

Conversion Table AWG / mm²

Circular Conductor			
AWG	Diameter		mm ²
	in	mm	
10 (1)	0,102	2,59	5,27
10 (37/26)	1,109	2,75	4,53
12 (1)	0,0808	2,05	3,31
12 (19/25)	0,0895	2,25	3,08
12 (37/28)	0,0858	2,18	2,97
14 (1)	0,0641	1,63	2,08
14 (19/27)	0,0670	1,70	1,94
14 (37/30)	0,0673	1,71	1,87
16 (1)	0,0508	1,29	1,31
16 (19/29)	0,0551	1,40	1,23
18 (1)	0,0403	1,02	0,82
18 (19/30)	0,0480	1,22	0,96
20 (1)	0,032	0,813	0,52
20 (7/28)	0,0366	0,93	0,56
20 (19/32)	0,0384	0,98	0,62
22 (1)	0,0252	0,64	0,324
22 (7/30)	0,0288	0,731	0,354
22 (19/34)	0,0307	0,780	0,382
24 (1)	0,0197	0,50	0,196
24 (7/32)	0,023	0,585	0,227
24 (19/36)	0,0252	0,640	0,240
26 (1)	0,157	0,40	0,122
26 (7/34)	0,0189	0,48	0,140
26 (19/38)	0,0192	0,487	0,15
28 (1)	0,0126	0,32	0,08
28 (7/36)	0,015	0,381	0,089
28 (19/40)	0,0151	0,385	0,095
30 (1)	0,0098	0,250	0,0506
30 (7/38)	0,0115	0,293	0,055
30 (19/42)	0,0123	0,312	0,072
32 (1)	0,0080	0,203	0,032
32 (7/40)	0,0094	0,240	0,035
32 (19/44)	0,0100	0,254	0,044
34 (1)	0,0063	0,160	0,0201
34 (7/42)	0,0083	0,211	0,0266
36 (1)	0,0050	0,127	0,0127
36 (7/44)	0,0064	0,163	0,0161
38 (1)	0,0040	0,100	0,0078
40 (1)	0,0031	0,080	0,0050
42 (1)	0,0028	0,0700	0,0038
44 (1)	0,0021	0,054	0,0023

(Font: Gore & Associates, Pleinfeld)

Housing Materials and Surface Finish

MINI-SNAP housings are made from brass and are nickel-plated with a matt-chromate surface finish (sand-blasted). Nickel-plated or black chromate-finished housings are available on special request.

Inside metal components are made from nickel-plated brass.

	Material	Surface
Component Parts	Designation	Thickness of the film
Housing Back Nut Slotted Nut	→ Cu-alloy	+ 1 µm Cu + 3-6 µm Ni + 0.3-1 µm matt chromate
Collet EMI-Ring Half-Shells Locking Washer Nut Retainer Ring	→ Cu-alloy	→ Ni matt: 6-8 µm
Pin (solder or PCB) Socket (solder or PCB) Pin (crimp) Socket (crimp)	→ Cu-alloy	+ 1.25 µm Ni → + 0.75 µm Au

Insulation Body Material (recognized)

	Norm		Unit	PBT	PTFE 1)	PEEK
Dialectric Strength	DIN 53481	ASTM D-149	KV / mm	27	> 50	19
Operating Temperature	--	--	°C	- 40 / + 140	-100 / + 260	-50 / +250
Flammability rating	UL-94	--	--	V-0	V-0	V-0
Creeping distance acc. to CTI	IEC 60112		(V)	275	600	175

¹⁾ PTFE (Teflon) is only used for Coax- and Triax Connectors

Electromagnetic Compatibility (EMC)

When discussing electromagnetic compatibility (EMC) one should not only consider the device or the circuit, but also include the network and the entire data communication link. This involves all connecting elements such as conductors and connectors. Electromagnetic interference from the outside into the connector can lead to system malfunctioning. The best way to prevent this is by providing a high-quality shield between the cable and the connector. In order to provide reliable EMC data to our customers we engaged the services of a certified test laboratory to investigate the EMC characteristics of the ODU MINI-SNAP. They tested for us Size 00, 0, 1, 2 and 3 MINI-SNAP connectors.

Measurements were conducted using the inductive wire or parallel wire method in accordance with test procedure VG 95214-6-2. In this set-up, the mated connector is connected on one end to a network analyzer and terminated on the other end with a suitable impedance. The inductive wire is then mounted in close proximity along the mated connector pair. The induction wire is a ribbon cable which permits to vary the level of induction by using more or less of the ribbon conductors.

Next, a signal with a frequency range of 10 kHz to 3 GHz is connected to the ribbon cable. The network analyzer is used to measure the amount of signal induced into the connector circuit. The result is shown as the shielding attenuation A_T in dB. It is essential that all leads to the connector are shielded so that no signal can be induced into the circuit at any other place except the connector. The various attenuation values are plotted on a logarithmic scale as attenuation in dB vs. frequency.

An attenuation of better than -55 dB is generally required for reliable connector and system operation. It can be shown that our connectors will meet this requirement in all applications.

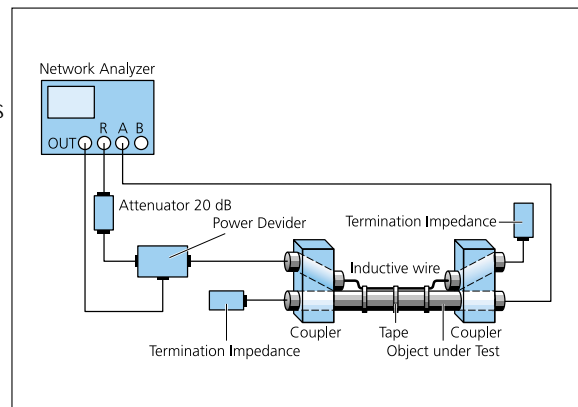

The following diagram is valid for all series and standard sizes.

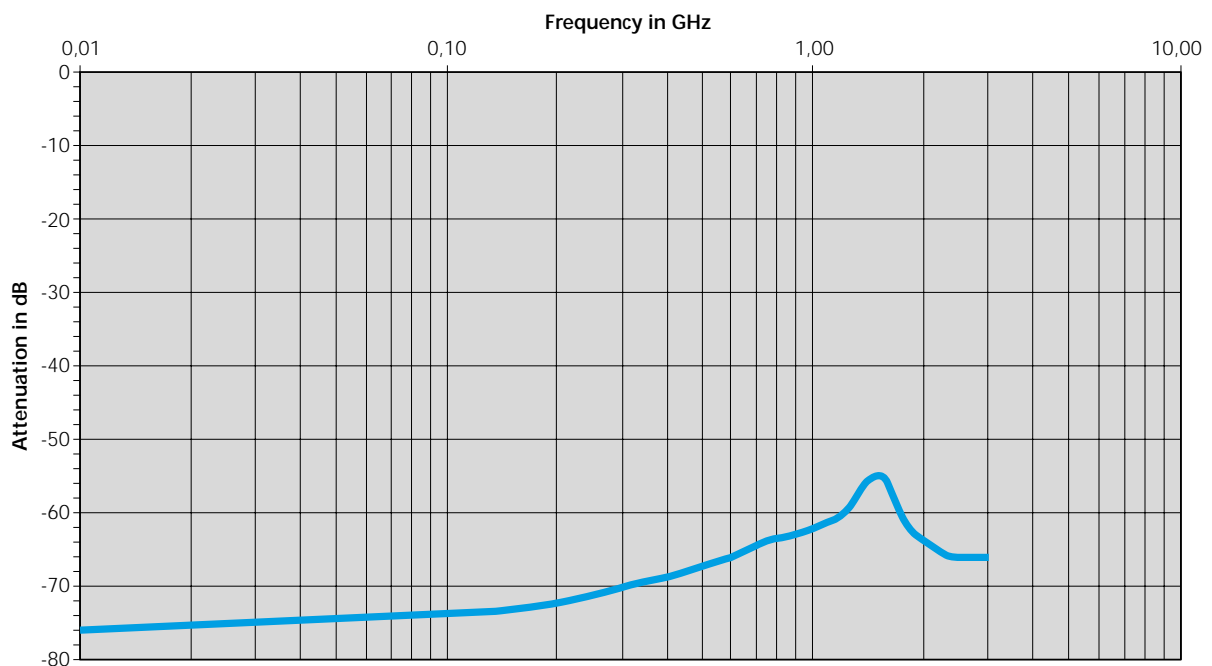

ODU MINI-SNAP in Signal Bus Applications

Most signal bus applications require standard connectors.

However, there may be special situations which could require watertightness, EMV-protection, or high-frequency performance.

Name	Data-rate	Range of application (example)	Standard connect
USB	12 Mbit/s	computer peripherals	4-position, shielded
Profibus	12 Mbit/s	computer peripherals	4 + 2-position shielded
Interbus	0,5 Mbit/s	process-automation	D-Sub 9-position; Circular connector 12-position
Fire-Wire	400 Mbit/s	CIM, Propulsion	D-Sub 9-position; Circular connector 9-position

Fig. 1: Data rates for different signal bus applications

A MINI-SNAP size 0, 7-position connector was tested for suitability for an application in a fire-wire IEEE 1394-1995 bus.

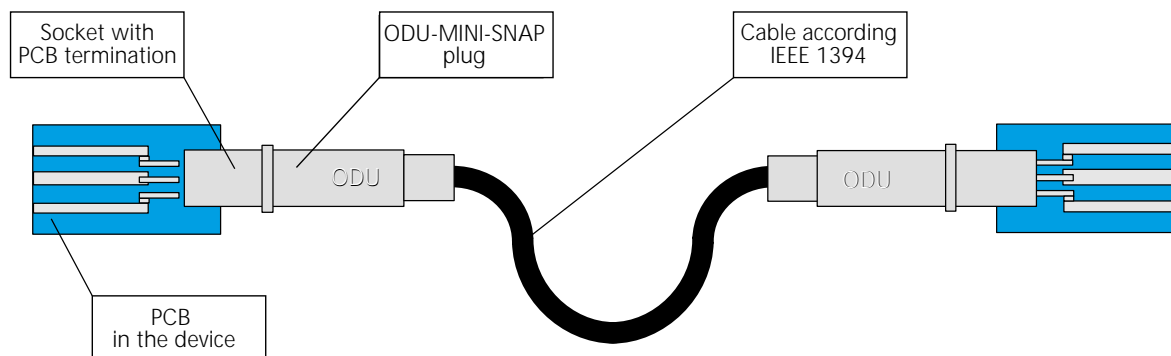

Fig. 2: Test set-up for determination of dynamic system behavior

Result:

In accordance with IEEE 1394-1995 the following parameters were measured:

- impedance
- attenuation
- delay
- Cross Talk

Test results showed that the ODU MINI-SNAP connector size 0, 7-position performed within all nominal values.

The ODU MINI-SNAP connectors appear to be suitable for fire-wire bus applications.

Since the other bus systems have lower performance requirements, it is assumed that the ODU MINI-SNAP connector is also suitable for other bus systems.

Autoclaving of ODU MINI-SNAP Connectors

If required ODU can deliver MINI-SNAP connectors for the following sterilization process: Steam-sterilization with pre-vacuum or gravitation-process. Connectors were tested with autoklave equipment with reference to DIN EN 13 060 at 134° C and 500 cycles.

Sterilization Curve:

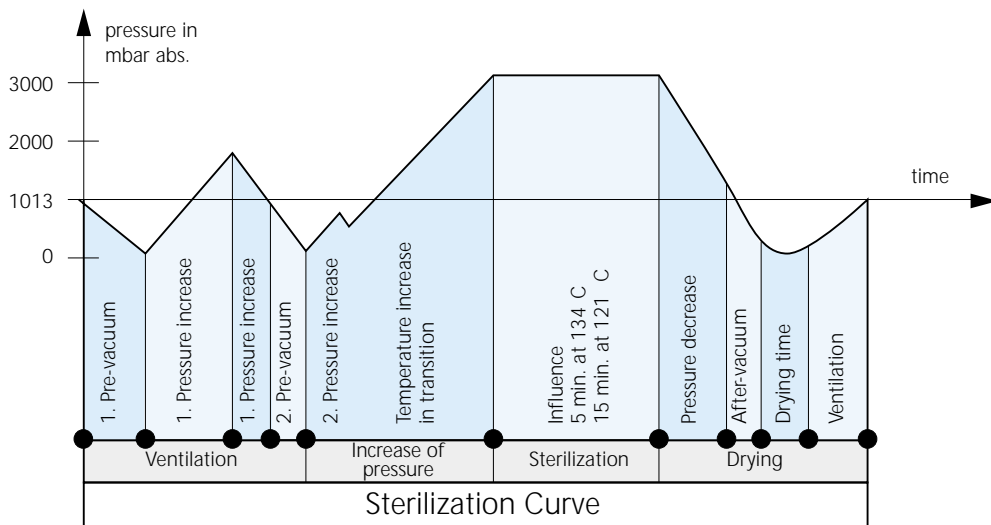

For other sterilization-processes please contact our technical support team.

Quality Management at ODU

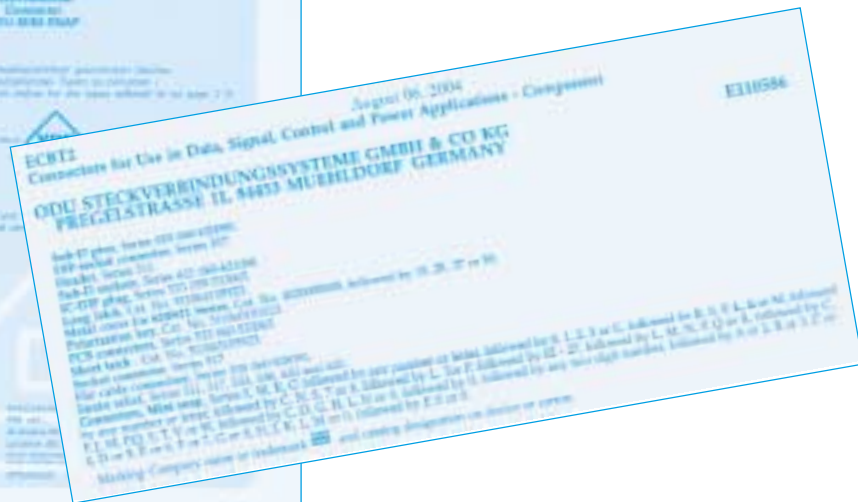

In the scope of quality approval the sizes 0 and 3 have been submitted to environmental and mechanical tests acc. to MIL.

All tests have been passed.

Tests carried out:

Definition	Nach Norm
High Temperature	MIL-STD 810 F / PV 501
Low Temperature	MIL-STD 810 F / PV 502
Temperature Shock	MIL-STD 810 F / PV 503
Humidity	MIL-STD 810 F / PV 507
Salt Fog	MIL-STD 810 F / PV 509 and MIL-STD 1344 A / Methode 1001.1
Shock	MIL-STD 810 F / PV 516
Vibration	MIL-STD 1344 A / Methode 2005.1 / IV
Water Thightness IP 68	IEC 60529

Technical Terms and Definitions

Air Gap

= Shortest distance between two conductive elements through the air.

Autoclavability

(See page 82)

AWG

(See page 76)

Creepage Distance

= The distance measured across the surface of a dielectric between two contacts or a contact and a metal part. The longer the distance, the lesser the risk of damage or tracking. Minimum creepage distances are specified according to the operating voltage and the applicable isolation group.

Crimp Area

= The part of a crimp barrel at which the crimp connection is achieved by pressure deformation or by reshaping the barrel around the conductor.

Crimp Barrel

A hollow part of a contact which accepts one or more conductors and which may be crimped through the application of a crimping tool.

Crimp Connection

= The permanent attachment of a contact to a conductor by pressure deformation or by reshaping the crimp barrel around the conductor so that a good electrical and mechanical connection is established.

(See page 75)

Connector

= A component which terminates conductors for the purpose of providing connection and disconnection to a suitable mating component. Depending on the fastening to a cabinet, panel, rack etc. or a cable, they are classification.

Delivery

Delivery of the connectors usually as components (that means not assembled).

Exception: Solder contacts are factory-installed in the insulation body.

Fixed Connector

= A connector for attachment to a rigid surface (panel).

Free Connector

= A connector for attachment to the free end of a wire or cable. Also called free hanging connector or inline receptacle.

Insertion Or Withdrawal Force

= The force required to fully mate or unmate a set of connectors without the effect of coupling, locking or similar devices. The insertion force is usually greater than the withdrawal force. Also called mating and unmating force.

Insulation Body

= Non-conductive part of a connector, to electrically and mechanically separate live parts and to protect against accidental touch.

Insulation Group

= Classification of connectors according to the operating and working conditions (see page 72 insulation groups according DIN VDE 0110).

Keying

= System of projections and grooves on mating connectors which prevent otherwise identical connectors from being mated. This is useful when several connectors of the same style are used in the same application (see page 26).

Lower Limit Temperature

= The lowest permissible temperature which a connector or a plug-in device is allowed to be operated.

Materials

The contacts are made of CuZn-alloy and gold-plated. The standard housings are made of brass with a matt-chromate surface finish. All other materials and surfaces on special request. (see page 77).

Mating Cycles

= Mechanical operation of connectors and plug-in devices by insertion and withdrawal. One mating cycle comprises one insertion and one withdrawal operation.

Nominal Single Contact Current Load

= Current load, which can load every single contact (see page 74).

Nominal Voltage

Nominal voltage characterizes a component (see page 72).

Operating Temperature of the ODU MINI-SNAP

= Range between upper and lower temperature limits.

- 40 °C to + 120 °C (see page 8)

Print Connection

(see page 75)

Printed Circuit Board

Boards, typically made of epoxy-filled glass fiber fabric, with conductive pattern on one or both sides, or in case of multilayer boards, also imbedded inside the board. They feature metallized holes for soldering wire-mounted components or for the insertion of resilient or rigid press-in pins or instead, pads for attaching components using surface mount technology (SMT).

Reference Current

= The current at which a connector can be operated permanently simultaneously through all contacts without reaching maximum temperature.

Reference Voltage

Normal voltage (VDE 0110) for a connector (see page 72).

Solder Termination

(see page 75 Termination Styles)

Termination techniques

= Methods for connecting a wire to an electro-mechanical component, e.g. solderless connection according to IEC 60352: respectively such as crimp, press-in etc. or solder connections.

Test Voltage

= The voltage the connectors are tested, and are being referred on definite characteristics (see page 72).

Upper Limit Temperature

= highest permissible temperature at which a connector or a plug-in device is allowed to operate. This temperature includes the self-heating and the ambient temperature. At ODU MINI-SNAP + 120 °C (see page 74).

Watertightness

(See page 70 and 71)

Wire

= Wires may be provided with an insulation cover, an electrical shielding. Cables or conductors may consist of one or more wires.

Connectors shown in this catalog are designed to operate at high voltages and high frequencies. Care must be taken to assure that no person can come in contact with live conductors during installation or operation of the connectors.

ODU assured that at the time of print all information in this catalog was correct. ODU reserves the right to change design and performance of any product to meet changing technical developments without prior notice. ODU reserves the right to discontinue any part in this catalog without prior notice and without obligation to continue production after the change.

Please visit us in the Internet

www.odu.de
www.odu-usa.com



On our website you can find a lot of applications. For example: Medical, Measurement and Testing, Telecommunication, Industrial Electronic, etc. .



Additional ODU Push-Pull Series

ODU MINI-SNAP Series L, B, K



The series L, B, K can be mated to the most connectors of LEMO®.

ODU MINI-SNAP Serie S



ODU series S connectors can be mated to the most connectors of LEMO® series S.

ODU MINI-SNAP PC



With this Plastic Push-Pull connector we can meet highest requirements. For example IP 68 or shielded or 100% touch proofed.

ODU MEDI-SNAP



With this Plastic Push-Pull connector we have a mating and mounting compatible product to the REDEL® 1P series.

➔ **There's no licence contract or cooperation with LEMO®.**

In view to the compatibility the declarations on page 9 are valid in the main point.





The Part Number Key

Part Number Key

1	2	3	4	5	6	7	8	9	10	11	12	13	14	15	16	17	18	19
			F			-								-				

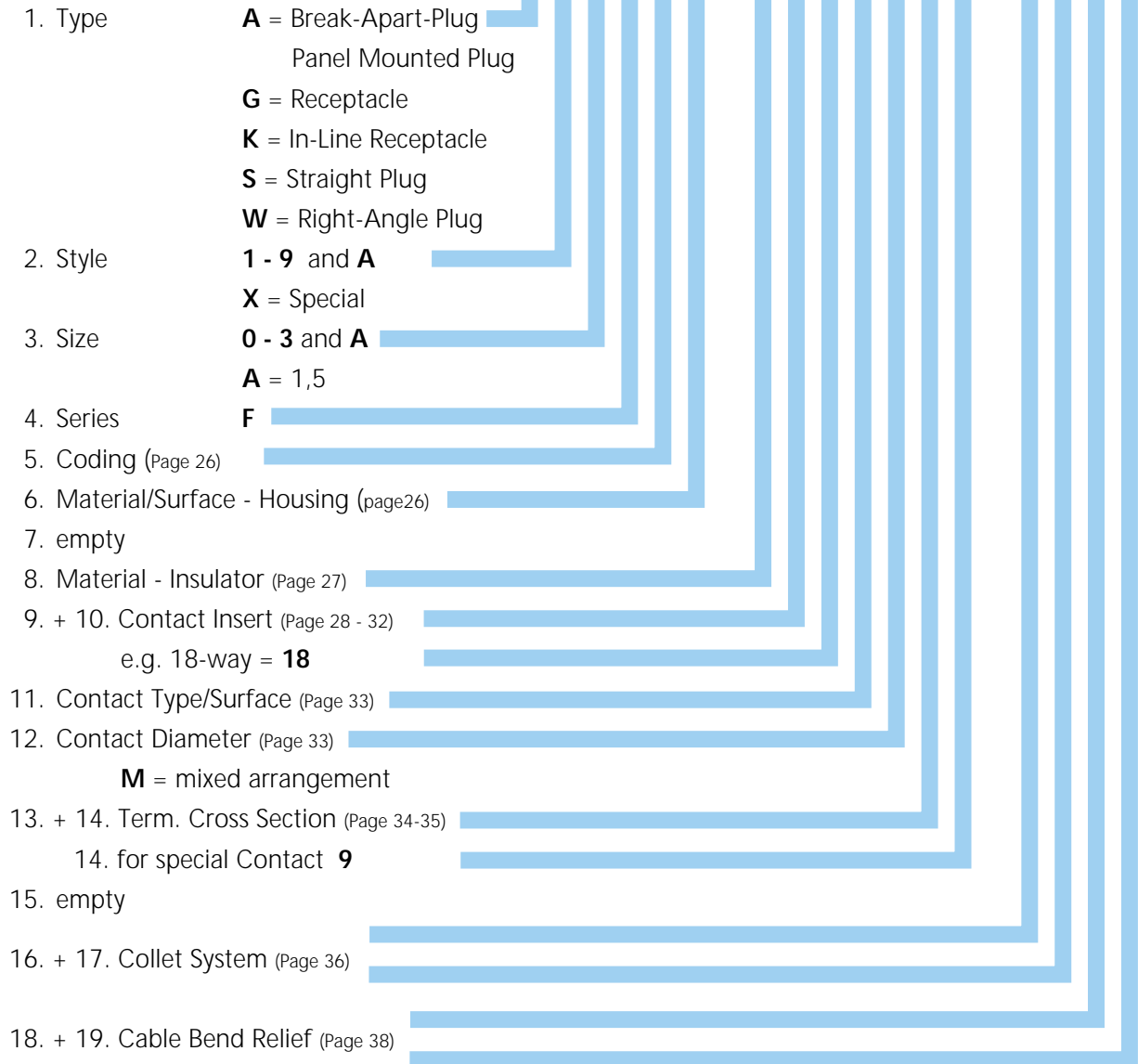

Example:

1	2	3	4	5	6	7	8	9	10	11	12	13	14	15	16	17	18	19
G	5	2	F	1	C	-	T	1	6	L	F	D	0	-	0	0	0	0

Receptacle - Style 5 - Size 2 - Series F - Coding 1 - Brass matt chromate Housing - PBT Insulator - 16pos. - Socket (solder) 0,75 µm Au - Term. Cross Section AWG24/26

1	2	3	4	5	6	7	8	9	10	11	12	13	14	15	16	17	18	19
S	2	2	F	1	C	-	P	1	6	M	F	D	0	-	7	5	E	S

Plug - Style 2 - Size 2 - Series F - Coding 1 - Brass matt chromate Housing - PBT Insulator - 16pos. - Pin (solder) 0,75 µm Au - Term. Cross Section AWG22 - Cable Diameter 7,1-7,5 - Blue Cable Bend Relief - Material Silicone



TELEFAX-INQUIRY ODU MINI-SNAP

Fax-No. **086 31 / 61 56-49** z. Hd. Vertrieb ODU MINI-SNAP
ODU-Steckverbindingssysteme GmbH & Co. KG
 Pregelstraße 11
 D-84453 Mühldorf am Inn

From:

Company:	_____
Name:	_____
Dept.:	_____
Street:	_____
City:	_____
Phone:	_____
Date:	_____

ODU MINI-SNAP Summary of Technical Requirements

1) Connector application : _____

2) Environment : _____

3) Connector Type : Plug Receptacle Inline Receptacle
 90° Plug 90° receptacle

4) Special Version : _____

5) Style : _____

6) Size : 00 0 1 2 3

7) Series : don't care F

8) Keying : _____

9) Number of Positions : _____

10) Termination : solder crimp PCB

11) Cross section of wire : _____ mm² _____ AWG

12) Cable Dia. : _____ mm

13) Bend Sleeve (color) : _____

14) Protection DIN EN 60 529 : IP 50 (Standard) IP 68 (watertight) other _____

15) Operating Temperature : _____ °C max. _____ °C min.

16) Electrical Specs:
Operating Voltage : _____ V AC _____ V DC
Operating Current : Constant _____ A Short-term _____ A, _____ sec.

17) Chemical resistance against : _____

18) Other requirements : _____

19) Autoclavable, +134° C (see page 82) : Yes No

⇨ **Number required** : _____

⇨ **Production Quantity** : _____



ODU's headquarters and factory are located in Mühlendorf, at the river Inn, approximately 50 miles east of Munich, at the foothills



Photo of City Mühlendorf/Inn



Mühlendorf, an idyllic small town with its typical Inn-Salzach architecture.



Steckverbindingssysteme

ODU Steckverbindingssysteme GmbH & Co. KG
Otto Dunkel GmbH

Pregelstraße 11 · D-84453 Mühlendorf/Inn
Telefon +49/86 31/61 56-0
Fax +49/86 31/61 56 49
Internet: <http://www.odu.de>
E-Mail: zentral@odu.de

ODU France
Téléphone: 01.39.35.46.90
Télécopie: 01.39.35.46.91
E-Mail:
jean-nicolas.vikelas@odu.fr

ODU USA Inc.
Tel. 805.484.0540
Fax 805.484.7458
E-Mail:
joe.cisi@odu-usa.com
<http://www.odu-usa.com>

ODU UK Ltd.
Tel. 01509 266 433
Fax 01509 266 777
E-Mail:
sales@odu-uk.co.uk

**ODU (Shanghai)
Int. Trading Co. Ltd**
Tel. +86/21-5834 78 28
Fax +86/21-5834 44 39
E-Mail:
oduchina@odu.com.cn
<http://www.odu-china.com>

ODU Scandinavia AB
Tel. +46/176-1 82 61
Fax +46/176-1 82 62
E-Mail:
peter.biloch@odu.se

**ODU (Shanghai) Connectors
Manufacturing Co. Ltd**
Tel. +86/21-5834 78 28
Fax +86/21-5834 44 39
E-Mail:
markus.bernhuber@odu.com.cn
<http://www.odu-china.com>