

MANUFACTURER  
OF INDUSTRIAL  
PC AND MONITORS



- > COMPACT AND ROBUST
- > LONG TERM DURABILITY
- > COMPATIBLE VGA
- > IP-65 FRONT PANEL

## ELIOS 19S

- > INDUSTRIAL MONITOR IN BOX SLIM
- > LCD TFT DISPLAY 19"
- > RESOLUTION SXGA : 1280 x 1024
- > IP-65 ON FRONT PANEL
- > COMPATIBLE VGA
- > MADE IN FRANCE  
BY **IPO Technologie**
- > INDUSTRIAL POWER SUPPLY
- > THERMALLY REGULATED VENTILATION

### OPTIONAL :

- RESISTANT TOUCH SCREEN
- SEVERAL FIXATION CONFIGURATIONS



Metal box chassis



Cable hider

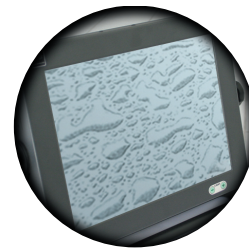

IP-65 on front panel

## MECHANICAL DIMENSIONS

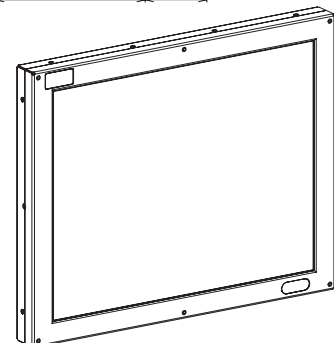
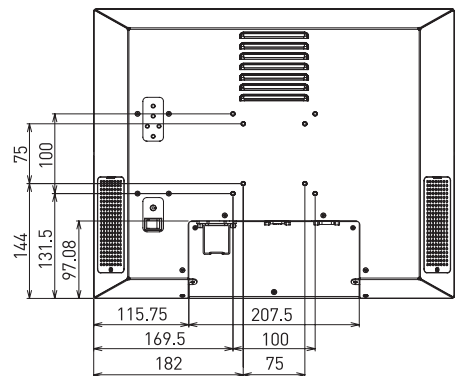
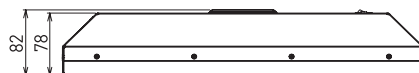
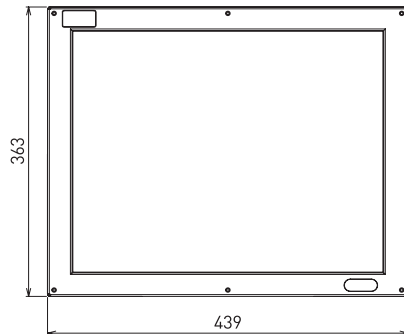



# ELIOS 19S

## SPECIFICATIONS

### > CHASSIS

<b>Without Touch screen</b>	1 mm thick treated metal sheet Anti-reflecting protection on the screen
<b>Touch screen</b>	Optional- see optional touch screen IP-65 on front panel
<b>Color</b>	RAL-7021 black painting RAL-9006 grey painting
<b>Fixation</b>	See option page Fixation VESA 75

### > DISPLAY

<b>Diagonale</b>	19"
<b>Active area</b>	337 x 270 mm
<b>Resolution</b>	1280 x 1024 SXGA
<b>Max.colors</b>	16.7 millions
<b>Pixel pitch</b>	0.264 mm
<b>Brightness</b>	250 cd/m <sup>2</sup>
<b>Contrast</b>	500 : 1
<b>Viewing angle H./V.</b>	150° / 120°

### > I/O CONNECTORS (On back panel)

<b>VGA</b>	SUBD 15 high density male points
<b>Optional touch screen</b>	SUBD 9 female points or USB Mains plug CE22 (AC~)
<b>Anti theft device</b>	keylock Cable hider

### > CONTROLS

<b>On back panel</b>	On/Off switch LED for power
<b>On the side</b>	Screen setup switches (OSD)
<b>On front panel</b>	Brightness control

### > FAN SYSTEM

Cooling fan with ball bearings  
Progressively regulated according to the ambient temperature  
Antidust filter block can be dismantled

### > DIMENSIONS

<b>Width</b>	439 mm
<b>Height</b>	363 mm
<b>Depth</b>	82 mm
<b>Weight</b>	9 kg

### > INDUSTRIAL POWER SUPPLY (cooled by natural convection)

<b>Alternating power version (AC~)</b>	
<b>Input</b>	85 to 265 VAC
<b>Frequency</b>	47 to 63 Hz
<b>Power consumption</b>	65 W max.

### > OPTIONAL TOUCH SCREEN

<b>Technology</b>	High quality Resistant
<b>Light transmission</b>	75 %
<b>Resistance</b>	Main chemicals products Treated against abrasion
<b>Drivers</b>	WINDOWS NT4/2000/XP - LINUX

### > HOMOLOGATIONS

<b>Security</b>	EN60950
<b>EMC</b>	EN55022 EN55024 (EN50081/EN50082) EN61000-4-2 - EN61000-4-4 EN61000-3-3 - EN61000-4-5 ENV50140 (EN61000-4-3) ENV50141 (EN61000-4-6) EN61000-3-2 EN61000-4-11

### > ENVIRONMENTAL

<b>Operation temperature range</b>	0 .... + 50°C
<b>Storage temperature</b>	- 20 .... + 60°C
<b>Humidity without condensation</b>	5 ..... 95 %

### > CABLES

<b>Supplied cable</b>	1 cable VGA of 1.80 m
<b>Version AC~</b>	1 mains cable CE22 of 1.80 m
<b>Version with touch screen</b>	1 cable RS-232 or USB of 1.80 m

### > LIMITED WARRANTY

<b>2 years</b>	Parts and Labor - back to workshop
----------------	------------------------------------

## ORDERING INFORMATION

**ELIOS 19S/AC** Industrial monitor in box chassis Slim  
LCD TFT 19" - power supply 230 VAC

**ELIOS 19SRT/AC** Industrial monitor in box chassis Slim  
LCD TFT 19" - touch screen - RS-232 - power supply 230 VAC

**ELIOS 19SRTUSB/AC** Industrial monitor in box chassis Slim  
LCD TFT 19" - touch screen - USB - power supply 230 VAC

**OPT/PIED 19S** Table base support

**OPT/ARCEAU 19S** Support fixation arceau

For more informations about Accessories & Options, **contact us.**